

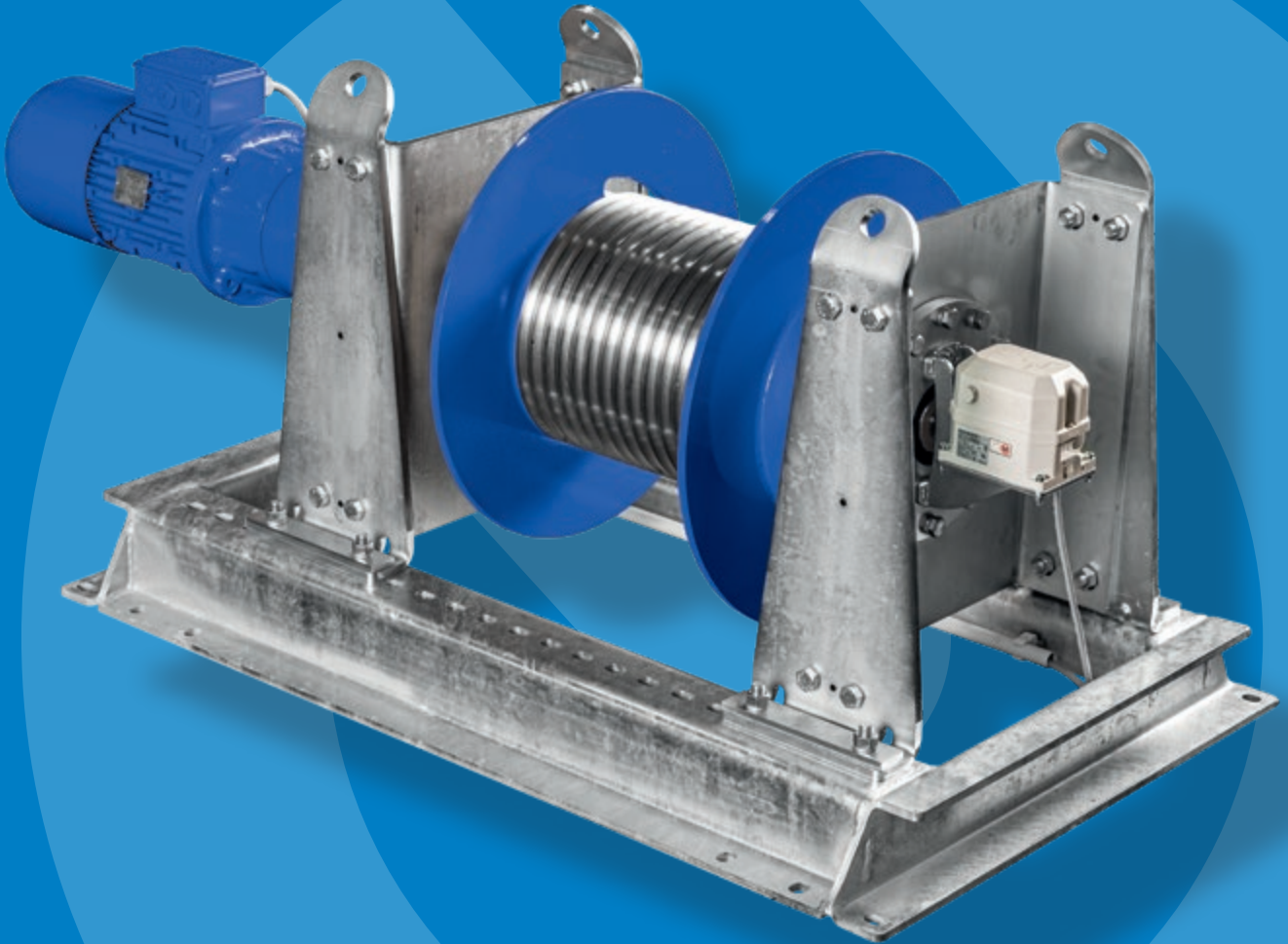

# PLANETA

Hoists and winches since 1861



Rope winch  
program and  
accessories  
No. 26

# Contents

**09**  
12

## **STANDARD ROPE WINCHES**

Electric rope winch PFW-C  
Compact electric rope winch PORTY-II

**13**  
28

## **MODULAR ROPE WINCHES**

Electric rope winch PFW  
Electric rope winch PPW-E  
ATEX Electric rope winch PFW-EX  
Pneumatic rope winch PFW-L  
Pneumatic rope winch PSW-L  
Electric rope winch PKW-E

**29**  
36

## **INDIVIDUAL ROPE WINCHES**

Compact rope winch PCW  
Rope winch PHW

**37**  
45

## **ACCESSORIES & OPTIONS**

PLANETA-Control engineering  
Rope pulley block ULRB  
Rope and lifting equipment  
Wire cable blocks  
Shakles  
Rope winch options

**46**  
49

## **TECHNICAL INFORMATION**

Technical information  
traceparts  
Inquiry form for cable winches

**Note:** PLANETA are constantly striving to increase and further improve the product range. Whilst every effort has been made to ensure the accuracy of the specifications and dimensions included at the time of printing, we are unable to warrant the given information. Designs and specifications are subject to change without notice or obligation. The inclusion of any product does not guarantee the availability of that product in the future. Customers should check both the availability and conformance of the product to any critical parameters at the time of ordering!



# PLANETA

Hoists and winches since 1861

## Quality from tradition

Consistency and innovation are in fact two sides of the same coin, because only a constant willingness to innovate makes sustainable developments possible.

Sustainability, reliability and responsibility are among the fundamental values to which we are committed.

Throughout the company's history, they have been embodied by our employees and their endeavors to make good things even better. a little better.

## Trust is good - but control is better

PLANETA hoists and rope winches are subject to the strictest quality controls and are designed for the toughest operating conditions with high functionality. Exclusively with appropriate overload tested quality products, in compliance with all EN standards, find their way to you.

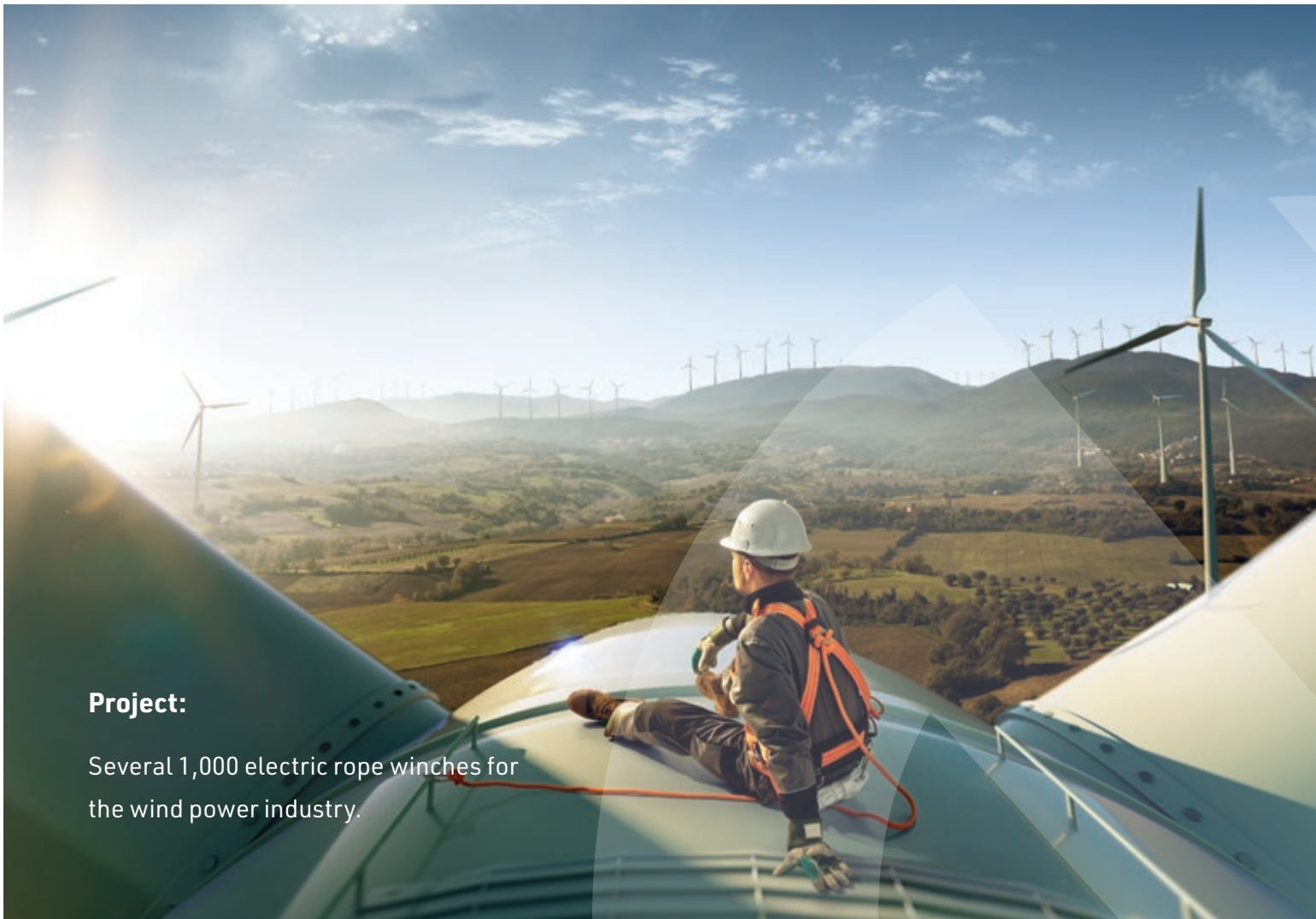

**Project:**

Several 1,000 electric rope winches for the wind power industry.



**Project:**

Personal winch for inspection shaft in highway tunnel.

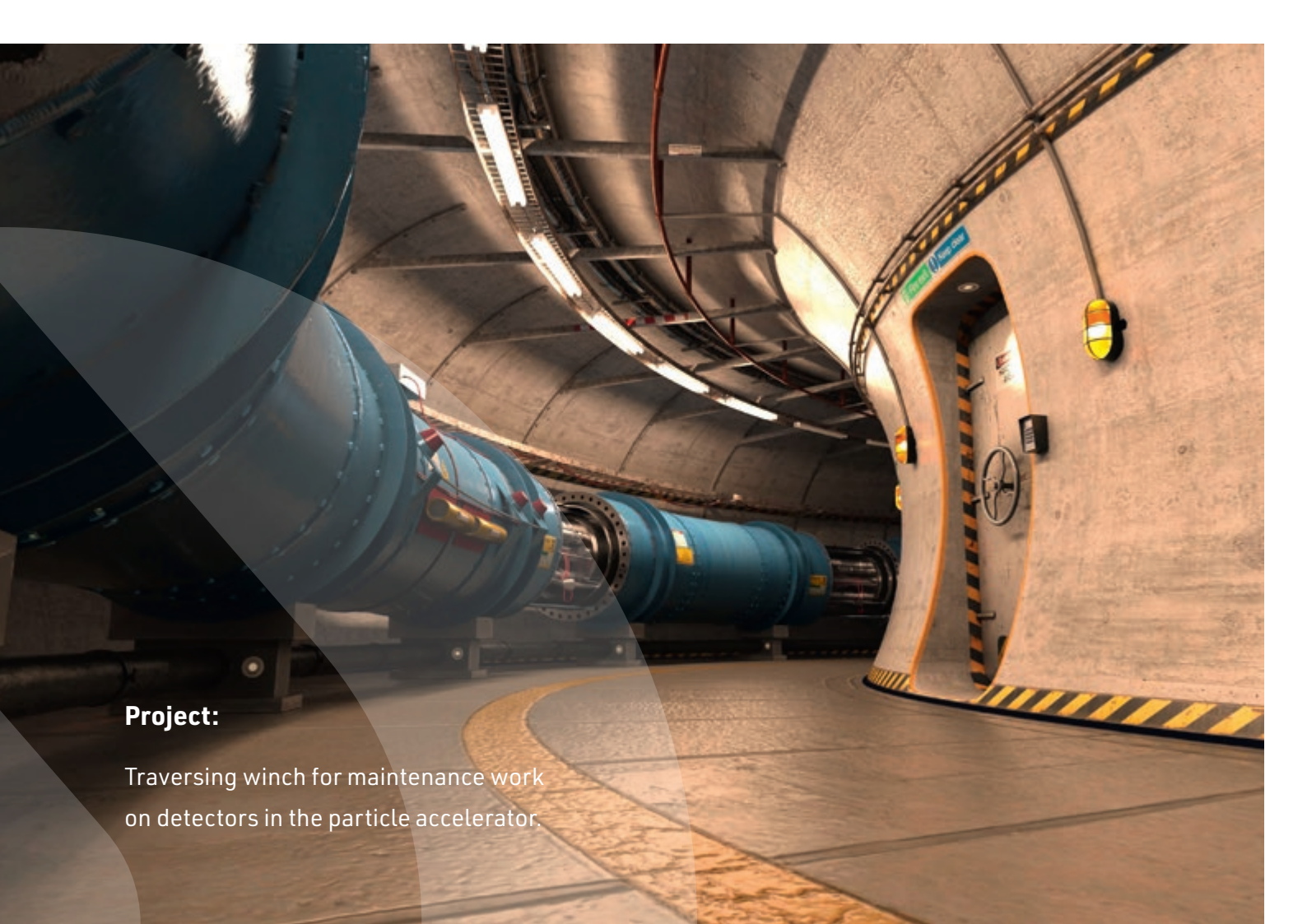

**Project:**

Traversing winch for maintenance work on detectors in the particle accelerator.

## WHAT'S YOUR CHALLENGE?

We have been defying gravity for over 160 years and are proud to be at home all over the world and in many industries. at home in many industries.

As a leading family business for high-quality hoists and cable winches, we have been working at the cutting edge since 1861 and always have our focus on the future.

Our wide product range, consisting of power-driven cable winches, series hoists and accessories, meets the highest quality standards. Whether it's small manual hoists for assembly or large, complex solutions in the field of lifting technology, we offer customized solutions for individual requirements. solutions for individual requirements.

From planning and project management to maintenance, we ensure that our hoists meet your highest safety standards. highest safety standards. Our reliable and efficient products help you to move heavy loads safely and effectively. Let's overcome the limits of gravity together and shape a successful future.

# QUALITY MEANS SAFETY.

Sustainability, reliability and responsibility are values to which we feel particularly committed.

This begins with occupational health and safety during production, through to the certification of all processes as part of the annual TÜV DIN EN ISO 9001:2015 audit or membership of the GKS.



**Quality**  
CERTIFIED



**Industrial safety**  
CERTIFIED



**Environmental protection**  
CERTIFIED





# PARTNERSHIPS THAT STAND FOR QUALITY AND SAFETY.

## Since 2000

Certified according to DIN EN ISO 9000:2001

## Since 2006

Member of the Gütegemeinschaft Kranservice e.V. (GKS)

## Since 2013

Certified according to OHSAS 18001:2007

## Since 2017

Full Member of Lifting Equipment Engineers Association (LEEA)

## Since 2019

Certified according to ISO 9001:2015, ISO 14001:2015 and SCC\*\*:2011



Management  
System  
ISO 9001:2015  
ISO 14001:2015  
SCC\*\*.:2011

[www.tuv.com](http://www.tuv.com)  
ID 9105039001



Full Member

# WHAT TYPES OF ROPE WINCH ARE THERE?

## Mode of application and load bearing capacity

**Pulling winches** are designed to pull loads on a 100 % flat surface. The pulling force is calculated from the mass of the load to be pulled multiplied by the load's rolling resistance. The rolling resistances for the typical applications are around 0,150 for rubber wheels on concrete surfaces and around 0,005 for steel wheels mounted on an anti-friction bearing that are on tracks. If the load is hoisted on an angled surface, the cable winch must be designed as a hoist winch.

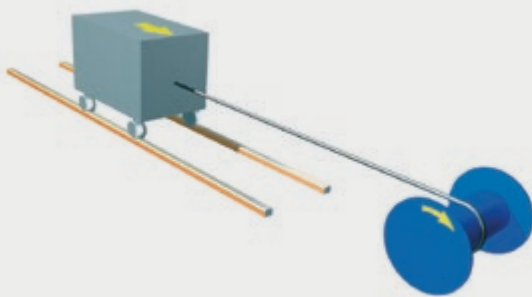

**Hoist winches** must be used if a load is to be raised and held by the cable winch. This applies to hoisting vertically and also to pulling the load along an angled track. Cable winches for hoisting are equipped with spring-loaded brakes on the motor as standard and therefore guarantee that the load will be held securely. In addition, rope winches for hoisting are equipped with higher safety factors than rope winches that are used purely for pulling for example.

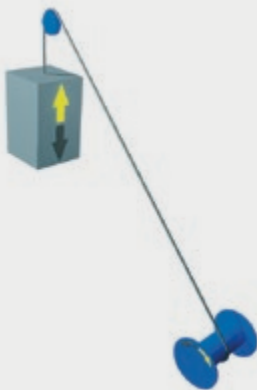

A **traversing winch** can be used to move a load in two directions on a level. You can therefore move a carriage forwards and backwards for example. The cable drum is designed for two cables, is scored and winds in only one layer.

**Capstan winches** are endless winches that do not store the cable on a cable drum but allow the cable to run through "endlessly". A counterforce such as the operator's manual force is multiplied by winding the cable around the capstan head several times. In this way, a much larger pulling force can be achieved from manual force. For example, they stand on deck on a ship and are used to pull cables and ropes in many different directions.

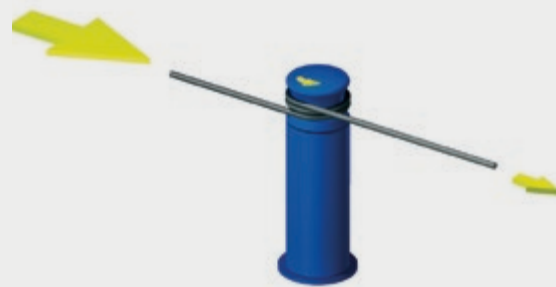

**Traction winches** are endless winches like the capstan winches. They work on the same principle of increasing force due to winding friction. The cable is better fed and protected thanks to their design with two traction sheaves and multiple scores. Traction winches are normally located on carriages that travel forwards and backwards. The pulling cable is stretched between the two ends of the guide rail.

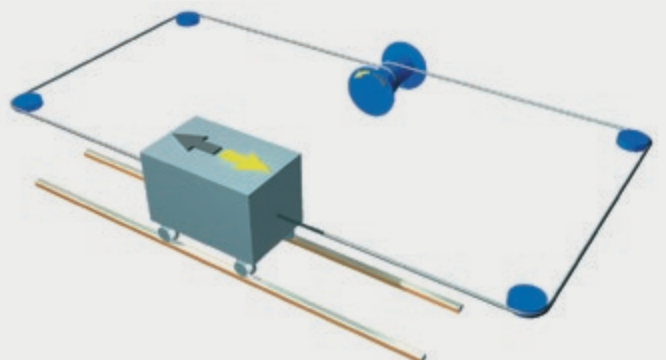

# STANDARD ROPE WINCHES

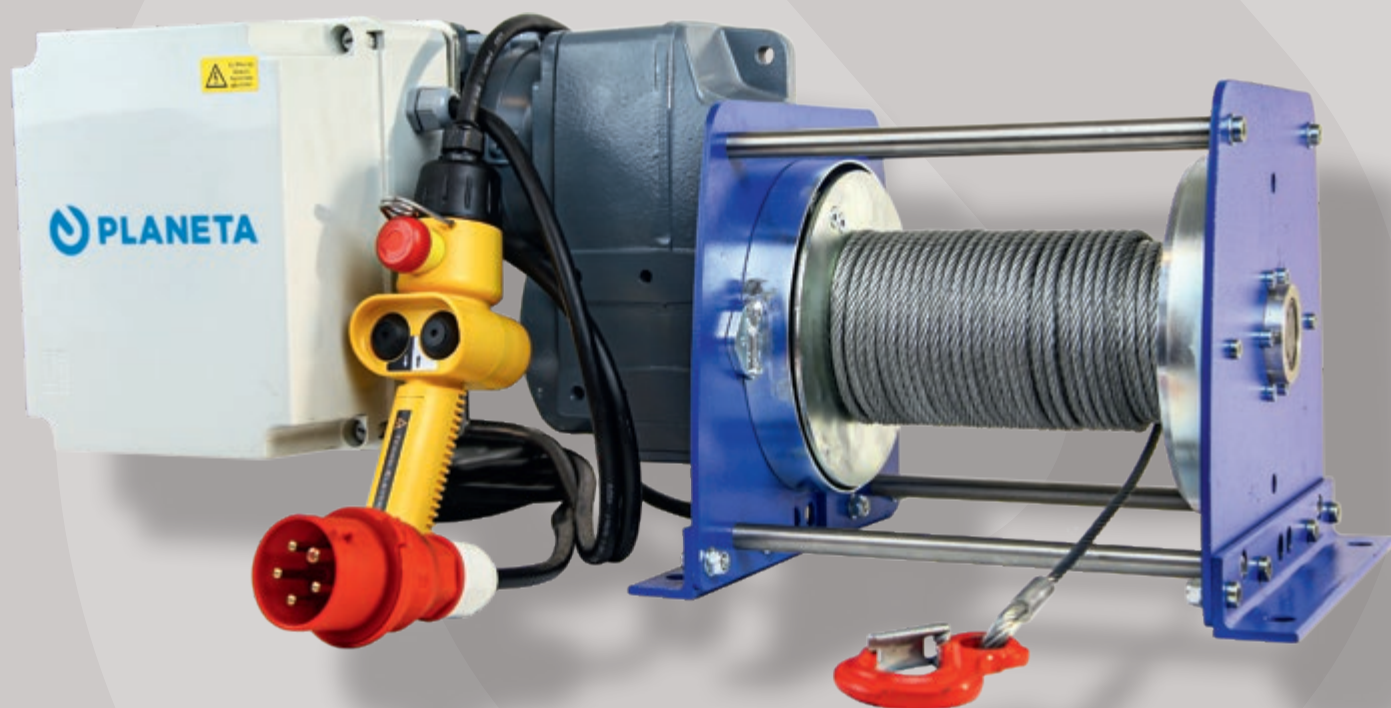



Available at short notice

## ELECTRIC ROPE WINCH | PFW-C

With four load capacities of 250, 500, 1,000 and 2,000 kg, this electric rope winch is one of the most modern devices for pulling, lifting and moving loads. It is approved as a lifting and pulling winch for material transport in accordance with DGUV regulation 54 (D8). Its extensive basic equipment makes it suitable for almost any application. The high duty cycle enables almost uninterrupted use under the toughest conditions.

### Standard equipment:

- Disk brake and spur gear motor
- Grooved drum
- Safety contactor control with low control voltages
- Electric overload protection (over 1,000 kg load capacity)
- Pendant remote control with 3 m cable
- Power supply cable with 3 m cable
- Documentation in German or English
- Test certificate and EC installation declaration

### Technical data:

- Operating voltage 3 Phases / 400 Volt / 50 Hz or 1 Phases / 230 Volt / 50 Hz (alternating current)
- Duty cycle 60% (reference cycle 10 min.)
- Up to 150 starts per hour
- Protection class: IP 55 (jet-water from all sides)
- FEM classification: M3 (1Bm) (e.g. 10 years one hour daily with medium loads)

### Winch control system

The contactor control with a control voltage of 24 VAC combines a lot of safety devices in a compact housing. The use of an extra-low contactor voltage provides protection against dangerous contact voltage in the event of a fault (e.g. damage to the control cable to the control cylinder). Mains monitoring prevents unsafe conditions in the unsafe conditions in the event of a power supply fault.

### Optional equipment:

- Lifting- or pulling rope with security hook
- Operational limit switch
- Protective drum cover
- Drum pressure roller
- CE-Label by full equipment

## info

### Made in Germany.

The PFW range combines a modern design, innovative technology and superlative components, which are produced exclusively in Germany. Prior to shipping, each winch is tested dynamically with 125% of the nominal load and leaves our factory with a 24 month guarantee.

## Basic design

TYPE	PFW-C ...	250	500	990	2000
Lifting capacity in 1st rope layer to max. hoisting-/pulling distance	kg/m	250/7	500/7	990/6	2,000/5
Lifting capacity in 2nd rope layer to max. hoisting-/pulling distance	kg/m	220/16	440/16	865/16	1,750/14
Lifting capacity in 3rd rope layer to max. hoisting-/pulling distance	kg/m	195/27	390/27	770/26	1,550/24
Lifting capacity in 4th rope layer to max. hoisting-/pulling distance	kg/m	175/38	350/39	695/39	1,400/35
Lifting capacity in 5th rope layer to max. hoisting-/pulling distance	kg/m	160/51	320/52	630/51	1,270/48
Lifting capacity in 6th rope layer to max. hoisting-/pulling distance	kg/m	145/65	295/65	580/65	1,165/61
Lifting capacity in 7th rope layer to max. hoisting-/pulling distance	kg/m	135/81	270/81	535/80	1,075/75
Rope diameter	mm	5	6	8	12
Required rope length remaining on drum	m	1.0	1.2	1.6	2.4
Rope speed 1st rope layer	approx. m/min	8	8	8	8 (4)*
Rope speed 2nd rope layer	approx. m/min	9	9	9	9 (4)*
Rope speed 3rd rope layer	approx. m/min	10	10	10	10 (5)*
Rope speed 4th rope layer	approx. m/min	11	11	11	11 (5)*
Rope speed 5th rope layer	approx. m/min	12	12	12	12 (6)*
Rope speed 6th rope layer	approx. m/min	13	13	13	13 (6)*
Rope speed 7th rope layer	approx. m/min	14	14	14	14 (7)*
Motor power	kW	0.37	0.75	1.5	2.6 (1.5)*
PFW-C with 400 V	<b>Order No.</b>	<b>H62100</b>	<b>H62110</b>	<b>H62130</b>	<b>H62150</b>
PFW-C with 230 V (*)	<b>Order No.</b>	<b>H62109</b>	<b>H62119</b>	<b>H62139</b>	<b>H62159</b>
OPTIONS					
Protective drum cover	<b>Order No.</b>	<b>H62840</b>	<b>H62841</b>	<b>H62843</b>	<b>H62845</b>
Operational limit switch	<b>Order No.</b>	<b>H62861</b>	<b>H62861</b>	<b>H62862</b>	<b>H62863</b>
Drum pressure roller	<b>Order No.</b>	<b>H62850</b>	<b>H62851</b>	<b>H62853</b>	<b>H62855</b>
Pulling rope not rotation-resistant with eye hook 8 m**	<b>Order No.</b>	<b>C62101</b>	<b>C62111</b>	<b>C62131</b>	<b>C62151</b>
Additional pulling rope per m	<b>Order No.</b>	<b>C05619</b>	<b>C06619</b>	<b>C08619</b>	<b>C12636</b>
Hoisting rope rotation resistant with swivel hook 8 m**	<b>Order No.</b>	<b>C62102</b>	<b>C62112</b>	<b>C62132</b>	<b>C62152</b>
Additional hoisting rope per m	<b>Order No.</b>	<b>C05177</b>	<b>C06177</b>	<b>C08177</b>	<b>C12177</b>

## Dimensions and weights of the standard designs (Special equipment may vary).

TYPE	PFW-C ...	250	500	990	2000
L1	mm	740	770	860	1,000 (1,050)*
L2	mm	360	360	400	470
B1	mm	270	320	400	550
B2	mm	380	420	470	550
H	mm	315	355	460	620
LTR	mm	200	200	200	200
DTR	mm	65	80	105	155
DFL	mm	155	190	250	370
LB	mm	330	330	360	420
BB1	mm	220	250	350	500
BB2	mm	-	-	220	320
DB	mm	11	12	12	16
Weight without accessories	approx. kg	40	65	110	240 (250)*

\*\* Rope supplied loose as a coil

# Compact electric rope winch



## COMPACT ELECTRIC ROPE WINCH | PORTY-II

Electric rope winch as a hoist winch for material transport



### Standard features:

- Incl. contactor control 3ph / 400V / 50Hz
- Incl. 40 m rope with thimble and eye load hook, ready mounted on winch
- Grooved drum
- Up to 80 m rope length in 7 layers
- Incl. control switch (2-button and emergency stop) on 3 m control cable
- Ambient temperature -10 to +40 °C
- Standard mechanism group acc.FEM 1,001: T4-L1 - M3(1Bm)
- Protection class IP54 (control button IP65)
- Frame components galvanized
- Incl. CEE plug on 3 m power supply cable
- 2 years warranty

### Options:

- Protective drum cover
- Operational limit switch
- Drum pressure roller

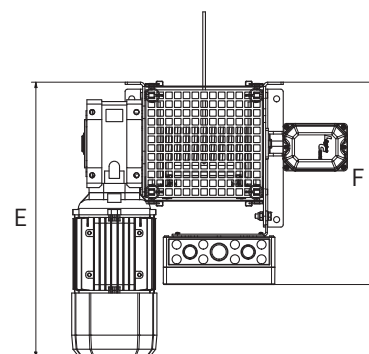
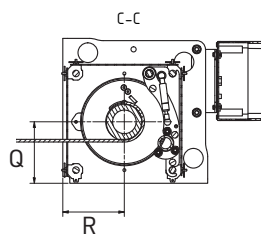
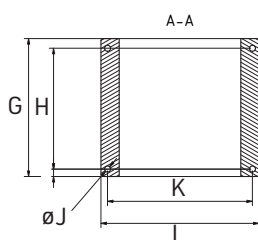
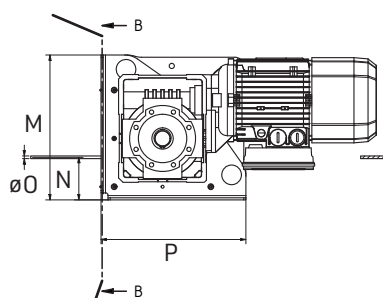
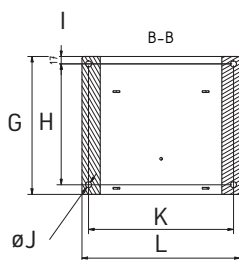
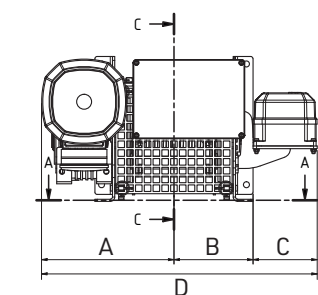

TYPE	PORTY-II	500
Lifting capacity 1st/2nd/3rd/4th/5th/6th/7th rope layer	kg	710/625/555/500/455/420/385
Rope length 1st/2nd/3rd/4th/5th/6th/7th rope layer	m	7/16/27/38/51/65/80
Rope speed 1st/2nd/3rd/4th/5th/6th/7th rope layer	approx. m/min	8/9/10/12/13/14/15
Rope diameter	mm	6
Motor power	kW	1.5
Dimensions (A)	mm	302
B	mm	180
C	mm	146
D	mm	628
E	m	627
F	mm	461
G	mm	314
H	mm	275

TYPE	PORTY-II	500
I	mm	17
J	mm	Ø 13.5
K	mm	330
L	mm	360
M	mm	330
N	mm	97
O	mm	ø6
P	mm	330
Q	mm	140
R	mm	140
DTR drum diameter	mm	80
Weight	kg	68

Order No. H64110

# MODULAR ROPE WINCHES





**Option**  
Grooved drum



**Option**  
Drum protection

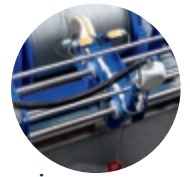

**Option**  
Spooling device

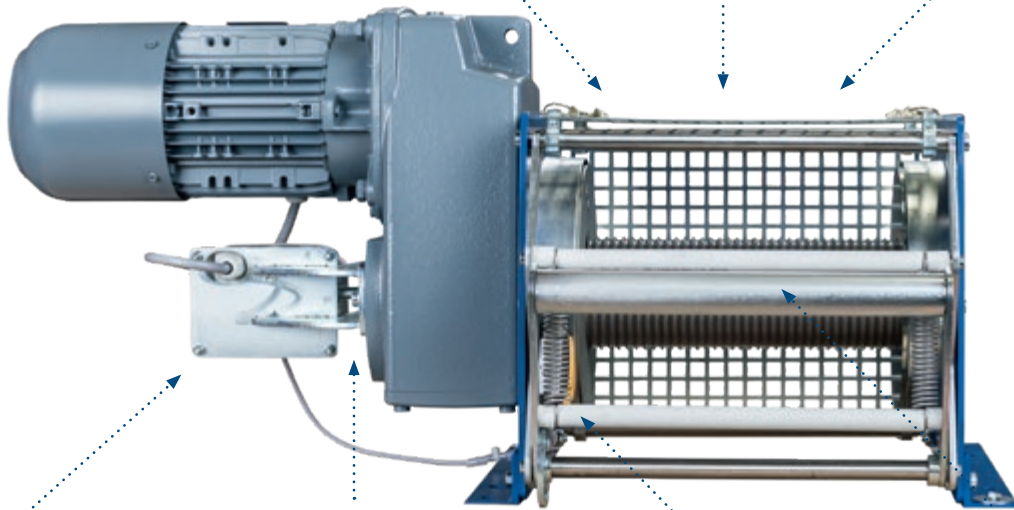

**Option**  
Spindle limit switch



**Option**  
Disengaging clutch



**Option**  
Slack wire switch



**Option**  
Drum pressure roller

## ELECTRIC ROPE WINCH | PFW

With a load bearing capacity from 250 to 3,000 kg this electrical cable winch with its modular construction principle is one of the most modern devices for pulling, lifting and moving loads. With its extensive range of configuration and finishing options it can be adapted to suit almost any installation situation.



The PFW range combines a modern design, innovative technology and superlative components, which are produced exclusively in Germany. Prior to shipping, each winch is tested

dynamically with 125% of the nominal load and leaves our factory with a 24 month guarantee.

### Drive

In standard form the spur gear transmission is equipped with a 3-phase braked motor. The standard operating voltage is 3 Ph / 400 V / 50 Hz. The duty cycle is around 60% thus enabling operation to continue almost without a break in the most difficult of conditions. For unprotected use outdoors the braked motor fulfils protection class IP55.

### Base frame

Torsion-resistant yet flexible, it adapts to almost any surface. We install side guards as standard, which effectively prevent the cable from jumping off. It can be extended if the cable winch is to be attached to a concrete foundation.

### End position switch-off

The spindle limit switch can be mounted on both sides depending on the size and can be extended by a further 4 contacts, external versions or a test button for checking the emergency limit positions. The limit switch can also be retrofitted and is customised to the cable path of the winch.



## Drum guard

The cover prevents unintentional reaching into the rotating rope drum and can prevent injuries. Optionally, the covers can only be removed with tools.

## Slack rope switch

The lowering movement of the cable winch stops automatically as soon as the load settles on the ground or a guided load becomes jammed during lowering and stops. This prevents accidents caused by falling loads.

## Disengaging clutch

The rope drum can only be manually disengaged from the drive and brake for pulling applications where the load is travelling on a horizontal track and does not need to be held by the winch. The rope can then be pulled off by hand.

## Rope drum

With a smooth drum as standard, we can add a grooved drum, extended versions, double drum diameter or double rope outlet on request. rope outlet. Versions in stainless steel, up to 8 rope outlets or for the use of synthetic ropes optional.

## Organised rope winding

It is important to ensure that a fixed deflection is installed at a suitable distance from the centre of the rope

If the rope is still unloaded, the rope pressure roller helps to prevent the rope from moving and loosening on the drum by itself. Wire ropes must be cleaned and lubricated regularly.

## Further versions

Move your winch in an emergency even without a power supply, either just the lowering movement using the hand brake release or lifting and lowering with our self-braking emergency hand crank. Protect your winch from various environmental conditions, e.g. outdoor installation, contact with sea water or air, potentially explosive environments, increased safety if the load is above people or even moving.

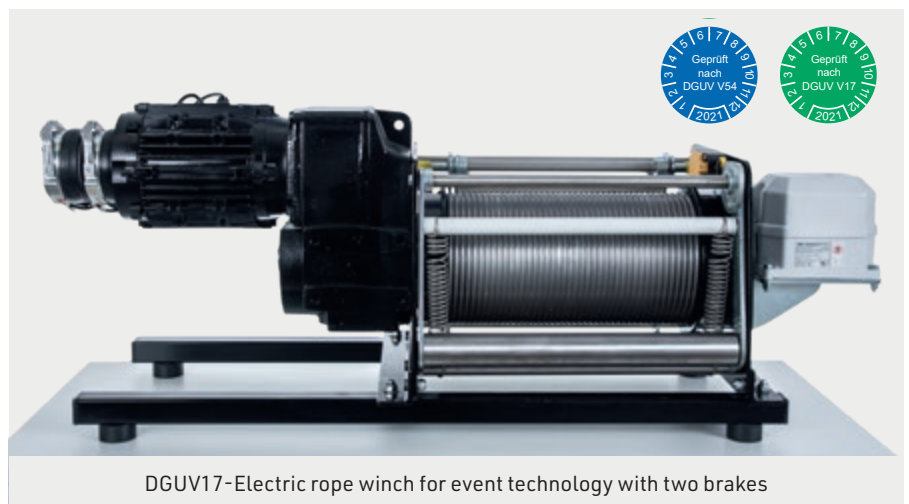

DGUV17-Electric rope winch for event technology with two brakes

drum, over which the rope runs first. In addition, at least 10 % of the specified nominal load must always be applied to the rope as a minimum load to ensure good winding. A grooved drum helps to improve the winding and also ensures smoother running and a shorter distance to the first deflection. Optional spooling devices can reduce this distance even further.



## Basic design

TYPE	PFW-1D	250	500	750	1000	1500	2000	3000
Lifting capacity in 1st rope layer	kg	250	500	750	1,000	1,500	2,000	3,000
Lifting capacity in 5th rope layer	kg	160	320	480	640	950	1,270	1,920
Rope diameter	mm	5	6	7	8	10	12	14
Rope length in 1st rope layer	m	11	11	11	10	10	9	9
Rope length in 5th rope layer	m	75	75	75	75	75	75	75
Expansion every 100 mm extended drum 1st/5th layer	approx. m	4/25	4/25	4/25	4/25	4/25	4/25	4/25
Rope speed 1st rope layer	approx. m/min	8	8	8	8	8	8	8
Rope speed 5th rope layer	approx. m/min	12	12	12	12	12	12	12
Motor power	kW	0.37	0.75	1.1	1.5	2.1	2.6	4
PFW-1D with standard speed	Order No.	<b>H62101</b>	<b>H62111</b>	<b>H62121</b>	<b>H62131</b>	<b>H62141</b>	<b>H62151</b>	<b>H62161</b>
Rope speed 1st rope layer	approx. m/min	4	4	4	4	4	4	4
Rope speed 5th rope layer	approx. m/min	6	6	6	6	6	6	6
Motor power	kW	0.18	0.37	0.55	0.75	1.1	1.5	2.2
PFW-1D with half speed	Order No.	<b>H62104</b>	<b>H62114</b>	<b>H62124</b>	<b>H62134</b>	<b>H62144</b>	<b>H62154</b>	<b>H62164</b>
Rope speed 1st rope layer	approx. m/min	12	12	12	12	12	12	12
Rope speed 5th rope layer	approx. m/min	19	19	19	19	19	19	19
Motor power	kW	0.55	1.1	1.5	2.1	3.2	4	5.5
PFW-1D with fast speed	Order No.	<b>H62103</b>	<b>H62113</b>	<b>H62123</b>	<b>H62133</b>	<b>H62143</b>	<b>H62153</b>	<b>H62163</b>
<b>OPTIONS</b>								
Grooved drum	Order No.	<b>H62800</b>	<b>H62801</b>	<b>H62802</b>	<b>H62803</b>	<b>H62804</b>	<b>H62805</b>	<b>H62806</b>
Longer drum each 100 mm	Order No.	<b>H62810</b>	<b>H62810</b>	<b>H62811</b>	<b>H62811</b>	<b>H62812</b>	<b>H62812</b>	<b>H62813</b>
Second rope outflow	Order No.	<b>H62820</b>	<b>H62821</b>	<b>H62822</b>	<b>H62823</b>	<b>H62824</b>	<b>H62825</b>	<b>H62826</b>
Manual free-wheeling coupling	Order No.	-	<b>H62831</b>	<b>H62832</b>	<b>H62833</b>	<b>H62834</b>	<b>H62835</b>	<b>H62836</b>
Protective drum cover	Order No.	<b>H62840</b>	<b>H62841</b>	<b>H62842</b>	<b>H62843</b>	<b>H62844</b>	<b>H62845</b>	<b>H62846</b>
Drum pressure roller	Order No.	<b>H62850</b>	<b>H62851</b>	<b>H62852</b>	<b>H62853</b>	<b>H62854</b>	<b>H62855</b>	<b>H62856</b>
Emergency limit switch	Order No.	<b>H62861</b>	<b>H62861</b>	<b>H62861</b>	<b>H62862</b>	<b>H62862</b>	<b>H62863</b>	<b>H62863</b>
Operational limit switch	Order No.	<b>H62865</b>	<b>H62865</b>	<b>H62865</b>	<b>H62865</b>	<b>H62865</b>	<b>H62865</b>	<b>H62865</b>
Emergency limit switch with incremental sensor	Order No.	<b>H62866</b>	<b>H62866</b>	<b>H62866</b>	<b>H62866</b>	<b>H62866</b>	<b>H62866</b>	<b>H62866</b>
Slack wire switch	Order No.	<b>H62870</b>	<b>H62871</b>	<b>H62872</b>	<b>H62873</b>	<b>H62874</b>	<b>H62875</b>	<b>H62876</b>
Manual brake release	Order No.	<b>H62881</b>	<b>H62881</b>	<b>H62881</b>	<b>H62882</b>	<b>H62882</b>	<b>H62882</b>	<b>H62883</b>
Manual brake release with crank	Order No.	<b>H62884</b>	<b>H62884</b>	<b>H62884</b>	<b>H62885</b>	<b>H62885</b>	<b>H62885</b>	<b>H62886</b>
Protective paint per <b>ISO12944 C4</b> (high)	Order No.	<b>H62891</b>	<b>H62891</b>	<b>H62892</b>	<b>H62892</b>	<b>H62893</b>	<b>H62893</b>	<b>H62894</b>
Protective paint per <b>ISO12944 C5</b> (very high / marine)	Order No.	<b>H62895</b>	<b>H62895</b>	<b>H62896</b>	<b>H62896</b>	<b>H62897</b>	<b>H62897</b>	<b>H62898</b>

## Dimensions and weights of the standard design (special equipment may vary)

TYPE	PFW-1D	250	500	750	1000	1500	2000	3000
------	--------	-----	-----	-----	------	------	------	------

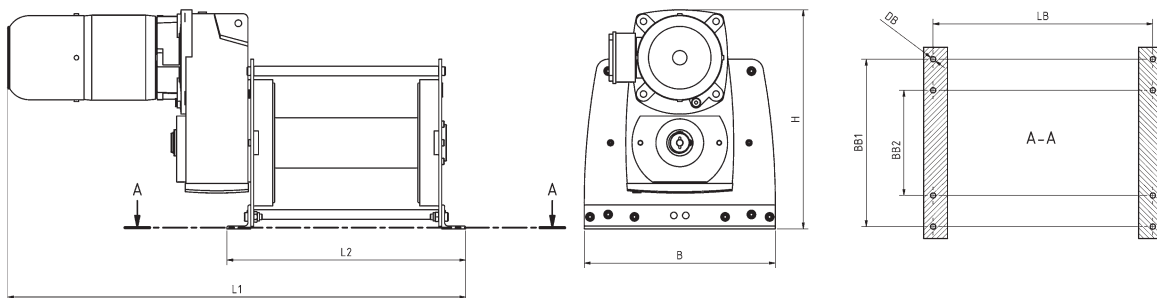

L1	mm	900	910	910	1,020	1,060	1,200	1,300
L2	mm	460	460	460	500	500	570	570
B	mm	270	320	360	400	460	550	620
H	mm	325	360	420	460	550	630	690
LTR	mm	300	300	300	300	300	300	300
DTR	mm	65	80	92	105	130	155	185
DFL	mm	155	190	220	250	310	370	430
LB	mm	430	430	430	460	460	520	520
BB1	mm	220	250	310	350	410	500	560
BB2	mm	-	-	-	220	280	320	380
DB	mm	13.5	13.5	13.5	13.5	13.5	17.5	17.5
Weight without accessories	approx. kg	35	60	75	110	155	240	380

## Double diameter drum, stage & studios

TYPE	PFW-2D	250	500	750	1000	1500	2000	3000
Lifting capacity in 1st rope layer	kg	125	250	375	500	750	1,000	1,500
Rope diameter	mm	5	6	7	8	10	12	14
Rope length in 1st rope layer	m	20	20	20	20	19	18	17
Expansion every 100 mm extended drum 1st layer	approx. m	7	7	7	7	7	7	7
Rope speed 1st rope layer	approx. m/min	15	15	15	15	15	15	15
Motor power	kW	0.37	0.75	1.1	1.5	2.1	2.6	4
PFW-2D with standard speed	<b>Order No.</b>	<b>H62201</b>	<b>H62211</b>	<b>H62221</b>	<b>H62231</b>	<b>H62241</b>	<b>H62251</b>	<b>H62261</b>
Rope speed 1st rope layer	approx. m/min	7	7	8	9	8	7	7
Motor power	kW	0.18	0.37	0.55	0.75	1.1	1.5	2.2
PFW-2D with half speed	<b>Order No.</b>	<b>H62204</b>	<b>H62214</b>	<b>H62224</b>	<b>H62234</b>	<b>H62244</b>	<b>H62254</b>	<b>H62264</b>
Rope speed 1st rope layer	approx. m/min	22	22	22	22	22	22	22
Motor power	kW	0.55	1.1	1.5	2.1	3.2	4	5.5
PFW-2D with fast speed	<b>Order No.</b>	<b>H62203</b>	<b>H62213</b>	<b>H62223</b>	<b>H62233</b>	<b>H62243</b>	<b>H62253</b>	<b>H62263</b>
TYPE	PFW stages and studios	250	500	750	1000	1500	2000	3000
Lifting capacity in 1st rope layer	kg	100	200	300	400	630	900	1,200
Rope diameter	mm	5	6	7	8	10	12	14
Rope length in 1st rope layer	m	19	19	19	19	18	17	16
Expansion every 100 mm extended drum 1st layer	approx. m	7	7	7	7	7	7	7
Rope speed 1st rope layer	approx. m/min	15	15	15	15	15	15	15
Motor power	kW	1.1	1.1	1.1	1.1	2.2	2.2	3.0
	<b>Order No.</b>	<b>H62301</b>	<b>H62311</b>	<b>H62321</b>	<b>H62331</b>	<b>H62341</b>	<b>H62351</b>	<b>H62361</b>
OPTIONS								
Grooved drum	<b>Order No.</b>	incl.	incl.	incl.	incl.	incl.	incl.	incl.
Longer drum	<b>Order No.</b>	<b>H62814</b>	<b>H62814</b>	<b>H62815</b>	<b>H62815</b>	<b>H62816</b>	<b>H62816</b>	<b>H62817</b>
Second rope outflow	<b>Order No.</b>	<b>H62820</b>	<b>H62821</b>	<b>H62822</b>	<b>H62823</b>	<b>H62824</b>	<b>H62825</b>	<b>H62826</b>
Manual free-wheeling coupling (not for stages and studios)	<b>Order No.</b>	-	<b>H62831</b>	<b>H62832</b>	<b>H62833</b>	<b>H62834</b>	<b>H62835</b>	<b>H62836</b>
Protective drum cover	<b>Order No.</b>	<b>H62840</b>	<b>H62841</b>	<b>H62842</b>	<b>H62843</b>	<b>H62844</b>	<b>H62845</b>	<b>H62846</b>
Drum pressure roller	<b>Order No.</b>	<b>H62850</b>	<b>H62851</b>	<b>H62852</b>	<b>H62853</b>	<b>H62854</b>	<b>H62855</b>	<b>H62856</b>
Emergency limit switch	<b>Order No.</b>	<b>H62861</b>	<b>H62861</b>	<b>H62861</b>	<b>H62862</b>	<b>H62862</b>	<b>H62863</b>	<b>H62863</b>
Operational limit switch	<b>Order No.</b>	<b>H62865</b>	<b>H62865</b>	<b>H62865</b>	<b>H62865</b>	<b>H62865</b>	<b>H62865</b>	<b>H62865</b>
Emergency limit switch with incremental sensor	<b>Order No.</b>	<b>H62866</b>	<b>H62866</b>	<b>H62866</b>	<b>H62866</b>	<b>H62866</b>	<b>H62866</b>	<b>H62866</b>
Slack wire switch	<b>Order No.</b>	<b>H62870</b>	<b>H62871</b>	<b>H62872</b>	<b>H62873</b>	<b>H62874</b>	<b>H62875</b>	<b>H62876</b>
Manual brake release	<b>Order No.</b>	<b>H62881</b>	<b>H62881</b>	<b>H62881</b>	<b>H62882</b>	<b>H62882</b>	<b>H62882</b>	<b>H62883</b>
Manual brake release with crank	<b>Order No.</b>	<b>H62884</b>	<b>H62884</b>	<b>H62884</b>	<b>H62885</b>	<b>H62885</b>	<b>H62885</b>	<b>H62886</b>
Protective paint per ISO12944 C4 (high)	<b>Order No.</b>	<b>H62891</b>	<b>H62891</b>	<b>H62892</b>	<b>H62892</b>	<b>H62893</b>	<b>H62893</b>	<b>H62894</b>
Protective paint per ISO12944 C5 (high)	<b>Order No.</b>	<b>H62895</b>	<b>H62895</b>	<b>H62896</b>	<b>H62896</b>	<b>H62897</b>	<b>H62897</b>	<b>H62898</b>

## Dimensions and weights

TYPE	PFW-2D	250	500	750	1000	1500	2000	3000
L1	mm	880	920	920	1,040	1,080	1,200	1,200
L2	mm	460	460	460	500	500	570	570
B	mm	270	320	360	400	460	550	620
H	mm	315	360	420	460	550	630	660
LTR	mm	300	300	300	300	300	300	300
DTR	mm	130	160	185	210	260	310	350
DFL	mm	155	190	220	250	310	370	430
LB	mm	430	430	430	460	460	520	520
BB1	mm	220	250	310	350	410	500	560
BB2	mm	-	-	200	220	280	320	380
DB	mm	13.5	13.5	13.5	13.5	13.5	17.5	17.5
Weight without accessories	approx. kg	40	65	85	120	170	280	425

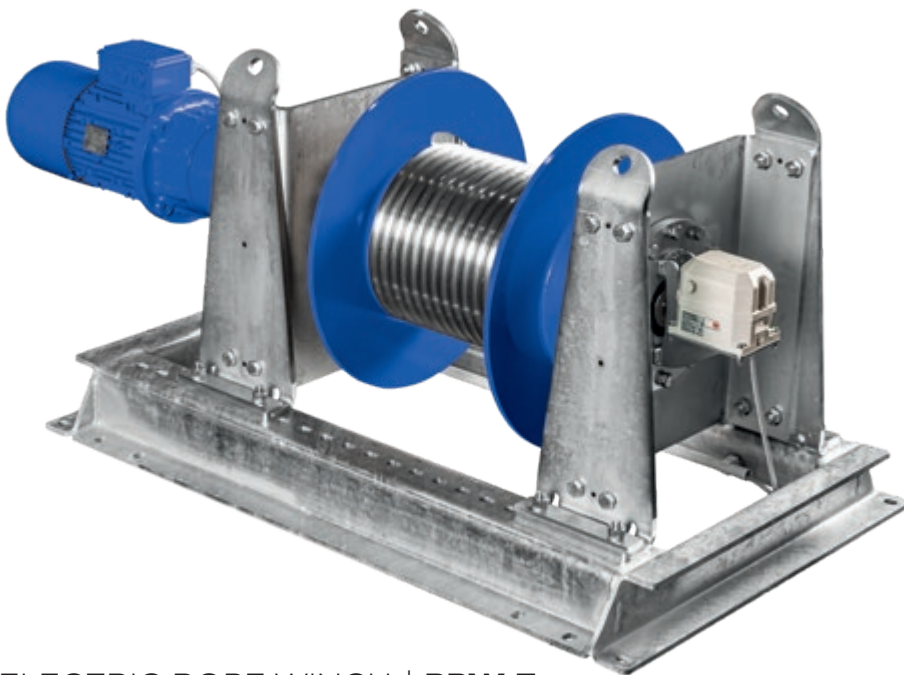

PPW-E  
(with options)



## ELECTRIC ROPE WINCH | PPW-E

The PPW series from PLANETA sets new standards for professional applications in industrial, outdoor, and offshore sectors. These electric rope winches are designed as compact, robust powerhouses and offer impressive performance with a lifting capacity of up to 10 tons and a cable capacity of up to 300 meters.

### Robustness and reliability

Every model in the PPW series is designed for durability. The hot-dip galvanized frame provides effective protection against corrosion, while the maintenance-free design guarantees smooth operation under harsh conditions. With an IP55 protection rating (optionally available up to IP66), the winch is optimally protected against dust and water jets.

### Technical highlights at a glance:

#### Versatile areas of application

Ideal for lifting, pulling, tensioning, and traversing.

#### Precise rope guidance

Equipped with a grooved rope drum as standard for clean winding.

#### Individual control

Available with various fixed or variable speeds.

#### Powerful drives

Standard operation with 3Ph./400V/50Hz; alternative voltages and pneumatic or hydraulic motors are available on request.

#### Customizable classification

Available in FEM groups M3, M4, or M5 depending on the intensity of your application scenario.

### Standard version

- Hot-dip galvanized frame
- Lifting eyes
- Grooved drum
- Standard protection class IP55 and insulation class F
- Standard ambient temperature from -14°F to 104°F
- Standard engine group according to FEM1,001: M3 (1Bm), M4 (1Am), and M5 (2m)
- Standard power connection values: 3-phase / 400 volts / 50 Hz

### Options

- Limit switch
- Screen printing roller
- Slack rope switch
- Multiple rope descents
- Extended drum
- Drum protection cover
- Outdoor and offshore design
- Protection class IP66
- Low/high temperature design
- Various fixed and variable speeds
- Space-saving angular planetary gear

## Basic version PPW-E engine group M3/1Bm

TYPE	PPW-E	04	06	10	15
Lifting capacity in 1st layer	kg	3,600	4,800	6,600	8,800
Lifting capacity in 2nd layer	kg	3,162	4,218	5,800	7,736
Lifting capacity in 3rd layer	kg	2,819	3,762	5,173	6,902
Lifting capacity in 4th layer	kg	2,543	3,395	4,668	6,230
Lifting capacity in 5th layer	kg	2,316	3,093	4,253	5,677
Rope length in 1st layer	m	16	16	16	15
Rope length in 2nd layer	m	40	40	39	38
Rope length in 3rd layer	m	67	67	66	65
Rope length in 4th layer	m	96	96	95	93
Rope length in 5th layer	m	129	129	128	125
Rope speed 1st layer	approx. m/min	6	6	6	7
Rope speed 2nd layer	approx. m/min	7	7	7	8
Rope speed 3rd layer	approx. m/min	8	8	8	9
Rope speed 4th layer	approx. m/min	9	9	9	10
Rope speed 5th layer	approx. m/min	10	10	10	11
Drum/rope diameter	mm	188 / 14	216 / 16	270 / 20	298 / 22
Motor power	kW	4	5.5	7.5	11
PPW-E with standard speed	<b>Order No.</b>	<b>H66121</b>	<b>H66131</b>	<b>H66141</b>	<b>H66151</b>

## Basic version PPW-E engine group M4/1Am

TYPE	PPW-E	04	06	10	15
Lifting capacity in 1st layer	kg	3,200	4,300	6,000	8,000
Lifting capacity in 2nd layer	kg	2,844	3,822	5,333	7,111
Lifting capacity in 3rd layer	kg	2,560	3,440	4,800	6,400
Lifting capacity in 4th layer	kg	2,327	3,127	4,364	5,818
Lifting capacity in 5th layer	kg	2,133	2,867	4,000	5,333
Rope length in 1st layer	m	18	18	18	17
Rope length in 2nd layer	m	44	44	43	42
Rope length in 3rd layer	m	73	73	71	70
Rope length in 4th layer	m	105	104	102	101
Rope length in 5th layer	m	140	139	137	135
Rope speed 1st layer	approx. m/min	7	7	7	8
Rope speed 2nd layer	approx. m/min	8	8	8	9
Rope speed 3rd layer	approx. m/min	9	9	9	10
Rope speed 4th layer	approx. m/min	10	10	10	11
Rope speed 5th layer	approx. m/min	11	11	11	12
Drum/rope diameter	mm	210 / 14	240 / 16	300 / 20	330 / 22
Motor power	kW	4	5.5	7.5	11
PPW-E with standard speed	<b>Order No.</b>	<b>H66221</b>	<b>H66231</b>	<b>H66241</b>	<b>H66251</b>

## Basic version PPW-E engine group M5/2m

TYPE	PPW-E	04	06	10	15
Lifting capacity in 1st layer	kg	2,800	3,800	5,200	6,900
Lifting capacity in 2nd layer	kg	2,522	3,420	4,680	6,210
Lifting capacity in 3rd layer	kg	2,294	3,109	4,255	5,645
Lifting capacity in 4th layer	kg	2,104	2,850	3,900	5,175
Lifting capacity in 5th layer	kg	1,943	2,631	3,600	4,777
Rope length in 1st layer	m	21	20	20	19
Rope length in 2nd layer	m	50	49	49	47
Rope length in 3rd layer	m	82	81	80	78
Rope length in 4th layer	m	117	116	115	113
Rope length in 5th layer	m	155	153	152	150
Rope speed 1st layer	approx. m/min	8	8	8	9
Rope speed 2nd layer	approx. m/min	9	9	9	10
Rope speed 3rd layer	approx. m/min	10	10	10	11
Rope speed 4th layer	approx. m/min	11	11	11	12
Rope speed 5th layer	approx. m/min	12	12	12	13
Drum/rope diameter	mm	240 / 14	272 / 16	340 / 20	374 / 22
Motor power	kW	4	5.5	7.5	11
PPW-E with standard speed	<b>Order No.</b>	<b>H66321</b>	<b>H66331</b>	<b>H66341</b>	<b>H66351</b>

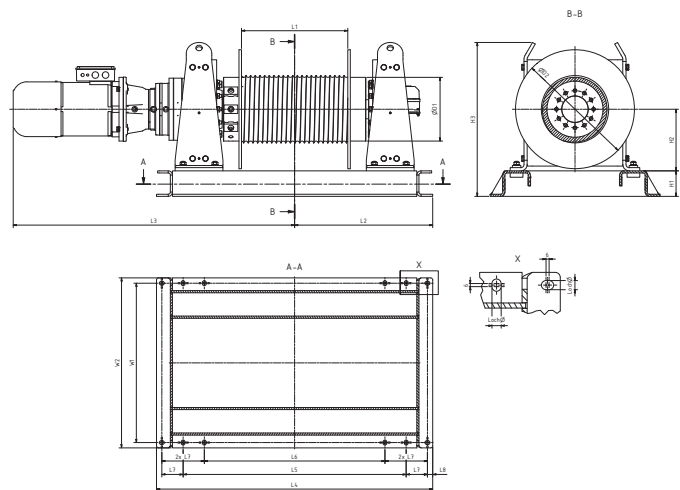

## Dimensions and weights

TYPE	PPW-E	04			06			10			15		
		1Bm	1Am	2m	1Bm	1Am	2m	1Bm	1Am	2m	1Bm	1Am	2m
D1	mm	188	210	240	216	240	272	270	300	340	298	330	374
D2	mm	370	395	425	425	450	480	530	560	600	585	620	660
L1*	mm	500	500	500	500	500	500	500	500	500	500	500	500
L2	mm	600	600	600	625	625	625	650	650	650	650	650	650
L3**	mm	1,155	1,155	1,155	1,290	1,290	1,290	1,325	1,325	1,325	1,510	1,510	1,510
L4	mm	1,200	1,200	1,200	1,250	1,250	1,250	1,300	1,300	1,300	1,300	1,300	1,300
L5	mm	950	950	950	1,000	1,000	1,000	1,050	1,050	1,050	1,050	1,050	1,050
L6	mm	750	750	750	800	800	800	850	850	850	850	850	850
L7	mm	100	100	100	100	100	100	100	100	100	100	100	100
L8	mm	25	25	25	25	25	25	25	25	25	25	25	25
H1	mm	100	100	100	100	100	100	120	120	120	120	120	120
H2	mm	170	170 / 205	205	205	205 / 235	235	255	255 / 290	290	280	280 / 320	320
H3	mm	540	540	540	605	605	605	725	725	725	755	755	755
W1	mm	600	600	600	700	700	700	800	800	800	850	850	850
W2	mm	550	550	550	650	650	650	750	750	750	800	800	800
Hole diameter	∅ mm	14	14	14	18	18	18	18	18	18	22	22	22
Weight without accessories	approx. kg	292	299	313	395	406	427	539	551	563	724	747	759

\*Standard 500 mm, variable in increments of 50 mm \*\* Lengths may vary depending on configuration.

# ATEX Electric rope winch

 II 2 GD de IIB T4 T 135 °C



EX-proof wall-mounted switch



Stainless steel swivel load hook with wire rope.



PFW-EX  
(mit Options)

## ATEX ELECTRIC ROPE WINCH | PFW-EX

With a load bearing capacity from 250 to 3000 kg this electrical rope winch with its modular construction principle is one of the most modern devices for pulling, lifting and moving loads. With its extensive range of configuration and finishing options it can be adapted to suit almost any installation situation. The PFW-EX version is built according to the CE directive 2006/42/EC and European ATEX-guidelines 2014/34/EU. With its special equipment and configuration these winches may be used in areas at risk of explosion.

### Made in Germany

The PFW range combines a modern design, innovative technology and superlative components, which are produced exclusively in Germany. Prior to shipping, each winch is tested dynamically with 125% of the nominal load and leaves our factory with a 24 month guarantee.

### Equipment:

- Electrical control in pressure-resistant casing  
EX II 2 GD de IIB T4 T 135°C
- Standard Protection Classification IP55 with isolation F
- Standard ambient temperature from -10 °C to +40 °C
- Standard mechanism group acc. FEM 1,001: M3 (1Bm)
- Standard supply voltage of 3 PH / 400 Volt / 50 Hz Preisvorteil
- Contactor control available for areas at risk of explosion or standard version for installation in safe areas to combine safe equipment with price advantages
- Pendant remote control and radio remote control available for areas at risk of explosion

### Available options:

- Grooved drum with drum length on customer demand for higher rope storage and better spooling
- Different voltage and frequency
- Adjustable speed with frequency converter
- Free spooling clutch
- Special paintings and higher protection class of electrical equipment for outdoor and offshore applications
- Drum pressure roller
- Multi rope strands or drum divider
- Drum cover
- Limit switches according to ATEX guidelines
- Overload protection
- Special ropes with bronze coated hooks or solid steel version

## Basic design

TYPE	PFW-1D-EX	250	500	750	1000	1500	2000	3000
Lifting capacity in 1st rope layer	kg	250	500	750	1,000	1,500	2,000	3,000
Lifting capacity in 5th rope layer	kg	160	320	480	640	950	1,270	1,920
Rope diameter	mm	5	6	7	8	10	12	14
Rope length in 1st rope layer	m	11	11	11	10	10	9	9
Rope length in 5th rope layer	m	75	75	75	75	75	75	75
Expansion every 100 mm extended drum 1st/5th layer	approx. m	4/25	4/25	4/25	4/25	4/25	4/25	4/25
Rope speed 1st rope layer	approx. m/min	8	8	8	8	8	8	8
Rope speed 5th rope layer	approx. m/min	12	12	12	12	12	12	12
Motor power	kW	0.37	0.75	1.1	1.5	2.1	2.6	4
PFW-1D-EX with standard speed	<b>Order No.</b>	<b>H62401</b>	<b>H62411</b>	<b>H62421</b>	<b>H62431</b>	<b>H62441</b>	<b>H62451</b>	<b>H62461</b>

## Double diameter drum

TYPE	PFW-2D-EX	250	500	750	1000	1500	2000	3000
Lifting capacity in 1st rope layer	kg	125	250	375	500	750	1,000	1,500
Rope diameter	mm	5	6	7	8	10	12	14
Rope length in 1st rope layer	m	20	20	20	20	19	18	17
Expansion every 100 mm extended drum 1st layer	approx. m	7	7	7	7	7	7	7
Rope speed 1st. rope layer	approx. m/min	15	15	15	15	15	15	15
Motor power	kW	0.37	0.75	1.1	1.5	2.1	2.6	4
PFW-2D-EX with standard speed	<b>Order No.</b>	<b>H62501</b>	<b>H62511</b>	<b>H62521</b>	<b>H62531</b>	<b>H62541</b>	<b>H62551</b>	<b>H62561</b>

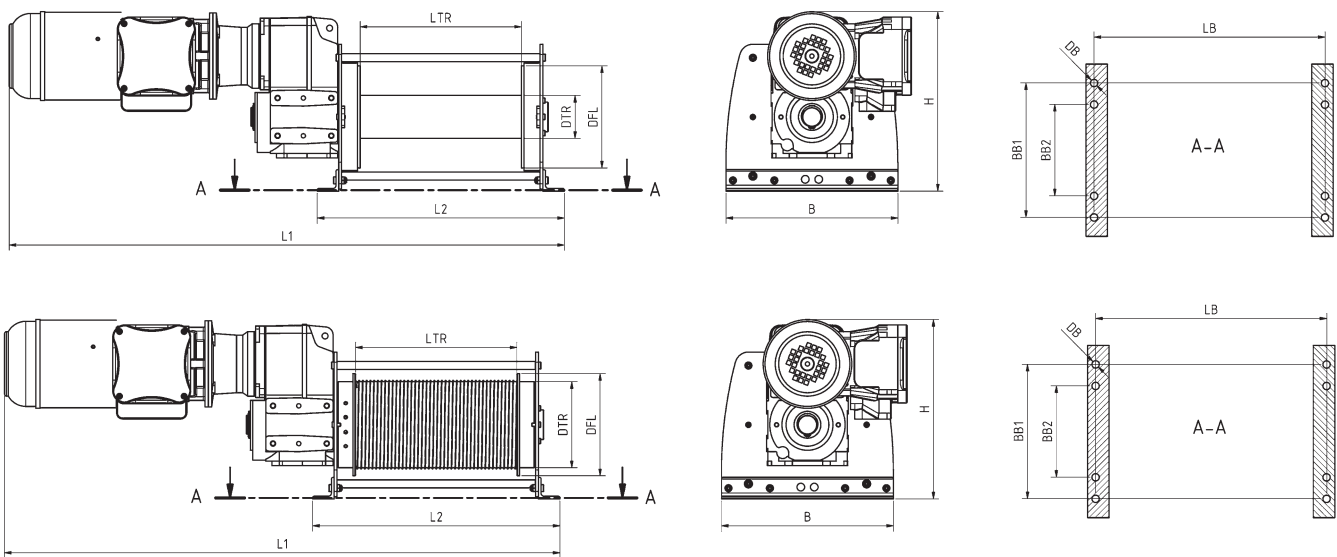

## Dimensions und weights

TYPE	PFW-1D-EX / PFW-2D-EX	250	500	750	1000	1500	2000	3000
L1*	approx. mm	1,000	1,050	1,070	1,160	1,180	1,300	1,350
L2	mm	460	460	460	500	500	570	570
B	mm	270	320	360	400	460	550	620
H	approx. mm	310 / 300	340	420	460	550	630	690 / 660
LTR	mm	300	300	300	300	300	300	300
DTR	mm	65 / 130	80 / 160	92 / 185	105 / 210	130 / 260	155 / 310	185 / 350
DFL	mm	155	190	220	250	310	370	430
LB	mm	430	430	430	460	460	520	520
BB1	mm	220	250	310	350	410	500	560
BB2	mm	-	-	- / 200	220	280	320	380
DB	mm	13.5	13.5	13.5	13.5	13.5	17.5	17.5
Weight without accessories	approx. kg	35 / 40	60 / 65	75 / 85	110 / 120	155 / 170	240 / 280	380 / 425

\*Length can vary according to configuration.

Ex II 2 GD c T4 135 °C

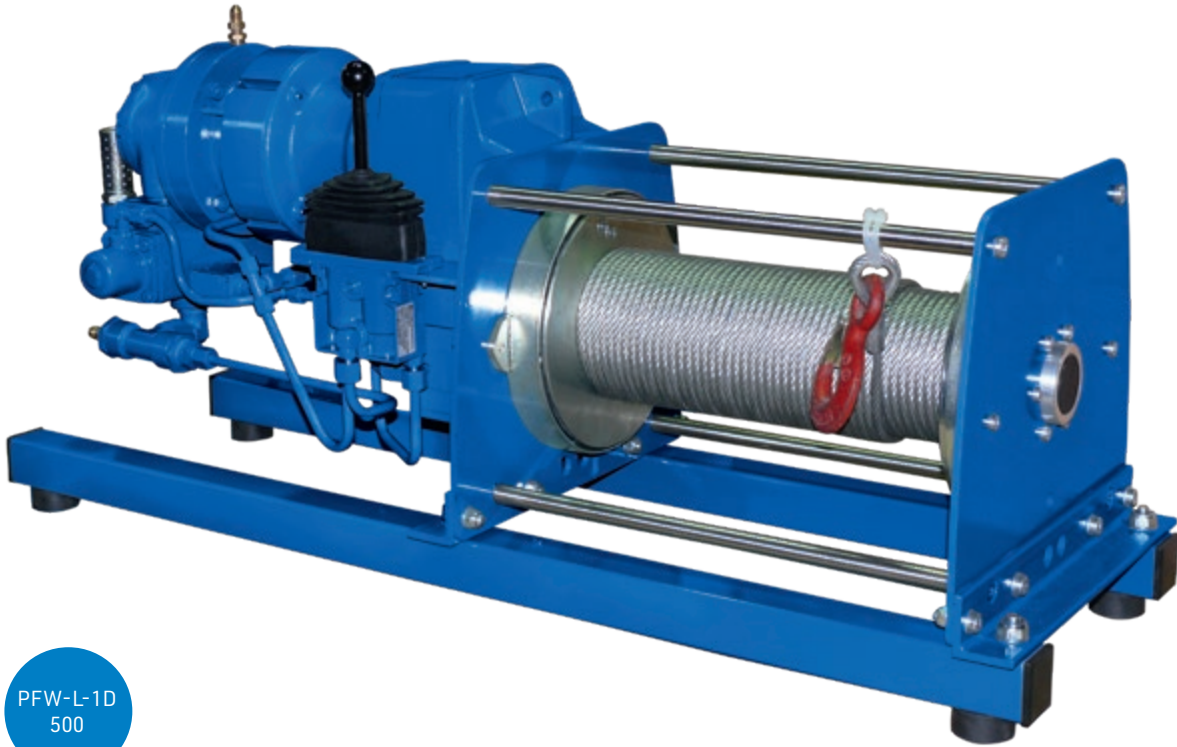

PFW-L-1D  
500



## PNEUMATIC ROPE WINCH | PFW-L

For pneumatic winch applications, demanding a modular and solid design, this range of explosion proof winches provides the solution.

The use of vane type motors and spring applied pneumatic disc brakes ensures trouble free operation and low maintenance requirements.

These winches find their use in general industry, oil and gas exploration and in many places where compact, explosion proof hoisting gear is required.

Because of the modular design of the PFW winch also the pneumatic version can be delivered with advantageous delivery times. Faster rope speeds are available upon request.

### Standard features:

- High efficiency spur gear box
- Rotary vane motor with pneumatic fail-safe disc brake
- Steel drum (not grooved) with rope fixing point at flange
- Two drum supports
- Double layer 2 component coating, colour RAL 5010

### Available options:

- Manual disengaging clutch
- Grooved drum
- Drum pressure roller
- Alternative speeds
- Alternative drum dimensions / split drums / additional rope anchors / etc.
- Drum guard
- Marine / offshore coating systems

- Proportional control valve, local or remote
- Pneumatic limit switch
- Pneumatic slack wire switch

## Basic design

TYPE	PFW-L-1D	500	750	1000	1500	2000	3000
Lifting capacity in 1st rope layer	kg	500	750	1,000	1,500	2,000	3,000
Lifting capacity in 5th rope layer	kg	320	480	640	950	1,270	1,920
Rope diameter	mm	6	7	8	10	12	14
Rope length in 1st rope layer	m	11	11	10	10	9	9
Rope length in 5th rope layer	m	75	75	75	75	75	75
Expansion every 100 mm extended drum 1st/5th layer	approx. m	4/25	4/25	4/25	4/25	4/25	4/25
Rope speed 1st rope layer	approx. m/min	9	10	8	12	8	5
Rope speed 5th rope layer	approx. m/min	14	15	13	18	12	8
Motor power	kW	1.8	2.2	2.2	3.5	3.5	3.5
Air pressure	bar	6	6	6	6	6	6
Air consumption	l/min	45	55	55	80	80	80
PFW-L-1D with standard speed	<b>Order No.</b>	<b>H62611</b>	<b>H62621</b>	<b>H62631</b>	<b>H62641</b>	<b>H62651</b>	<b>H62661</b>

## Double diameter drum

TYPE	PFW-L-2D	500	750	1000	1500	2000	3000
Lifting capacity in 1st rope layer	kg	250	375	500	750	1,000	1,500
Rope diameter	mm	6	7	8	10	12	14
Rope length in 1st rope layer	m	20	20	20	19	18	17
Expansion every 100 mm extended drum 1st layer	approx. m	7	7	7	7	7	7
Rope speed 1st rope layer	approx. m/min	18	19	15	22	15	9
Motor power	kW	1.8	2.2	2.2	3.5	3.5	3.5
Air pressure	bar	6	6	6	6	6	6
Air consumption	l/min	45	55	55	80	80	80
PFW-L-2D with standard speed	<b>Order No.</b>	<b>H62711</b>	<b>H62721</b>	<b>H62731</b>	<b>H62741</b>	<b>H62751</b>	<b>H62761</b>

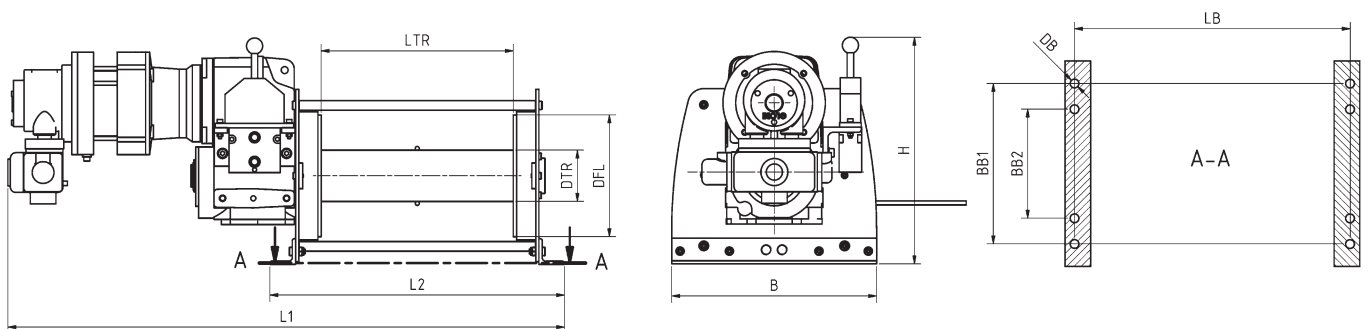

## Dimensions and weights

TYPE	PFW-L-1D/ PFW-L-2D	500	750	1000	1500	2000	3000
L1	approx. mm	890	980	1,050	1,110	1,210	1,275
L2	mm	460	460	500	500	570	570
B	mm	320	360	400	460	550	620
H	approx. mm	330	410	460	540	620	680
LTR	mm	190	220	250	310	370	430
DTR 1D/2D	mm	80/160	92/185	106/210	130/260	155/310	186/350
DFL	mm	190	220	250	310	370	430
LB	mm	430	430	460	460	520	520
BB1	mm	250	310	350	410	500	560
BB2	mm	-	-	220	280	320	380
DB	mm	13.5	13.5	13.5	13.5	17.5	17.5
Weight	approx. kg	50	80	105	140	230	355

Ex II 2 GD c T4 135 °C

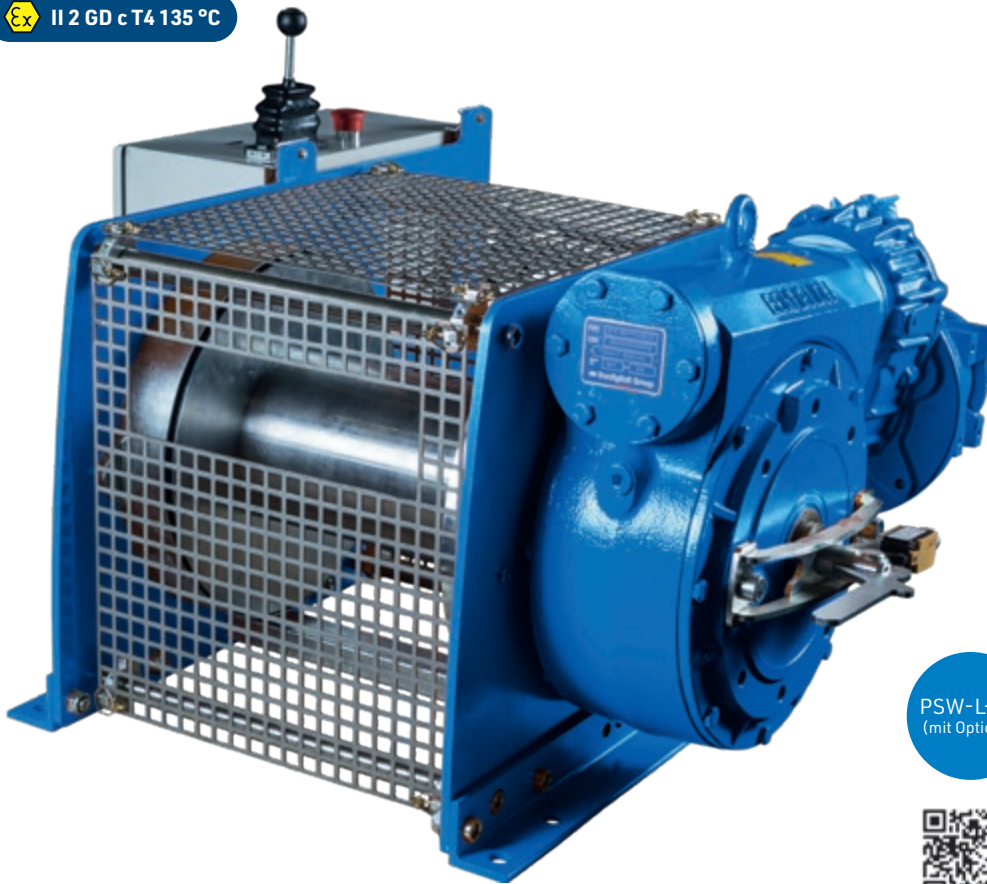

PSW-L-1D  
(mit Options)



## PNEUMATIC ROPE WINCH | PSW-L

For pneumatic winch applications, demanding a modular and solid design, this range of explosion proof winches provides the solution. The use of vane type motors in combination with a self-braking worm gearbox ensures trouble free operation and low maintenance requirements without the need of an additional brake. These winches find their use in general industry, oil and gas exploration and in many places where compact, explosion proof hoisting gear is required. Because of the modular design of the PSW winch it can be delivered with advantageous delivery times. Upon request faster or slower rope speeds are available.

### Standard features

- Self-braking worm gearbox
- Low maintenance vane air motor
- Steel drum (not grooved) with cable fixing point at flange
- Two drum supports
- Double layer 2 component conservation, colour RAL 5010

### Available options

- Manual disengaging clutch
- Grooved drum
- Drum pressure roller
- Alternative speeds
- Alternative drum dimensions / split drums / additional rope anchors / etc.

- Drum guard
- Marine / offshore coating systems
- Proportional control valve, local or remote

***Also available in hydraulic version!***

## Basic design

TYPE	PSW-L-1D	250	500	750	1000	1500	2000
Lifting capacity in 1st rope layer	kg	250	500	750	1,000	1,500	2,000
Lifting capacity in 5th rope layer	kg	160	320	480	640	950	1,270
Rope diameter	mm	11	6	7	8	10	12
Rope length in 1st rope layer	m	75	11	11	10	10	9
Rope length in 5th rope layer	m	75	75	75	75	75	75
Expansion every 100 mm extended drum 1st/5th layer	approx. m	4/25	4/25	4/25	4/25	4/25	4/25
Rope speed 1st rope layer	approx. m/min	8	8	8	8	8	8
Rope speed 5th rope layer	approx. m/min	12	12	12	12	12	12
Air pressure	bar	6	5	6	6.5	6	5
Air consumption	l/min	35	45	80	90	120	190
PSW-L-1D with standard speed	<b>Order No.</b>	<b>H64601</b>	<b>H64611</b>	<b>H64621</b>	<b>H64631</b>	<b>H64641</b>	<b>H64651</b>

## Double diameter drum

TYPE	PSW-L-2D	250	500	750	1000	1500	2000
Lifting capacity in 1st rope layer	kg	125	250	375	500	750	1,000
Rope diameter	mm	5	6	7	8	10	12
Rope length in 1st rope layer	m	20	20	20	20	19	18
Expansion every 100 mm extended drum 1st layer	approx. m	7	7	7	7	7	7
Rope speed 1st rope layer	approx. m/min	15	15	15	15	15	15
Air pressure	bar	6	5	6	6.5	6	5
Air consumption	l/min	35	45	80	90	120	190
PSW-L-2D with standard speed	<b>Order No.</b>	<b>H64701</b>	<b>H64711</b>	<b>H64721</b>	<b>H64731</b>	<b>H64741</b>	<b>H64751</b>

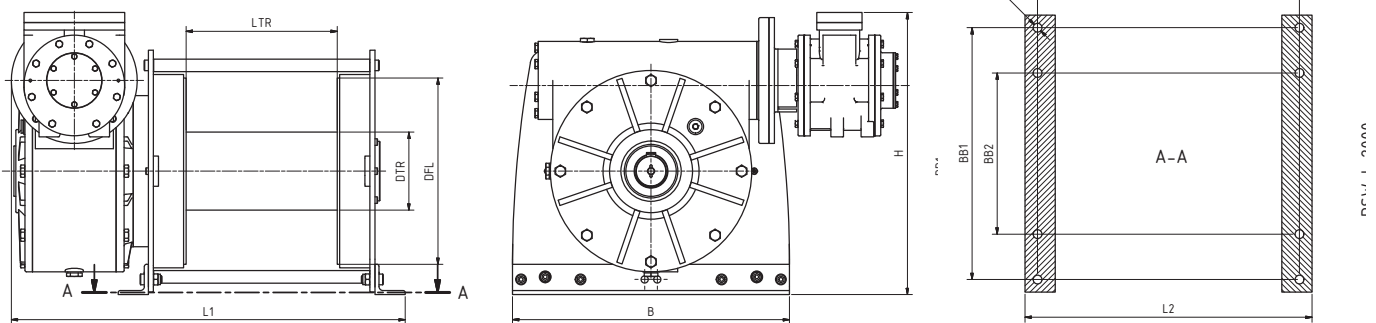

## Dimensions and weights

TYPE	PSW-L-1D/ PSW-L-2D	250	500	750	1000	1500	2000
L1	approx. mm	552	563	624	667	707	782
L2	mm	460	460	460	500	500	570
B	mm	270	320	360	400	460	550
H	approx. mm	234	283	368	410	485	560
LTR	mm	300	300	300	300	300	300
DTR 1D/2D	mm	65/130	80/160	92/185	105/210	130/260	155/310
DFL	mm	155	190	220	250	310	370
LB	mm	430	430	430	460	520	520
BB1	mm	220	250	310	350	410	500
BB2	mm	-	-	-	220	280	320
DB	mm	13.5	13.5	13.5	13.5	13.5	17.5
Weight	approx. kg	35	50	88	120	172	250

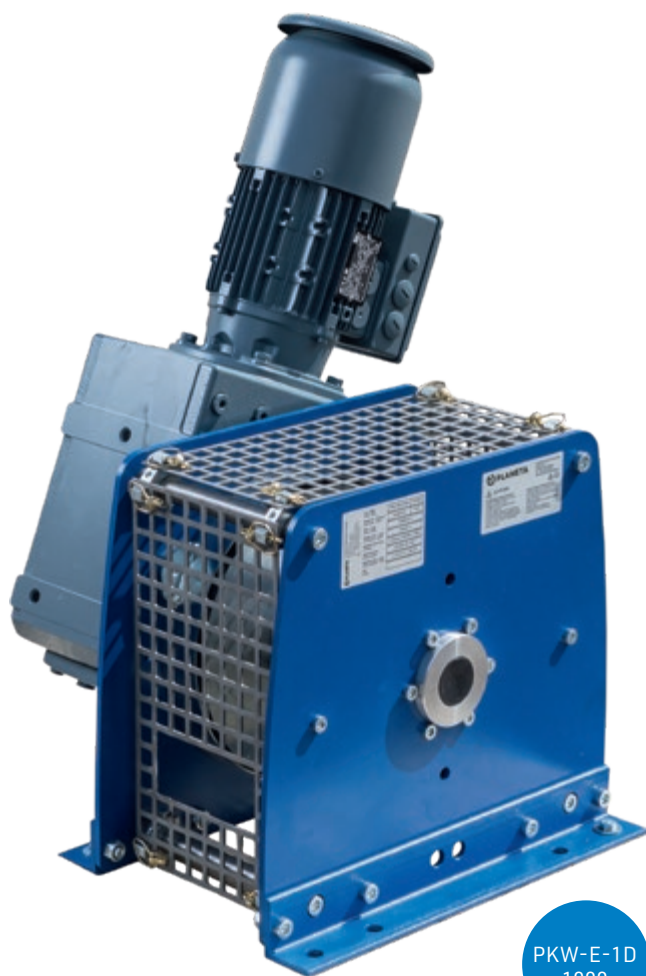

PKW-E-1D  
1000



## ELECTRIC ROPE WINCH | **PKW-E**

As a variation of the PFW-E rope winch, the PKW-E rope winch is equipped with a bevel-helical gear unit. As such, the device is much narrower and can operate in even the tightest of spaces. Due to the close relationship with the PFW rope winch, its performance data and equipment features are identical.

### Standard features:

- Capacity of 250 kg to 3,000 kg
- Bevel-helical gear unit and brake motor
- AC or three-phase motor
- Different speeds and rope capacities
- Protection class IP55 - 66. Duty cycle 60% - 100%
- Low-maintenance with lifetime lubrication
- Mechanism group M3 (1Bm)
- Documentation optionally in German or English
- Log book and EC Declaration of Incorporation

### Options:

- Rope and hook fully installed, multiple rope lead-offs
- Grooved and extended drum, manual free-wheeling coupling
- Drum pressure roller and slack wire switch
- Protective drum cover and special paint finishes
- Further speeds and drum versions
- Versions for ATEX and stages / studios
- Versions for marine / offshore areas

## Basic design

TYPE	PKW-E-1D	250	500	750	1000	1500	2000	3000
Lifting capacity in 1st rope layer	kg	250	500	750	1,000	1,500	2,000	3,000
Lifting capacity in 5th rope layer	kg	160	320	480	640	950	1,270	1,920
Rope diameter	mm	5	6	7	8	10	12	14
Rope length in 1st rope layer	m	11	11	11	10	10	9	9
Rope length in 5th rope layer	m	75	75	75	75	75	75	75
Expansion every 100 mm extended drum 1st/5th layer	approx. m	4/25	4/25	4/25	4/25	4/25	4/25	4/25
Rope speed 1st rope layer	approx. m/min	8	8	8	8	8	8	8
Rope speed 5th rope layer	approx. m/min	12	12	12	12	12	12	12
Motor power	kW	0.37	0.75	1.1	1.5	2.1	2.6	4
PKW-E-1D with standard speed	<b>Order No.</b>	<b>H63101</b>	<b>H63111</b>	<b>H63121</b>	<b>H63131</b>	<b>H63141</b>	<b>H63151</b>	<b>H63161</b>
Rope speed 1st rope layer	approx. m/min	4	4	4	4	4	4	4
Rope speed 5th rope layer	approx. m/min	6	6	6	7	6	7	6
Motor power	kW	0.25	0.37	0.55	0.75	1.1	1.5	2.1
PKW-E-1D with half speed	<b>Order No.</b>	<b>H63104</b>	<b>H63114</b>	<b>H63124</b>	<b>H63134</b>	<b>H63144</b>	<b>H63154</b>	<b>H63164</b>
Rope speed 1st rope layer	approx. m/min	12	12	12	12	12	12	12
Rope speed 5th rope layer	approx. m/min	19	19	19	19	19	19	19
Motor power	kW	0.55	1.1	1.5	2.1	3.2	4	5.5
PKW-E-1D with fast speed	<b>Order No.</b>	<b>H63103</b>	<b>H63113</b>	<b>H63123</b>	<b>H63133</b>	<b>H63143</b>	<b>H63153</b>	<b>H63163</b>

## Double diameter drum

TYPE	PKW-E-2D	250	500	750	1000	1500	2000	3000
Lifting capacity in 1st rope layer	kg	125	250	375	500	750	1,000	1,500
Rope diameter	mm	5	6	7	8	10	12	14
Rope length in 1st rope layer	m	20	20	20	20	19	18	17
Expansion every 100 mm extended drum 1st layer	approx. m	7	7	7	7	7	7	7
Rope speed 1st rope layer	approx. m/min	15	15	15	15	15	15	15
Motor power	kW	0.37	0.75	1.1	1.5	2.1	2.6	4
PKW-E-2D with standard speed	<b>Order No.</b>	<b>H63201</b>	<b>H63211</b>	<b>H63221</b>	<b>H63231</b>	<b>H63241</b>	<b>H63251</b>	<b>H63261</b>
Rope speed 1st rope layer	approx. m/min	8	7	7	8	8	9	7
Motor power	kW	0.18	0.37	0.55	0.75	1.1	1.5	2.2
PKW-E-2D with half speed	<b>Order No.</b>	<b>H63204</b>	<b>H63214</b>	<b>H63224</b>	<b>H63234</b>	<b>H63244</b>	<b>H63254</b>	<b>H63264</b>
Rope speed 1st rope layer	approx. m/min	22	22	22	22	22	22	22
Motor power	kW	0.55	1.1	1.5	2.1	3.2	4	5.5
PKW-E-2D with fast speed	<b>Order No.</b>	<b>H63203</b>	<b>H63213</b>	<b>H63223</b>	<b>H63233</b>	<b>H63243</b>	<b>H63253</b>	<b>H63263</b>

PKW-E-1D

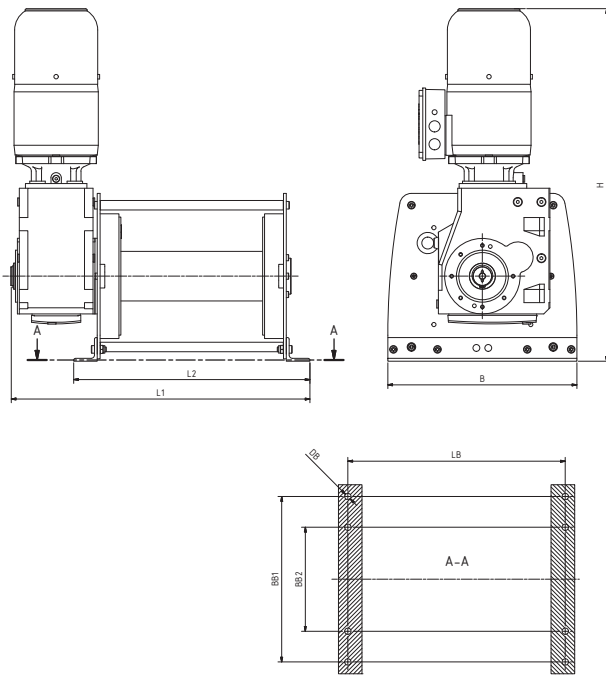

PKW-E-2D

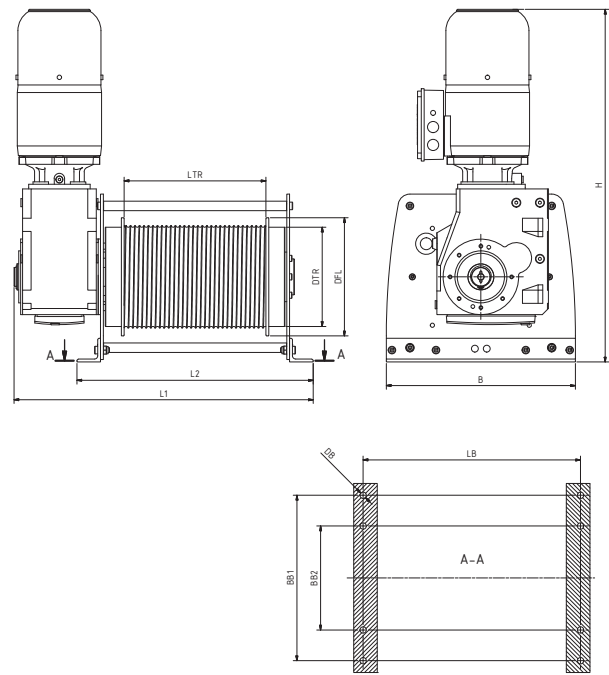

## Dimensions and weights

TYPE	PKW-E-1D/ PKW-E-2D	250	500	750	1000	1500	2000	3000
L1	approx. mm	570	575	580	635	670	770	820
L2	mm	460	460	460	500	500	570	570
B	mm	270	320	360	400	460	550	620
H	approx. mm	530	630	660	750	790	890	890
LTR	mm	300	300	300	300	300	300	300
DTR 1D/2D	mm	65/130	80/160	92/185	105/210	130/260	155/310	185/350
DFL	mm	155	190	220	250	310	370	430
LB	mm	430	430	430	460	460	520	520
BB1	mm	220	250	310	350	410	500	560
BB2	mm	-	-	-	220	280	320	380
DB	mm	13.5	13.5	13.5	13.5	13.5	17.5	17.5
Weight	approx. kg	35/40	55/60	75/85	110/120	200/215	250/290	350/395

## Modular rope winches - Customer solutions

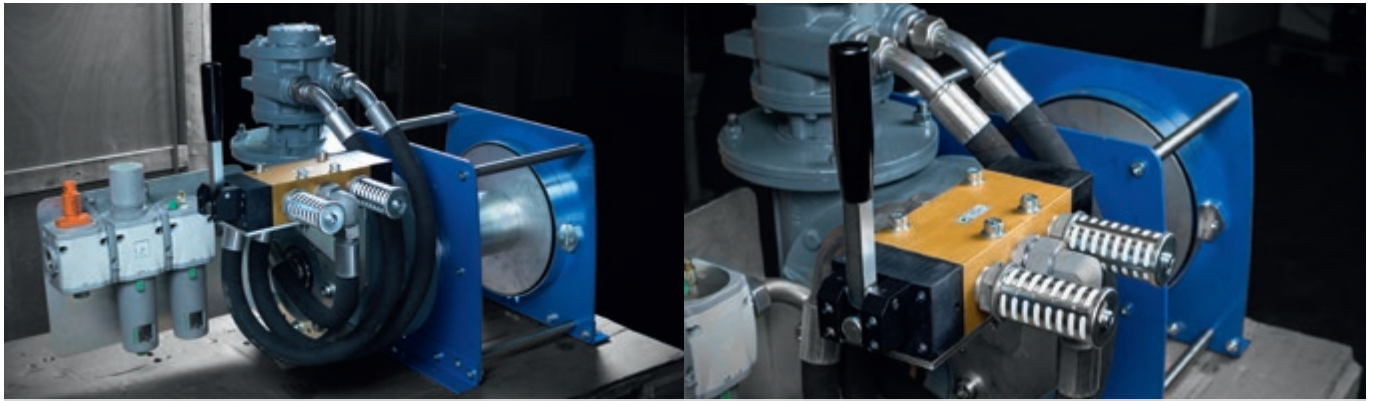

PFW-L 1500 V12 as a pulling winch for the steel industry



PKW-E 1500 V04 as hatch opener inside a cruise ship



Mobile rope winch and spooling device for probing sewers



PKW-E 500 as traversing winches on conveyor belts for container loading

# INDIVIDUAL ROPE WINCHES





PCW  
307-E



PCW with optional equipment

## PLANETARY CRANE WINCHES | PCW

Specially designed for applications where space is at a premium, these compact and lightweight lifting winches are ideally suited for installation on cranes, davits and derricks. The single drum support enables the rope to leave the drum at any angle. The heavy duty planetary drive is partly located within and protected by the drum core. The large drum diameters ensure a healthy drum to cable diameter ratio and sufficient working length despite the short drums.

### Three engine types

The PCW is available with electric, hydraulic or compressed air motor. The load capacities range from 800 kg to 5250 kg. In special cases, special gears are also possible.

### Standard features:

- Heavy duty planetary gearbox
- PCW-E; IP 54 aluminium braked motor 400 VAC/3 phase/50 Hz
- PCW-H; orbit or radial piston type hydraulic motor complete with brake valve
- PCW-LPR; radial piston type air motor complete with hand control valve and mufflers
- Steel drum with cable fixing point at flange
- Single drum support
- Double layer 2 component conservation, colour RAL 5010

### Available options:

- IP 56 TENV cast iron motor for marine applications
- Explosion proof motors
- Protective steel motor cover
- Drum pressure roller
- Alternative speeds
- Alternative supply voltages

- Drum guards
- Marine / offshore coating systems
- Tubular offshore frame construction with lifting eyes

### Available control options:

- Control box IP 55 with pushbuttons and emergency stop
- Control box IP 55 with low voltage IP 65 remote control
- Load limiter (required by CE)
- Frequency inverter for variable speed control
- Wireless radio remote control system
- Limit switches
- Slack wire switches
- Radio / Infra-red remote control



## Electric compact rope winch PCW-E

TYPE	Max. capacity 1st layer kg	Max. capacity top layer kg/layers	Recomm. rope diam. mm	Speed 1st layer m/min.	Speed top layer m/min.	Drum storage 1st layer m	Drum cap. all layers m/layers	Motor power 400 V AC kW	Order No.
PCW 300-E	950	800/4	8	8.5	10	15	70/4	1.5	H50330
PCW 301-E	1,850	1,470/4	11	9	11	10	53/4	3	H50331
PCW 303-E	2,300	1,970/3	12	7	8.5	11	41/3	3	H50332
PCW 305-E	3,350	2,800/3	14	9	11	10	40/3	5.5	H50333
PCW 306-E	4,100	3,500/3	16	7	8.5	15	56/3	5.5	H50334
PCW 307-E	5,250	4,490/3	18	12	14	18	67/3	11	H50335

## Pneumatic compact rope winch PCW-L

TYPE	Max. capacity 1st layer kg	Max. capacity top layer kg/layers	Recomm. rope diam. mm	Speed 1st layer m/min.	Speed top layer m/min.	Drum storage 1st layer m	Drum cap. all layers m/layers	Air pressure bar	Air consumption U/sec.	Order No.
PCW 300-LPR1	800	675/4	8	8	10	15	70/4	7	30	H50342
PCW 300-LPR2	950	800/4	8	18	21	15	70/4	7	90	H50343
PCW 301-LPR2	1,850	1,470/3	11	9	11	10	53/3	7	90	H50344
PCW 303-LPR2	2,300	1,970/3	12	7	8	11	41/3	7	90	H50345
PCW 303-LPR3	2,300	1,970/3	12	15	18	11	41/3	7	150	H50346
PCW 305-LPR3	3,350	2,800/3	14	10	12	10	40/3	7	150	H50347
PCW 306-LPR4	4,100	3,500/3	16	15	18	15	56/3	7	225	H50348
PCW 307-LPR4	5,250	4,490/3	18	12	14	18	67/3	7	240	H50349

## Hydraulic compact rope winch PCW-H

TYPE	Max. capacity 1st layer kg	Max. capacity top layer kg/layers	Recomm. rope diam. mm	Speed 1st layer m/min.	Speed top layer m/min.	Drum storage 1st layer m	Drum cap. all layers m/layers	Air pressure bar	Flow in U/min.	Order No.
PCW 300-H	950	800/4	8	30	35	15	70/4	140	35	H50336
PCW 301-H	1,850	1,470/4	11	20	25	10	53/4	130	55	H50337
PCW 303-H	2,300	1,970/3	12	15	17	11	41/3	130	50	H50338
PCW 305-H	3,350	2,800/3	14	13	16	10	40/3	135	60	H50339
PCW 306-H	4,100	3,500/3	16	13	15	15	56/3	140	70	H50340
PCW 307-H	5,250	4,490/3	18	13	15	18	67/3	170	70	H50341

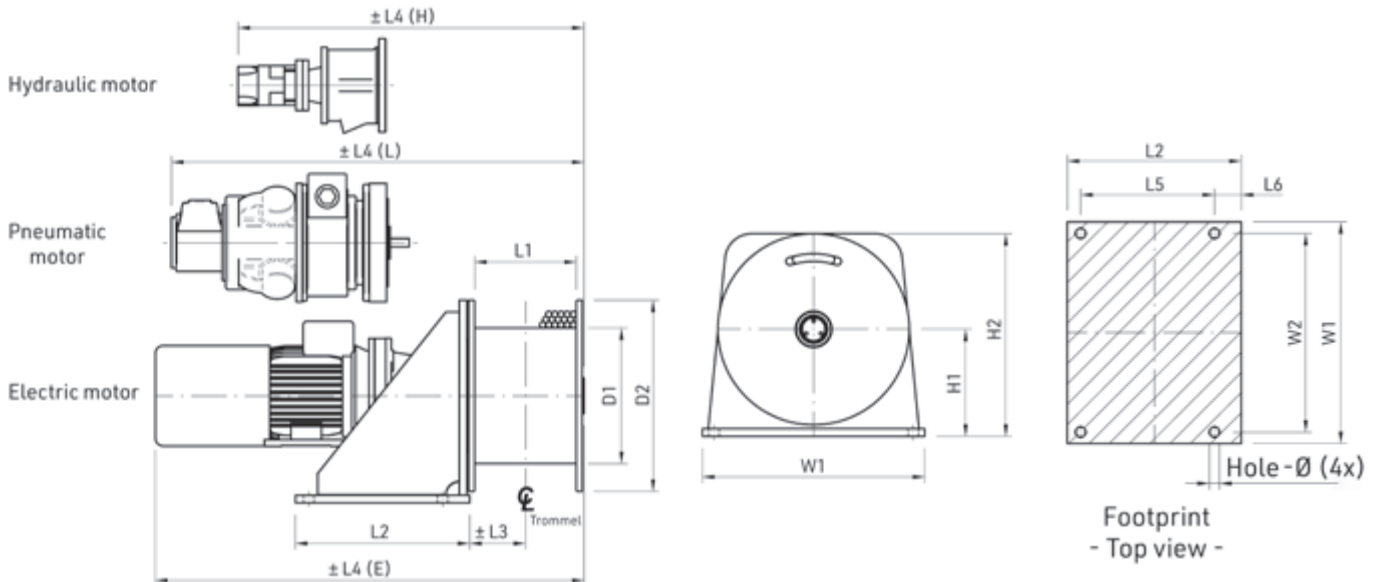

TYPE	Weight kg	Dimensions (mm)														
		D1	D2	L1	L2	L3	L4(E)	L4(H)	L4(L)	L5	L6	H1	H2	W1	W2	Hole-Ø
PCW 300	125	244	380	176	310	93	736	520	765	240	44	215	405	440	400	18
PCW 301	130	244	380	176	310	93	796	558	785	240	44	215	405	440	400	18
PCW 303	175	272	410	191	350	106	818	595	905	275	50	235	440	500	450	22
PCW 305	240	272	410	210	350	116	1,030	625	950	275	50	235	440	500	450	22
PCW 306	330	355	500	266	455	146	1,100	780	1,110	350	70	285	535	580	520	27
PCW 307	590	406	625	310	510	175	1,313	885	1,215	400	75	348	660	750	680	27

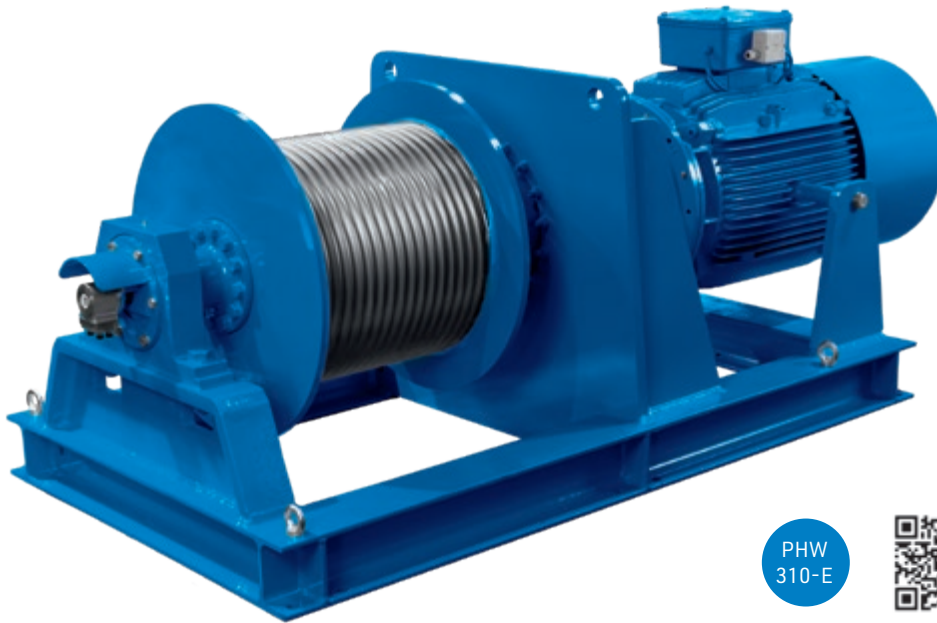

PHW  
310-E



## ROPE WINCH | PHW

The standard build PHW type winch provides the basis of the solution to many pulling and lifting winch applications. The winch is constructed in the conventional manner with motor, gearbox and drum in line. When it comes to the need of a shorter design the PHW winch is available with an angular gearbox.

The choice of the rope complies with the pulling force in the 5th rope layer. The drum is built according to classification 1Am. The drum diameter is at least 16-times bigger than the diameter of the indicated rope diameter. Although the name of this winch indicates different, these winches are very suitable to fit to your specific winch application and can be equipped with different drums, other gearboxes or motors. Many options can be offered on these highly versatile winches. The standard version comes without a rope and control.

### Standard winch features:

- Heavy duty planetary gearbox
- PHW-E; IP 54 aluminium braked motor 400 VAC/3 phase/50 Hz
- PHW-H; orbit or radial piston type hydraulic motor complete with brake valve
- PHW-LPR; radial piston type air motor complete with hand control valve and mufflers
- PHW-LG; gear type air motor complete with hand or remote control valve and mufflers
- Steel drum with cable fixing point at flange
- Two drum supports
- Double layer 2 component conversation, colour RAL 5010

### Available winch options:

- IP 56 TENV cast iron motor for marine applications
- Alternative drum dimensions / split drums / additional rope anchors /etc.
- Explosion proof motors
- Protective steel motor cover
- Drum pressure roller, spooling gears, grooved drums

- Band brakes (manual or failsafe automatic)
- Manual disengaging clutch
- Alternative speeds
- Alternative supply voltages
- Drum guards
- Manual emergency crank
- Slip ring mounting
- Warping head
- Angular gear

### Available control options:

- Control box IP 55 with pushbuttons and emergency stop
- Control box IP 55 with low voltage IP 65 remote control
- Load limiter (required by CE for applications exceeding 1,000 kg W.L.L.)
- Frequency inverter for variable speed control
- Wireless radio remote control systems
- Limit switches (electric, pneumatic)
- Slack wire switches (electric, pneumatic)
- Proportional local or remote control valve (pneumatic or hydraulic)
- Motor overheating protection

## Electric rope winch PHW-E

TYPE	Max. lifting capacity 1st rope layer kg	Max. lifting capacity 5th rope layer kg	Recomm. rope diameter mm	Rope speed 1st rope layer m/min	Rope speed 5th rope layer m/min	Rope length in 1st rope layer m	Rope length in 5th rope layer m	Motor power kW	Order No.
PHW 300-E	1,250	875	9	8.5	12.5	24	155	2.2	H50091
PHW 301-E	2,000	1,400	11	8.5	12.5	24	155	3	H50092
PHW 304-E	3,000	2,100	14	8.5	12.5	24	155	5.5	H50175
PHW 305-E	4,000	2,800	16	8	11.5	24	155	5.5	H50071
PHW 306-E	5,500	3,800	19	8	11.5	24	155	7.5	H50072
PHW 307-E	7,000	4,900	22	8	11.5	24	155	11	H50073
PHW 309-E	9,000	6,300	24	10	14	24	155	15	H50074
PHW 310-E	12,000	8,400	28	8	11.5	24	155	18.5	H50093
PHW 311-E	15,000	10,400	32	7.5	11	23	154	22	H50075
PHW 313-E	18,000	12,400	34	6	9	22	153	22	H50076
PHW 314-E	23,000	16,000	38	6	9	22	153	30	H50177
PHW 315-E	30,000	20,400	44	6	9	20	145	30	H50094
PHW 316-E	37,000	24,500	48	6	9	18	137	45	H50095

## Pneumatic rope winch PHW-L

TYPE	Max. lifting capacity 1st rope layer kg	Max. lifting capacity 5th rope layer kg	Recommended rope diameter mm	Rope speed 1st rope layer m/min	Rope speed 5th rope layer m/min	Rope length in 1st rope layer m	Rope length in 5th rope layer m	Air pressure bar	Air consumption l/sec.	Order No.
PHW 300-LPR2	1,200	845	10	11	16	26	168	7	90	H50119
PHW 301-LPR2	2,100	1,435	12	7	10	24	157	7	90	H50121
PHW 303-LPR2	2,500	1,740	14	6	9	26	165	7	90	H50084
PHW 303-LPR3	2,500	1,740	14	12	17	26	165	7	140	H50122
PHW 305-LPR3	4,000	2,770	16	9	13	25	161	7	150	H50085
PHW 305-LPR4	4,000	2,770	16	15	21	25	161	7	240	H50123
PHW 306-LPR4	5,500	3,970	18	10	14	28	181	7	240	H50086
PHW 307-LPR4	7,000	4,960	22	8	11	26	171	7	240	H50087
PHW 307-LG6	7,000	4,960	22	13	18	26	171	7	350	H50124
PHW 309-LPR4	9,000	6,285	26	6	9	24	163	7	220	H50125
PHW 309-LG6	9,000	6,285	26	10	14	24	163	7	350	H50088
PHW 310-LG6	12,000	8,460	28	7	10	24	168	7	350	H50126
PHW 311-LG6	16,000	10,655	34	5	7.5	19	144	7	350	H50089
PHW 313-LG6	20,000	13,610	38	4	6	19	151	7	350	H50090

## Hydraulic rope winch PHW-H

TYPE	Max. lifting capacity 1st rope layer kg	Max. lifting capacity 5th rope layer kg	Recommended rope diameter mm	Rope speed 1st rope layer m/min	Rope speed 5th rope layer m/min	Rope length in 1st rope layer m	Rope length in 5th rope layer m	Oil differential pressure bar	Flow in l/min.	Order No.
PHW 303-H	2,500	1,740	14	18	26	26	165	140	60	H50077
PHW 305-H	4,000	2,770	16	18	26	25	161	160	80	H50078
PHW 306-H	5,500	3,970	18	25	35	28	181	225	95	H50079
PHW 307-H	7,000	4,960	22	20	28	26	171	230	100	H50080
PHW 309-H	9,000	6,285	26	13	18	24	163	190	100	H50081
PHW 310-H	12,000	8,460	28	11	16	24	168	230	95	H50096
PHW 311-H	16,000	10,655	34	10	15	19	144	230	110	H50082
PHW 313-H	20,000	13,610	38	8	12	19	151	210	120	H50083
PHW 315-H	30,500	20,800	44	8	12	19	151	235	165	H50097
PHW 316-H	37,000	24,570	48	6	9	17	141	225	160	H50098

# Rope winch

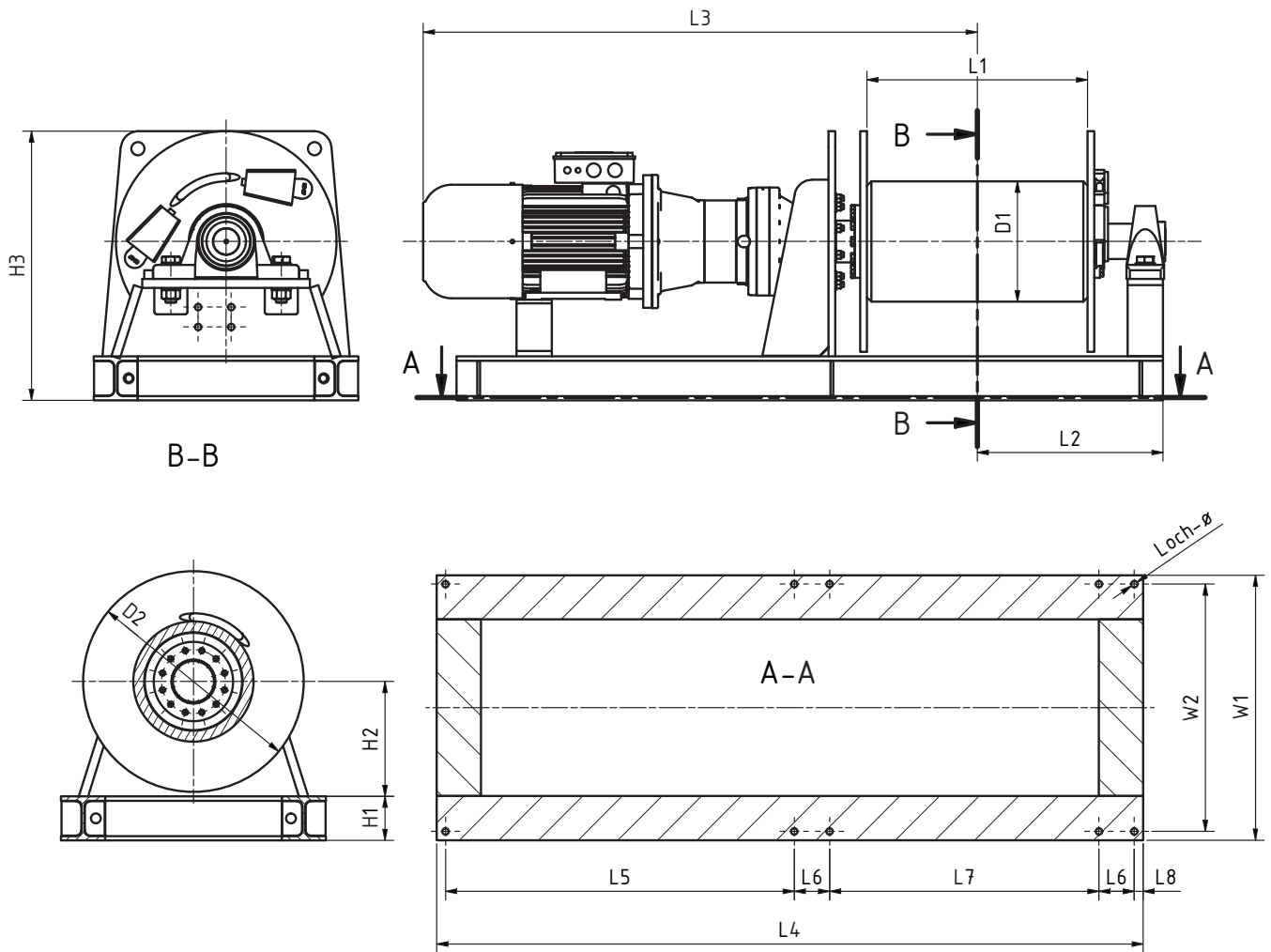

TYPE	Capacity kg	Weight kg	Rope diameter mm	Dimensions (mm)																
				D1	D2	L1	L2	L3*	L4	L5	L6	L7	L8	H1	H2	H3	W1	W2	HEB	Hole ø
PHW-E 300	1,250	200	9	152	300	500	410	1,040	1,450	660	80	590	20	100	215	520	500	460	100	14
PHW-E 301	2,000	230	11	191	375	500	405	1,030	1,450	680	80	570	20	100	215	520	500	460	100	14
PHW-E 304	3,000	360	14	241	430	500	421	1,240	1,600	790	80	610	20	100	260	610	600	560	100	14
PHW-E 305	4,000	425	16	273	500	500	421	1,255	1,600	790	80	610	20	100	260	610	600	560	100	14
PHW-E 306	5,500	460	20	324	580	500	460	1,325	1,800	910	80	690	20	100	300	690	700	660	100	18
PHW-E 307	7,000	720	22	394	680	500	487	1,510	1,950	1,020	100	680	25	120	360	830	800	750	120	20
PHW-E 309	9,000	960	24	419	730	500	502	1,580	2,100	1,035	110	785	30	140	380	890	900	840	140	22
PHW-E 310	12,000	1,520	28	495	860	500	530	1,675	2,200	1,045	120	835	40	160	460	1,070	1,100	1,040	160	26
PHW-E 311	15,000	1,760	32	546	980	500	528	1,875	2,400	1,222	120	858	40	160	510	1,180	1,150	1,090	160	30
PHW-E 313	18,000	2,100	34	572	1,020	500	539	1,970	2,400	1,165	120	915	40	180	585	1,340	1,350	1,290	180	30
PHW-E 314	23,000	2,950	38	660	1,160	500	628	2,190	2,600	1,215	120	1,065	40	200	585	1,360	1,450	1,390	200	32
PHW-E 315	30,000	3,050	44	711	1,350	500	628	2,235	2,600	1,203	140	1,037	40	200	685	1,560	1,550	1,470	200	36
PHW-E 316	37,000	3,500	48	711	1,400	500	634	2,245	2,650	1,402	140	888	40	200	710	1,610	1,600	1,520	200	36

\* May vary depending on the motor version!

## Accessories for PHW series

TYPE	Grooved drum	Cable tensioning device with scored cable drum	Longer cable drum, up to 500 mm	Electric rope winch PHW-E		
				3-layer paint coating*	Drum cover	Spindle limit switch (as an operating limit switch)
PHW 300	Order No. H50206	H50208	H50231	H50450	H50454	H50210
PHW 301	Order No. H50207	H50209	H50232	H50450	H50454	H50210
PHW 303	Order No. H50219	H50217	H50212	H50450	H50454	H50210
PHW 305	Order No. H50219	H50217	H50238	H50450	H50454	H50210
PHW 306	Order No. H50220	H50217	H50213	H50451	H50455	H50210
PHW 307	Order No. H50220	H50218	H50239	H50451	H50455	H50210
PHW 309	Order No. H50221	H50218	H50214	H50452	H50456	H50210
PHW 310	Order No. H50222	H50218	H50215	H50452	H50456	H50210
PHW 311	Order No. H50222	H50218	H50247	H50452	H50456	H50210
PHW 313	Order No. H50223	H50392	H50216	H50452	H50456	H50210
PHW 315	Order No. H50390	H50233	H50393	H50453	H50457	H50210
PHW 316	Order No. H50391	H50233	H50394	H50453	H50457	H50210

\* Acc. ISO 12944 C4 (high) – System C5-M-Marine (very high)

We can offer an adapted control for the PHW winches according to your directions!

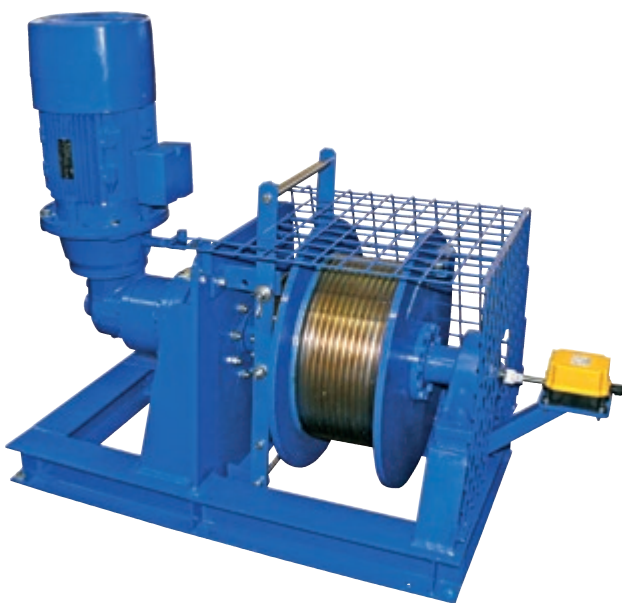

PHW 304-E with angled gear and manual freewheel clutch



PHW 301-E with AISV

## PHW rope winch - customer solution

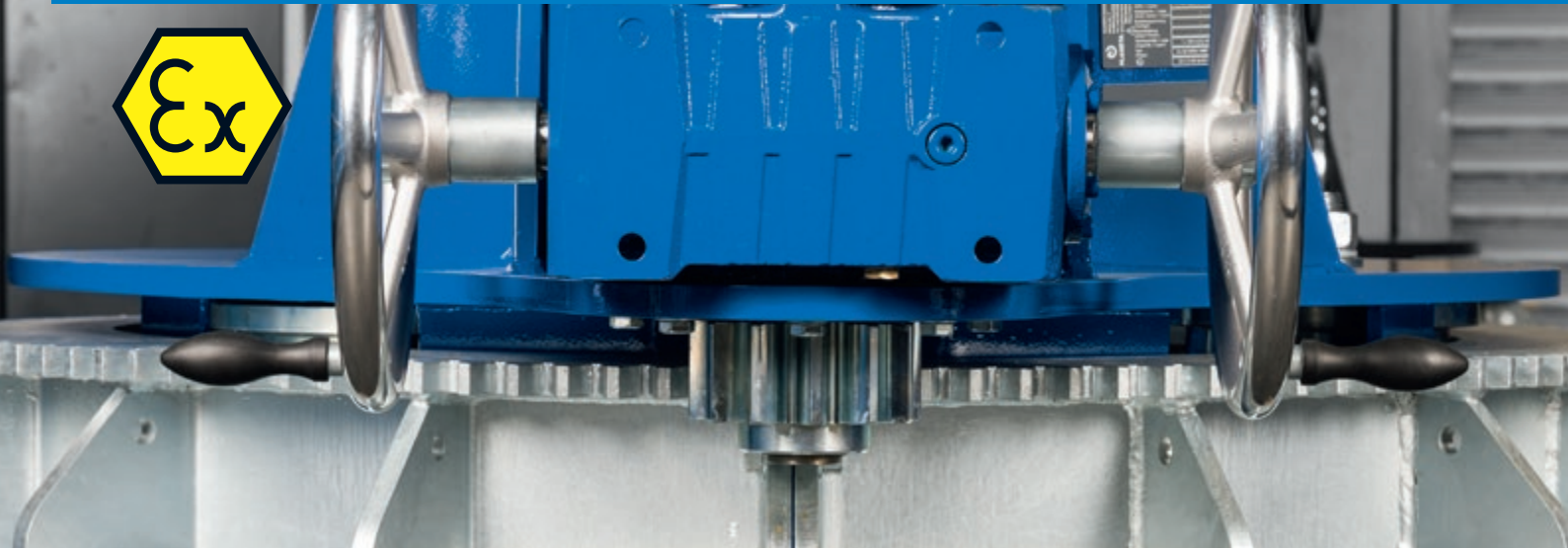

PHW-E 315 electric wire rope winch equipped for use in potentially explosive atmospheres, with a lifting force of 25 tonnes and a lifting distance

of 550 metres. In addition, two PHW-M 306 with a holding force of 4 tonnes and rope lengths of 100 m, as manually operated winches for guiding the load.

They can follow the fixed point on the load because they are rotatably mounted in the base frame.



# ACCESSORIES | OPTIONS



## PLANETA CONTROL ENGINEERING

BASIS-control for hoist, traversing and pulling winches up to 4 kW. Only for PFW-E and PKW-E winches.

### Standard:

- Plastic box IP 55
- Control voltage 24 VDC
- Mains monitoring
- Control switch on 3 m control cable
- Mains plug on 3 m supply cable
- Compatible with TN networks (3Ph)

### Options:

- Mounted and wired to winch
- Overload protection
- Motor temperature monitoring
- Radio control

Motor power kW	Overload protection	Motor temperature monitoring	Mounted and wired to winch	Order No.
1 Ph. / 230 V / 50 Hz				
1.5				H69910
1.5	X			H69911
1.5		X		H69912
1.5	X	X		H69913
1.5			X	H69915
1.5	X		X	H69916
1.5		X	X	H69917
1.5	X	X	X	H69918
3 Ph. / 400 V / 50 Hz				
1.5				H69920
1.5	X			H69921
4.0		X		H69922
4.0	X	X		H69923
1.5			X	H69925
1.5	X		X	H69926
4.0		X	X	H69927
4.0	X	X	X	H69928



Frequency inverter control



Contacteur control

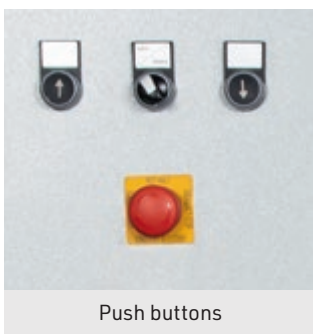

Push buttons

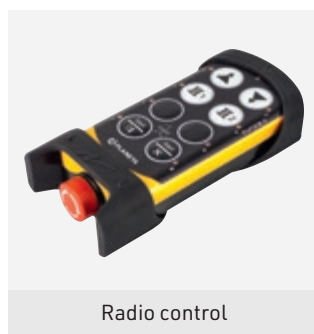

Radio control



Manual control button for contactor control

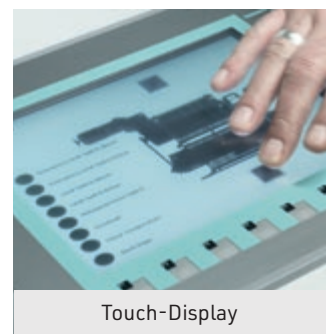

Touch-Display

## PRO-SINGLE SPEED CONTROL FOR HOIST, TRAVERSING AND PULLING WINCHES UP TO 45 KW

### Standard:

- Steel cabinet IP 65
- Control voltage 24 VDC
- Mains monitoring
- Motor temperature monitoring PTC
- Electric overload protection
- Mains isolator
- Control switch on 3 m control cable
- Mains plug on 3 m supply cable
- Compatible with TN networks

### Options:

- Mounted and wired to winch
- Other operating voltages
- Stainless steel cabinets
- Radio control

Motor power 400 V kW	Order No.
5.5	H69933
7.5	H69934
11.0	H69935
15.0	H69936
22.0	H69937
30.0	H69938
45.0	H69939

## PRO-VARIABLE SPEED CONTROL FOR HOIST AND TRAVERSING WINCHES UP TO 45 KW

### Standard:

- Steel cabinet IP 65
- Control voltage 24 VDC
- Frequency converter
- Braking resistor or regenerative unit
- Motor temperature monitoring PTC
- Electric overload protection
- Mains isolator
- Two-stage control switch on 3 m control cable
- Mains plug on 3 m supply cable
- Compatible with TN networks

### Options:

- Mounted and wired to winch
- Other operating voltages
- Stainless steel cabinets
- Radio control

Motor power 400 V kW	Order No.
0.55	H69950
1.1	H69952
1.5	H69954
2.2	H69956
3.0	H69958
4.0	H69960
5.5	H69962
7.5	H69964
11.0	H69966
15.0	H69968
18.5	H69970
22	H69972
30.0	H69974
45.0	H69976

## PRO-VARIABLE SPEED CONTROL FOR PULLING WINCHES UP TO 45 KW

### Standard:

- Steel cabinet IP 65
- Control voltage 24 VDC
- Frequency converter
- Motor temperature monitoring PTC
- Electric overload protection
- Mains isolator
- Two-stage control switch on 3 m control cable
- Mains plug on 3 m supply cable
- Compatible with TN networks

### Options:

- Mounted and wired to winch
- Other operating voltages
- Radio control
- Stainless steel cabinets

Motor power 400 V kW	Order No.
0.55	H69951
1.1	H69953
1.5	H69955
2.2	H69957
3.0	H69959
4.0	H69961
5.5	H69963
7.5	H69965
11.0	H69967
15.0	H69969
18.5	H69971
22	H69973
30.0	H69975
45.0	H69977



## ROPE PULLEY BLOCK | ULRB



PLANETA deflection pulley blocks are designed for demanding wire rope deflections in electrically operated systems and manually operated applications and can withstand the respective full load in any desired deflection direction regardless of their mounting position.

The housings are made of bent sheet steel or welded sheet steel for higher load capacities. The rope pulleys with turned precision grooves in accordance with DIN 15061 and design for drive unit group 1Bm/M3 in accordance with DIN 15020 minimise possible wear on the rope and rope pulley.

The 2RS ball bearings pressed into the rope pulley ensure maintenance-free and quiet running, while the axle holder anti-jump plates secure the bolt and prevent the rope from jumping off the rope pulley. They can also be quickly adjusted by hand to the desired deflection direction.



**Option:** Load measuring pin

### Technical data:

- 8 sizes, total capacities from 500 kg to 14,000 kg
- Full load at 180°-deflection in all directions possible
- Mechanism group 1Bm/M3
- Factor of Safety FoS 4

### Special designs on request:

- Stainless steel version
- Mechanism group 1Am/M4 and 2m/M5 possible for H68121 - H68161
- Load measuring pin

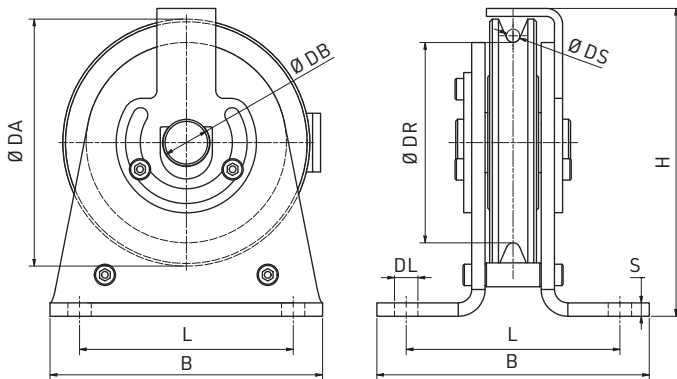

TYPE	ULRB ...	5-75	6-90	8-120	10-150	12-180	14-210	16-240	20-304
Capacity	kg	500	1,000	2,000	3,000	5,000	7,500	10,000	14,000
Rope force with 180° turn max	kg	250	500	1,000	1,500	2,500	3,750	5,000	7,000
Rope diameter max. (DS)	Ø mm	5	6	8	10	12	14	16	20
Groove base diam. of rope pulley (DR)	Ø mm	75	90	120	150	180	210	240	304
Outer diameter of rope pulley (DA)	Ø mm	100	115	150	185	220	260	295	374
Bolt diameter (DB)	Ø mm	15	20	30	35	40	50	60	70
Hole spacing (L)	mm	80	95	130	160	195	230	250	325
Hole diameter (DL)	Ø mm	9	13.5	15.5	17.5	22	26	33	39
Sheet thickness (S)	mm	5	6	8	10	12	15	15	20
Width (B)	mm	104	130	169	204	250	294	330	421
Height (H)	mm	124	144	188	231	274	326	365	462
Weight approx.	kg	2	4	8	14	23	42	55	110
Rope pulley block ULRB	Order No.	H68051	H68061	H68081	H68101	H68121	H68141	H68161	H68201



## SIKA swivel load hook, grade 8

TYPE	Capacity kg	Weight kg	Order No.
WHS-1.25	1,250	0.4	D00150
WHS-1.6	2,000	0.9	D00151
WHS-3.2	3,200	1.6	D00152
WHS-5.4	5,400	3.5	D00153
WHS-8-8	8,000	6.5	D00154
WHS-11.5	11,500	8.5	D00155



## SIKA hook with eye, grade 8

TYPE	Capacity kg	Weight kg	Order No.
OHS-06	1,120	0.6	D00160
OHS-08	2,000	1.0	D00161
OHS-10	3,150	1.5	D00162
OHS-13	5,300	3.5	D00163
OHS-16	8,000	5.5	D00164
OHS-20	12,500	7.6	D00165



## Stainless steel swivel load hook

TYPE	Capacity kg	Weight kg	Order No.
WHN-05	500	0.3	D02151
WHN-1	1,000	1.0	D02152
WHN-2.4	2,400	1.4	D02153
WHN-3.8	3,850	2.3	D02154
WHN-5	5,000	3.8	D02155



## Stainless steel hook with eye

TYPE	Capacity kg	Weight kg	Order No.
OHN-025	250	0.1	D02160
OHN-045	450	0.2	D02161
OHN-1.5	1,500	0.8	D02162
OHN-2.4	2,400	1.4	D02163
OHN-3.8	3,850	3.0	D02164
OHN-5	5,000	4.8	D02165

## Wire ropes

Rope diameter mm	TYPE 6 x 19 + IWRC, 6 x 36 + IWRC (as of 10 mm) 1960 N/mm <sup>2</sup> galvanised, non-rotation resistant		TYPE 17 x 7 + IWRC, 1960 N/mm <sup>2</sup> galvanised, rotation resistant		plus assembly of the rope on reel if necessary / one side pointed, other side with thimble Order No.
	Min. breaking force kN	Order No. per metre	Min. breaking force kN	Order No. per metre	
4	10.4	C04619	10.3	C04177	C04001
5	16.2	C05619	16.1	C05177	C05001
6	23.4	C06619	23.1	C06177	C06001
7	31.8	C07619	31.5	C07177	C07001
8	41.6	C08619	41.1	C08177	C08001
9	52.7	C09619	52.1	C09177	C09001
10	69.8	C10636	64.3	C10177	C10001
11	84.4	C11636	77.8	C11177	C11001
12	100.5	C12636	92.6	C12177	C12001
13	118	C13636	109	C13177	C13001
14	136.8	C14636	126	C14177	C14001
16	178.7	C16636	165	C16177	C16001
18	226.2	C18636	208	C18177	C18001
20	279.3	C20636	257	C20177	C20001
22	337.9	C22636	-	-	C22001
24	402.2	C24636	-	-	C24001
26	472	C26636	-	-	C26001
28	547.4	C28636	-	-	C28001

## WIRE ROPES AND LIMIT STOP EQUIPMENT

In the majority of cases, wire ropes in accordance with DIN EN 12385-4 are used. Depending on the application, we also equip cable winches with high-strength wire ropes or stainless steel ropes. The ropes differ in terms of their different designs, e.g. flexibility, strength and robustness.

For unguided loads lifted in a single line, a wire rope must be selected that does not untwist under load. These ropes belong to the group of rotation-resistant wire ropes. The rope type is selected according to your application. It is helpful to have as many parameters as possible to make the right choice.

Due to the large number of different ropes, the PLANETA PFW, PCW and PHW wire rope winches are offered without rope in the basic version. You can choose between a smooth rope end, a crimped end or a crimped end with load hook as a sling.

Wire ropes are supplied loose in a bundle as standard.

We can also coil the rope on request.



## Stainless steel wire ropes

Rope diameter mm	TYPE 7 x 19 1570 N/mm <sup>2</sup> stainless steel (V4A) non-rotation resistant		TYPE 18 x 7 1570 N/mm <sup>2</sup> stainless steel (V4A) rotation resistant		plus assembly of the rope on a reel if necessary / one side pointed, other side with thimble Order No.
	Min. breaking force kN	Order No. per metre	Min. breaking force kN	Order No. per metre	
4	8.34	C04719	9	C04187	C04002
5	13	C05719	13	C05187	C05002
6	18.7	C06719	19	C06187	C06002
8	33.3	C08719	34	C08187	C08002
9	-	-	-	-	-
10	52.1	C10719	53	C10187	C10002
11	-	-	-	-	-
12	75	C12719	77	C12187	C12002
13	-	-	-	-	-
14	102	C14719	107	C14187	C14002
16	133	C16719	135	C16187	C16002

Design:

6 x 19 + IWRC, 6 x 36 + IWRC: Robust winch rope with independent wire rope core

17 x 7 + IWRC: High tensile lifting rope, twist-poor

7 x 19, 18 x 7: Stainless Steel: Corrosion free rope from material 1,4401

# Rope winch accessories

## WIRE CABLE BLOCKS

With rotatable load hook in accordance with DIN 15401, with hook clip.

**PA/R** = with polyamide roller(s) with slide bearing  
up to 150 mm external roller diameter

**ST/R** = with steel roller(s) with plain bearing

**ST/K** = with steel roller(s) with ball bearing

### Wire cable block, single-roll



Load bearing capacity at hook t	Roller outer Ø mm	Roller basic Ø mm	Max. wire rope Ø mm	Housing-width mm	Base width mm	Axis length mm	Installation length at hook mm	Weight approx. kg	Order No. PA/R	Order No. ST/R	Order No. ST/K
500	100	80	7	130	25	55	385	3.5	D01500	D01508	D01516
1,000	125	105	9	150	30	55	430	4.5	D01501	D01509	D01517
2,000	150	125	11	165	33	65	500	7.5	D01502	D01510	D01518
3,000	175	145	12	210	41	82	640	15	-	D01511	D01519
3,000	200	170	15	210	41	82	640	15.5	-	D01512	D01520
5,000	225	185	16	265	45	85	740	24	-	D01513	D01521
5,000	250	210	18	265	45	85	740	25	-	D01514	D01522
8,000	310	260	23	325	52	110	890	45	-	D01515	D01523

### Wire cable block, double-roll



Load bearing capacity at hook t	Roller outer Ø mm	Roller basic Ø mm	Max. wire rope Ø mm	Housing-width mm	Base width mm	Axis length mm	Installation length at hook mm	Weight approx. kg	Order No. PA/R	Order No. ST/R	Order No. ST/K
1,000	100	80	7	130	30	81	410	5	D01530	D01537	D01544
1,600	125	105	9	150	33	86	440	7	D01531	D01538	D01545
3,000	150	125	11	165	41	113	525	12	D01532	D01539	D01546
5,000	175	145	12	210	45	130	680	23	-	D01540	D01547
5,000	200	170	15	210	45	130	680	24	-	D01541	D01548
8,000	225	185	16	265	52	150	785	38.5	-	D01542	D01549
8,000	250	210	18	265	52	150	785	40.5	-	D01543	D01550

### Wire cable block, single-roll, hinged



Load bearing capacity at hook t	Roller outer Ø mm	Roller basic Ø mm	Max. wire rope Ø mm	Housing-width mm	Base width mm	Axis length mm	Installation length at hook mm	Weight approx. kg	Order No. PA/R	Order No. ST/R	Order No. ST/K
500	100	80	7	130	25	55	350	3.5	D01560	-	D01576
1,000	125	105	9	150	30	61	390	4.5	D01561	-	D01577
2,000	150	125	11	165	33	73	435	7.5	D01562	-	D01578
3,000	175	145	12	210	41	90	580	15	-	D01571	D01579
3,000	200	170	15	210	41	90	580	15.5	-	D01572	D01580
5,000	225	185	16	265	45	105	700	24	-	D01573	D01581
5,000	250	210	18	265	45	105	700	25	-	D01574	D01582
8,000	310	260	23	325	52	120	810	41	-	D01575	D01583

Other sizes on request.

## HIGH-STRENGTH GALVANISED SHACKLE



### Design A | G 209

(curved) with eye bolt

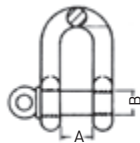

### Design B | G 210 (straight) with eye bolt

(Dimensions the same as design A)



### Design C | G 2130

(curved with nut and cotter pin)

(Dimensions the same as design A)



### Design D | G 2150

(straight with nut and cotter pin)

(Dimensions the same as design A)

Capacity kg	Nominal size, inches	Bore (A) mm	Bolt Ø (B) mm	Order No. Design A	Order No. Design B	Order No. Design C	Order No. Design D
*330	3/16	9.65	6.35	D00278	-	D00312	-
500	1/4	11.9	7.87	D00279	D00296	D00313	D01191
750	5/16	13.5	9.65	D00280	D00297	D00314	D01192
1,000	3/8	16.8	11.2	D00281	D00298	D00315	D01193
1,500	8/16	19.1	12.7	D00282	D00299	D00316	D01194
2,000	1/2	20.6	16	D00283	D00300	D00317	D01195
3,250	5/8	26.9	19.1	D00284	D00301	D00318	D01196
4,750	3/4	31.8	22.4	D00285	D00302	D00319	D01197
6,500	7/8	36.6	25.4	D00286	D00303	D00320	D01198
8,500	1	42.9	28.7	D00287	D00304	D00321	D01199
9,500	1 1/8	46	31.8	D00288	D00305	D00322	D01200
12,000	1 1/4	51.5	35.1	D00289	D00306	D00323	D01201
13,500	1 3/8	57	38.1	D00290	D00307	D00324	D01202
17,000	1 1/2	60.5	41.4	D00291	D00308	D00325	D01203
25,000	1 3/4	73	51	D00292	D00309	D00326	D01204
35,000	2	82.5	57	D00293	D00310	D00327	D01205
55,000	2 1/2	105	70	D00294	D00311	D00328	D01206

\* Only as eye bolt available.



Frequency converter control system



Contactor controller



Selector switch



Mains isolator



Wall-mounted switch



Manual control button for contactor controller



Radio control

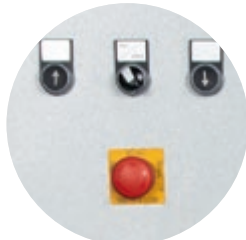

Push buttons



Device attachment plug



Mains connection cable



Foot switch



Touch-Display

## CONTROL

PLANETA control systems provide the optimum interface between your PLANETA winch and your application or safety concept. In the basic version with constant speed the following sources of error are automatically monitored and safely blocked:

- Mains monitoring: phase failure, undervoltage and phase sequence (series, always)
- Thermal overload of the motor (from 2,000 W motor power)
- Torque overload (too high load, from 1,000 kg)

Further safety aspects are the control circuit with low-voltage voltage, which is galvanically isolated from the power supply system, and the stable control boxes with a high protection class. You can choose between various operating options, including several, the control of different winches, individually and simultaneously, versions according to UL/CSA GOST or ATEX guidelines. If your application requires exact positioning, particularly smooth acceleration, variable speeds, automatic travel cycles, variable tensioning forces, even when the winch is at a standstill, we can extend your control system with a frequency converter. The parameterization comes directly from our company, based on many years of experience with the top product of the hoisting industry.

## Operation

You have the option of controlling the cable winch using pushbuttons in the switch cabinet door, using a manual control button, a wallmounted switch, a foot switch, a radio controller or a combination of several operations. The prerequisite for this is that you use a contactor controller or a frequency converter controller. Each of the operations contains the „UP“ and „DOWN“ pushbuttons and an „EMERGENCY STOP“ palm switch. If you require additional operating points, you can select the desired operating point on a selector switch on the switch cabinet door.

## Control options

The power cord or the device attachment plug provide the winch with an electrical connection to the mains and consist of the desired length of connection cable and one of the plugs that correspond to the cable winch's operating voltage and power. A mains isolator can be used to power off the cable winch (e.g. for servicing purposes) in the same way as a mains connection plug also can. The electrical overload protection is integrated into the motor circuit and switches the winch off automatically if the load is too great.

## Rope winch options



### Grooved drum

Rope drums in the PFW, PCW and PHW series are smooth as standard. To enable longer rope service lives and a shorter distance to the first deflection, it is recommended that the rope drum is grooved.

### Emergency hand crank

Up to a certain size, we can equip the PLANETA PFW and PKW rope winches with emergency crank handles. Therefore, if there is a loss of electrical power, you can raise or lower the load by hand.



### Drum protection

Covering the cable drum prevents objects or items of the operator's clothing entering the cable drive. This reduces the risk of accidents and damage to the winch.

### Manual brake venting

The PLANETA PHW rope winches can be equipped with manual brake venting. Therefore, if there is a loss of electrical power, you can lower the load by hand by bleeding the spring-loaded brake using the release lever.



### Drum pressure roller

If the rope is wound or unwound unloaded, the rope pressure roller supports orderly winding onto the rope drum. A typical application is, for example, when the rope winch has a freewheel clutch. The best effect is achieved with a combination of grooving and rope pressure roller.

### Brake active on drum

The (manual and automatic) cable drum brake is an additional brake that only applies to the cable drum. It can be an additional piece of safety equipment; e.g. for hoist winches with a free-wheeling coupling or for hoist winches to transport people.

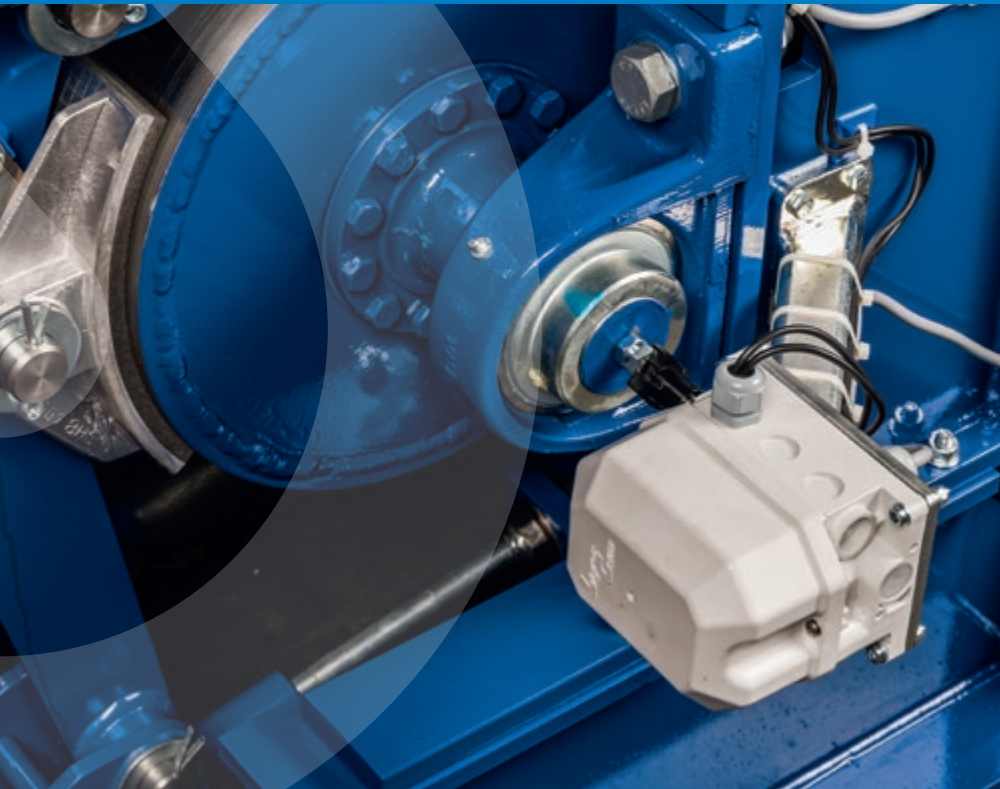

### Slack wire switch

A slack wire switch determines whether the cable is laden or unladen. The cable winch is switched off automatically once the load is set down. This is advantageous for example in filling stations.



### Spooling device

If you cannot comply with the distance to the first deflection due to space limitations, we can offer an optional spooling device. The cable is fed through a reel that moves forwards and backwards in a line in front of the cable drum, thereby ensuring that the cable is wound around the cable drum in an orderly manner. The reel is coupled to the cable drum mechanically. The system works automatically. In this way, the spooling device increases the cable's angle of deflection and shortens the distance to the first deflection.



### Spindle limit switch

The spindle limit switch is coupled directly to the rope drum and determines the drum's revolutions. You can determine the cable winch's shut-off positions as required by adjusting the switching cam inside the switch. As standard, our spindle limit switches have two contacts, in order to limit the top and bottom hook position for example. We can equip the switch with up to five contacts on request. Therefore, you can switch something at interim positions (e.g. the alarm horn) or switch to a lower speed with rope winches that have two speeds.



### Disengaging clutch

You can uncouple rope drums of PLANETA PFW, PKW and PHW cable winches from the braked drive using the freewheel clutch. The rope can then simply be unwound by hand and does not have to be unwound by motor at rope speed. Freewheel clutches are only permitted for pulling winches. The grooved drum and rope pressure roller options are recommended to support the orderly winding of the unloaded rope.

## Drive type

Manually operated rope winches are operated by the operator's manual force via a crank handle. The power is therefore limited to a certain value which is mainly generated by the pulling force and the cable speed. The higher the pulling force, the lower the cable speed if the power remains the same.

Electrically-operated cables are driven by three-phase motors or alternating current motors. Three-phase motor powers of up to 30 kW are available in our standard version. Higher powers are available on request. Due to the mains-related limitations, the power is limited to 2.2 kW when using alternating current motors.

Hydraulically-operated rope winches are operated by orbital motors or radial piston motors depending on the power. We will either work with your existing hydraulic supply or we will provide a unit. In the standard version, we install brake valves for a secure hold.

Pneumatically-operated rope winches are operated by multi-disc motors or radial piston motors depending on the power. We can provide compressed air rope winches with power of up to 22 kW. Please specify your compressed air supply data. Depending on the design, we will equip the rope winches with pneumatic allyactuated spring-loaded brakes.

## Cable speed

PLANETA rope winches normally have a constant cable speed. The PFW, PCW and PHW PLANETA rope winches can be designed for virtually any cable speed.

Thanks to appropriate motors that can operate at two speeds or thanks to freely-programmable frequency converter controllers, multiple speeds can also be achieved.

## Site of operation

Do you have a height restriction, such as a maximum distance to the first deflection? In that case, we can construct the cable winch to fit as well as possible. If the winch has to be protected against wind and weather, or even against salt water, we can provide motors with higher protection classes, special thick protective coatings or complete housings.

## Load type

There are four different safety classes for PLANETA rope winches. These start with the standard cable winch according to DGUV norm 54 (D8) (German employers' insurance association), which you can use to transport or lift goods. You must prevent people standing in the region of or under the load. Next, we have the BGV D8+ cable winch designs, which guarantee safety for people under a suspended load if the cable winch is electrically shut down. Cable winches in accordance with DGUV norm 17 (C1) also allow people to remain under the suspended load safely. In the highest safety classes, people may also be carried.

## Two or more cable outflows

In order to be able to lift long cross beams or frames with large bases, you require several lifting points on the load to ensure that the load does not tip. We can equip our rope winches with multi-cable drums for this purpose. Please let us know the number of load points and the distance between them.



## Explosion protection class

The PFW, PCW and PHW rope winches can be designed for use in locations at risk of explosion. Please inform us of the explosion protection class required. Further information can be found in our catalogue for ATEX hoists.

**Rope Speed = Constant \* r**  
**Rope Tension = Constant / r**

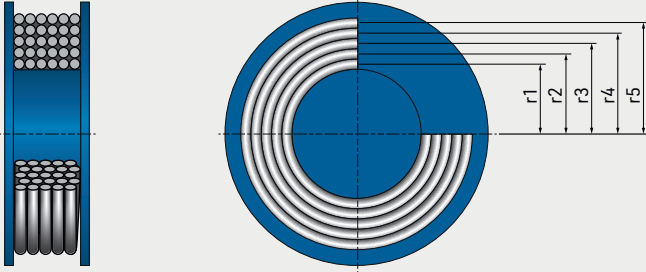

### Information on multi-layer wound cable drums:

Cable drums are normally wound in multiple layers; i.e. the cable is wound around the cable drum layer by layer. The lever that the cable uses to transfer the pulling force to the cable drum becomes larger with each cable layer. However, the gear data such as the driving torque and the driving speed remain constant. Due to this, the cable speed increases and the pulling force decreases with each cable layer that is wound up.

### Information for safe operation:

To ensure that the cable is wound onto the rope drum in an orderly manner, the cable's permitted angle of deflection must not be exceeded. For this reason, the cable is normally guided from the cable drum over a fixed deflection roller at first. This is aligned in the centre of the drum at a specified distance from the cable drum. This prevents the angle of deflection being exceeded. This distance mainly depends on the drum length and the relationship between the drum diameter and the cable diameter, and is specified in each quotation.

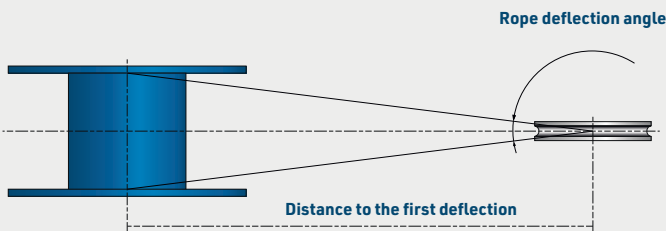

## § info

The following applies according to the machinery directive:

- Overrunning structural or required limits whose movement is generated by the cable winch must be prevented by limit switches. (Normally by spindle limit switches)
- The rope drum and other moving parts must be inaccessible or protected against drawing in. (Normally by covers)
- Rope winches with a lifting capacity of over 1,000 kg must be protected against an overload. (Normally by electrical overload protection in the switch cabinet)
- The electrical controller must be able to be powered off. (Normally by a mains plug or a mains isolator)
- The customer must ensure that the base to which the winch is fixed is structurally stable.



PLANETA AT TRACEPARTS  
**YOUR 3D MODEL ALREADY ONLINE!**

As a product developer or engineer, you can significantly speed up the process of your projects considerably by using TracePartsOnline.net.

This is a powerful tool, that gives you immediate and free access to over 100 million 3D models and 2D CAD drawings.

PLANETA PFW winches can now also be configured online by anyone at Traceparts! You can integrate the finished 3D CAD data into your design in just a few steps!

A brief visual assessment is possible before downloading: You can view all 3D models in the desired configuration in a viewer - all in your browser.

Save important time during development work, as there is no need to redraw purchased components.

**1. Select your rope winch type.**



**2. Configure your winch.**



**3. View your winch in full screen mode.**



## 1. Kind of drive and quantity\*

- manually
- electric, operating voltage  phases /  VAC /  Hz
- pneumatic, flow volume  l/sek  bar
- hydraulic, flow volume  l/min  bar
- Requested quantity

## 2. Site of Operation and capacity\*

- Pulling winch  
 daN pulling force and  m rope length
- Lifting winch  
 kg Hubblast and  m rope length
- Traversing winch  
 daN pulling force and  m rope length

If the pulling or lifting capacity is not known, please describe your application with the length of the path, weight of load and rolling conditions for your pulling applications. For lifting applications please also describe the angle or slope of the path.

## 3. Rope speed

- slow (1-5m/min)       medium (5-15m/min)
- fast (>15m/min)       exactly ..... m/min
- adjustable from  m/min up to  m/min
- 2-speed  m/min and  m/min

## 4. Site of Operation

- Distance to the first reeving  m
- inside     outside     outside with seawater

## 5. Load type

- Goods     Pending goods above people
- Goods to be moved above people     People
- Load guided                       Load not guided

## 6. Winch options

- Rope  m                       Rope enclosed loose
- Rope coiled                       Rope-end, plain
- Rope-end with thimble  Load hook

- Grooved drum                       Drum pressure roller
- Spindle limit switch               Slack wire switch
- Disengaging clutch               Spooling gear
- Drum guard
- Second brake acting on drum
  - mechanic                       automatic
- Emergency crank                   Manual brake release
- Two rope exits with  m distance
- More rope exits like shown on sketch
- Explosion-proof protection class:**

## 7. Steuerung

- Low voltage control box
  - Panel mounted on winch frame
  - for mounting on walls, with  m distance to winch
- Frequency inverter
  - mounted on winch frame
  - for mounting on walls, with  m distance to winch

## 8. Operation

- Push buttons in the control panel door
- Pendant control with  m control cable
- Radio Remote control
- Wall-mounted push-button
- Foot pedal
- Several with selector switch in the control panel door

## 9. Options for control

- Panel mounting appliance inlet
- Power supply cable with  m cable
- Power shut-off switch
- Electric overload protection
- Full motor protection (Temperature monitoring)

## 10. Other requirements

## 11. Please sketch your application as required on a DIN A4 sheet of paper

\* Please note the required fields!

Company

Contact person

Adress

Phone

E-Mail

Company stamp / Signature





**PLANETA - Hebetchnik GmbH**

Resser Straße 17 · 44653 Herne · Germany · Phone: +49 (0) 2325 9580 0 · Fax: +49 (0) 2325 77077  
info@planeta-hebetechnik.de · www.planeta-hebetechnik.de

