

## EN: Translated version of the original instruction manual

### Electric construction winch BW (80 - 300) kg



**!** Dear Customer,  
Thank you very much for purchasing our device. We value your trust in our brand and hope you are satisfied with your purchase. If you have any questions or problems, please do not hesitate to contact us. Have fun with your new device!

**!** Read these instructions carefully before use and keep them safe.

**!** Please note the serial number and the corresponding dimensions before using it for the first time.

Serial number: \_\_\_\_\_

Hook:

g= \_\_\_\_\_ mm

b= \_\_\_\_\_ mm

h= \_\_\_\_\_ mm

Wire rope:

d= \_\_\_\_\_ mm

l= \_\_\_\_\_ m

Construction= \_\_\_\_\_

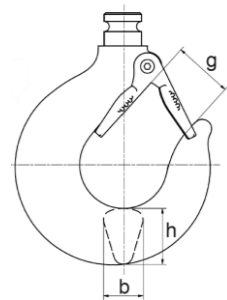

First edition 10-2023 (Version 1)  
PLANETA-Hebetechnik GmbH  
Resser Str. 17 | 44653 Herne | Germany





# Table of contents

1	Introduction .....	1
1.1	General information .....	1
1.2	Information on the manufacturer .....	1
1.3	CE declaration and declaration of incorporation .....	1
1.4	Copyright.....	1
1.5	Warranty.....	1
1.6	Definitions.....	2
2	Safety.....	3
2.1	Safety information .....	3
2.2	Regulations and directives .....	3
2.3	Personal protective equipment.....	3
2.4	Duties of care and requirements .....	4
2.5	Intended and non-intended uses .....	5
2.5.1	Intended uses .....	5
2.5.2	Misintended uses .....	5
2.6	Symbols, Bid Signs, and Signal Words .....	6
2.7	Basic ideas.....	7
2.7.1	Duty cycle ED in %.....	7
2.7.2	Switching cycles s/ & circuits c/h .....	7
2.7.3	Degrees of protection.....	7
2.7.4	FEM 9,511 .....	8
2.8	Hazards according to DIN EN ISO 12100.....	9
2.8.1	Mechanical hazards .....	9
2.8.2	Electronic Hazards .....	9
2.8.3	Material and/or substantial hazards .....	9
2.8.4	Acoustic hazards .....	9
2.9	Residual risks.....	10
2.9.1	General residual risks.....	10
2.9.2	General Types of Residual Risks:.....	10
3	Assembly, installation and commissioning .....	11
3.1	Devices and component installations.....	12
3.1.1	Device suspension .....	12
3.1.2	Power & Control Cables .....	14
4	Product description .....	15
4.1	Area of application .....	15
4.1.1	Committee of use.....	15
4.2	Type Shield/ER .....	15
4.3	Schematic diagrams .....	16
4.4	Specifications .....	17
5	Operation .....	18
5.1	General information .....	18
5.1.1	Overtightening of the rope drum .....	18
5.2	Direction of rotation of the wire rope .....	19
5.3	Control Bottle .....	19
6	Storage and transport.....	20
6.1	General information about transport .....	20
6.1.1	Before transport: .....	20
6.1.2	During transport:.....	20
6.1.3	After transport:.....	20
7	Maintenance .....	21
7.1	General information .....	21
7.2	Maintenance.....	21
7.2.1	Inspection .....	21
7.2.2	Maintenance .....	21
7.2.3	Restoration .....	21
7.2.4	Spares .....	21
7.3	Inspection and maintenance interval .....	23
7.4	Inspection & Maintenance Plan .....	24
7.4.1	Visual inspections.....	24

7.4.2	Functional tests.....	24
7.4.3	Lubrication.....	24
7.5	Replacement of components and materials.....	25
7.5.1	Wire rope change.....	25
7.5.2	Replacing the carbon brushes.....	25
7.5.3	Oil change.....	25
8	Troubleshooting and fault rectification.....	26
8.1	Faults.....	26
8.2	Causes of malfunctions and measures.....	26
9	Decommissioning and disposal.....	27
9.1	Decommissioning and disposal.....	27
10	Documents and Annexes.....	28
10.1	Declaration of Conformity of a complete Machine.....	28
10.2	Declaration of Conformity of an incomplete Machine.....	29
10.3	Circuit diagram.....	31
10.4	Wiring diagram (standard).....	31
10.5	Circuit diagram (with EMERGENCY STOP).....	31
10.6	Spare parts BW 80 -230.....	32
11	Notes.....	33

## 1 Introduction

---

### 1.1 General information



Read these instructions carefully before use and keep them in a safe place.



These instructions provide information on proper commissioning, intended use and safe and efficient operation and maintenance. The operating instructions are an integral part of the product. The illustrations shown in these operating instructions are for basic understanding and may differ from the actual design.



Fitters, operators and maintenance personnel must observe in particular the operating instructions and the documentation provided by the employers' liability insurance association.



Please observe their local regulations and rules. Information on safety, installation, operation, testing and maintenance from these operating instructions must be made available to the appropriate persons. Make sure that these operating instructions are available in close proximity to the product during the period of use of the product.

### 1.2 Information on the manufacturer

Name:	PLANETA-Hebetechnik GmbH	E-Mail:	info@planeta-hebetechnik.de
Adresse:	Resser Str. 17   44653 Herne   Germany	Phone:	49-(0)-2325-9580-0

### 1.3 CE declaration and declaration of incorporation



A ready-to-use machine with all its associated safety devices has a CE declaration of conformity and is labelled with a CE mark. Incomplete machines are supplied without a CE mark and only contain a Declaration of Incorporation in accordance with the current Machinery Directive.

### 1.4 Copyright



These original operating instructions are protected by copyright. The authorised user has a simple right of use within the scope of the purpose of the contract. Any modified use or exploitation of the contents provided, in particular reproduction, modification or publication of any deviating kind, is only permitted with the prior consent of the manufacturer. If the operating instructions are lost or damaged, a new copy can be requested from the manufacturer. The manufacturer has the right to change the operating instructions without prior notification and is not obliged to replace earlier copies.

### 1.5 Warranty



The warranty is contractually regulated (see General Terms and Conditions or contract).

Warranty and liability claims for personal injury and damage to property are excluded if these are due to one or more of the following causes:

- Improper use of the device.
- Improper operation and maintenance of the device and improper commissioning.
- Failure to follow the instructions in the operating instructions.
- Unauthorized structural changes to the device.
- Disasters caused by foreign bodies and force majeure.
- Inadequate monitoring of equipment parts that are subject to wear and tear.
- Improperly performed repairs.
- Wear parts are not covered by liability for defects.
- We reserve the right to make technical changes to the device in the context of improving the performance characteristics and further development.

## Introduction

### 1.6 Definitions



For the purposes of this document

- Qualified professional:** A qualified professional is a person who has specific knowledge, skills and experience in a particular field. These professionals usually have formal training or relevant work experience that qualifies them for their job. They are able to perform complex tasks independently and responsibly and bring a high level of expertise to the job. Qualified professionals are employed in various fields such as engineering, medicine, IT, crafts, education, management and many others.
- Competent person:** Qualified persons for testing are persons who have the required specialist knowledge due to their technical training, knowledge and experience as well as their recent professional activity. The exact requirements for qualification are specified in the relevant regulations and codes of practice. As a rule, these are specialists for occupational safety, experts for the inspection of work equipment or persons with comparable qualifications. However, the exact qualification and competence depends on the type and scope of the inspection. It is important to ensure that the person appointed has the necessary expertise and can carry out the inspection properly.
- Expert:** An expert is a "recognised competent person" who, due to his professional training and experience, has knowledge in the field of the work equipment to be tested and is familiar with the relevant state occupational health and safety regulations, regulations of the employers' liability insurance association and generally recognised rules of technology. This competent person must regularly inspect and assess work equipment of the appropriate design and regulations. This qualification is granted by approved inspection bodies.
- Electronic specialist:** An electronic specialist is a person who has specific knowledge and skills in the field of electronics. He is able to install, maintain and repair electronic equipment.
- Hoist:** Hoist is the generic term for all equipment used to move or lift weights (loads).
- Device:** A device is a technical appliance or machine designed to perform a specific function or task. It can be operated electronically, mechanically or manually and consists of various components that work together to achieve the desired result.
- Crane:** A crane is a lifting device that can lift loads with a load-bearing device and also move them in one or more directions.
- Lifting equipment:** Lifting equipment is equipment that is permanently attached to the hoist, e.g. ropes, chains, lifting beams, grabs, crane hooks, tongs. They are permanently installed in the hoist and are used to take up slings, load handling attachments or loads.

## 2 Safety

### 2.1 Safety information



Most accidents when handling technical equipment are due to disregard of basic safety rules. Recognising a possible hazard can prevent an accident before it occurs.



Disregarding the safety instructions can result in death or serious injury. As the manufacturer of the appliance, we cannot foresee all possible circumstances that may contain potential hazards. Consequently, the safety instructions in this manual are not all-inclusive.



The appliance must not be used in any way that deviates from the considerations in this manual. All applicable safety regulations and protective measures at the place of use must be observed, including site-related regulations and protective measures at the workplace.



Information, descriptions and illustrations in this manual are based on information available at the time of writing.

### 2.2 Regulations and directives



Please take into account the current rules and regulations in your country. The guidelines listed here may not apply to every single device or machine.

Table 1 European directives & regulations

European directives & regulations	
Regulation-2023/1230 EU L165/1	Machinery Product Ordinance
Directive- 2014/34/EU L 96/309	ATEX-Directive**
Directive-2014/53/EU 02014L0053	Funkanalgen-Directive*
Directive-2014/30/EU	EMV-Directive*
Directive-2012/19/EU L197/38	WEEE-Directive*
Directive-94/62/EG 01994L0062	Packaging -Directive
Directive-2011-65/EU L174/88	RoHS-Directive*
Regulation-1907/2006 L136/3	REACH-Regulation

\*These listed directives only apply to motor-driven devices or those equipped with an RFID chip.

\*\* These listed directives only apply to equipment used in potentially explosive atmospheres.

### 2.3 Personal protective equipment



Appropriate work clothing must be worn for each task.

For safety reasons, operators and other persons in the immediate vicinity of the machine must wear personal protective equipment (PPE). There are different types of protective equipment that must be selected according to the requirements of the working environment. The chapter "Symbols, command signs and signal words" lists the Personal Protective Equipment that must be worn as a minimum.

## Safety

### 2.4 Duties of care and requirements



The requirements for safeguarding safety and health have been met. However, this safety can only be achieved in operational practice if all necessary measures are taken. The operator of the device must plan these measures and control their execution. The operator is responsible for safe operation. The operator must ensure that the operating and maintenance personnel are instructed in good time before any work is carried out with or on the equipment. Due to the risk of injury caused by e.g. getting caught or pulling in, these personnel are not allowed to wear loose clothing, open long hair or jewelry, nor rings. Persons under the influence of drugs, alcohol or drugs that affect their ability to react must not carry out any work with or on the product. The user must have the necessary instruction and experience, as well as any necessary tools, to be able to carry out work on and with the device. Personnel to be trained may only work on the component under the supervision of an experienced person. The user must also have sufficient physical and mental abilities.



It is essential to follow the safety instructions for the device, as failure to do so can result in serious injury or even death. As a manufacturer, we cannot anticipate all potential hazards, so the safety instructions in this guide are not all-encompassing. No work may be carried out if the relevant information has not been read and understood. The user is responsible for ensuring the safety of himself and others in the event of deviations from the work equipment, actions, working methods or working techniques suggested by the manufacturer.

## 2.5 Intended and non-intended uses

### 2.5.1 Intended uses



The intended use of the stationary electric construction winch is to move or hold goods such as machinery and machine components, building materials, containers, etc. in a vertical direction, as long as the weight of these goods is below the load capacity of the device.



It is the responsibility of the user or operator to ensure that the electric construction winch is used in accordance with the applicable regulations and standards. Improper use can pose an increased risk of accidents and damage. Therefore, the electric construction winch should only be used for its intended purposes and within its load capacity and specification limits. It is recommended to contact recognized professionals or experts in the crane industry for accurate information and advice that complies with local regulations.

### 2.5.2 Misintended uses



Misintended uses are those in which the above-mentioned device is not used in accordance with the intended conditions of use and safety regulations. These include, but are not limited to:

- Improper attachment of the load: Using the above device without properly fastening the load, which can lead to an increased risk of accidents.
- Improper use: The electric construction winch must be operated in such a way that there is always a remaining winding of the rope of 5 safety windings on the rope drum.
- Use in an environment with explosive or flammable materials: The above equipment without a specification change must not be used in areas where explosive or flammable materials are present, as this may lead to hazardous situations.
- Use in an environment with strong vibrations or shocks: The above device should not be used in environments with high vibration or shock, as this may cause damage to the device.
- Use in an environment with harsh chemicals: The above device must not be used in areas where aggressive chemicals are present, as this may cause corrosion and damage to the equipment.
- Improper maintenance and inspection: Neglect of regular maintenance and inspection of the above device can lead to malfunctions and safety risks.
- Use without proper training and qualifications: Persons operating the above device must have the necessary training and qualification to ensure that it is used properly.
- Use without proper monitoring during operation: The above device must be constantly monitored during operation to ensure that it is working properly and does not show any signs of wear or damage.
- Use without adequate safety distances from other work areas or obstacles: The above equipment should always be used at a sufficient distance from other work areas or obstacles to avoid collisions or other accidents.
- Use without adequate safety precautions: The above device should always be used taking into account the necessary safety precautions, such as wearing personal protective equipment or setting up barriers in the work environment.
- Use without adequate protection against accidental fall of the load: The above-mentioned equipment must always be equipped with appropriate safety devices to prevent the load from falling unintentionally.
- Tampering with or modifying the device: Any tampering or modification of the above device without the manufacturer's permission may cause security problems and void the warranty.
- Use for passenger transport: The above device is not designed for the carriage of passengers and may therefore not be used for this purpose.
- Use without proper verification of the load capacity of the suspension point: Before using the above device, it should always be checked that the suspension point can safely support the load.



Please note that the above examples of improper use of the above device are only excerpts and do not fully cover all possible scenarios. They are only intended as a guide to give you an overview of potential risks. It is important to emphasize that the responsibility for the safe use of the above-mentioned devices lies with the user or operator.

## Safety

### 2.6 Symbols, Bid Signs, and Signal Words



This instruction manual contains a large number of mandatory and warning signs that are intended to provide the user with important information and instructions. These signs are used to identify potential hazards and take appropriate precautions. However, it is important to note that not all characters contained in this instruction manual may be accurate or significant. The use of certain signs depends on various factors, such as the specific model, application or local regulations. It is therefore imperative that the user reads the instructions carefully and identifies the relevant signs that apply to their specific situation. It is recommended to contact the manufacturer or authorized professionals in case of ambiguity for a correct interpretation of the signs. Please note that this owner's manual may not cover all possible hazards or situations. It is the User's responsibility to assess their environment and take appropriate measures to ensure their own safety and the safety of others.



#### Information

This icon indicates important information.



#### Danger

This symbol warns of an imminent danger to the health and life of people. Ignoring such a warning will result in serious injury, possibly fatal.



#### Warning

This symbol warns of situations that can potentially endanger people's health and lives. Ignoring such a warning can lead to serious injury, possibly resulting in death.



#### Suspended load warning

It is forbidden to be under a suspended and/or moving load. This is life-threatening!



#### Warning of entrapment

Risk of entrapment and cuts on hands and fingers, legs and other limbs. Sufficient personal protective equipment must be worn.



#### Warning of counter-rotating rollers

There is a considerable danger due to the risk of pulling in rotating parts. Objects such as clothing or body parts can be severely damaged or injured.



#### Warning of obstacles on the ground

Pay attention to surrounding objects or machine parts on the ground, as there is a risk that you could trip or slip.



#### Warning of sudden loud noise

Watch out for sudden loud noises, as they could affect your hearing. Protective measures such as wearing hearing protection may be necessary to prevent hearing damage.



#### Warning of skin-incompatible or corrosive substances

Attention, there is a risk of skin irritating or injurious substances. Therefore, it is necessary to wear appropriate workwear.



#### Warning about electricity

Only experienced electricians and competent persons may open enclosures and shields marked with this symbol. Before commissioning, all cables must be connected according to the instructions and without damage and the entire system must be able to be switched off with the main switch.



#### Explosive Atmosphere Warning

Warning of an area where explosive atmospheres may occur.



#### Use head protection

This sign indicates that a safety helmet must be worn in a certain area. This can be the case, for example, on construction sites or in factories.



#### Use handguards

This mandatory sign indicates that gloves should be worn in a certain area to ensure protection.



#### Use protective clothing

This sign indicates that protective clothing must be worn in a certain area. This can be the case, for example, on construction sites or in factories.



#### Wear hearing protection

This sign indicates that hearing protection must be worn in a certain area to minimize the risk of hearing damage.



#### Use foot protection

This sign indicates that safety shoes must be worn in a certain area. This can be the case, for example, on construction sites or in factories.

## 2.7 Basic ideas

### 2.7.1 Duty cycle ED in %



- For each engine group, the duty cycle in intermittent mode refers to the period during which the engine can be actively operated before the engine needs a rest period to avoid overheating. The duty cycle is expressed as a percentage. A typical duty cycle value is between 30% and 60%. This means that within a certain period of time, for example 10 minutes, the engine can be on for a maximum of 3 / 6 minutes before it has to be switched off for the rest of the time.
- Unless otherwise specified by the manufacturer, the minimum values for intermittent and short-term operation in relation to the engine group are specified in FEM 9.683 paragraph 5.8.2.2.
- Intermittent operation: In intermittent mode, the motor can be operated at smaller intervals than the specified maximum permissible operating time. This regularly results in smaller breaks. E.g. engine group 1Am, the engine can run for 3 minutes at a time under full load and then has to take a break of 7 minutes.
- Short-term operation: In short-term operation, the engine can be operated without a break for the duration of the maximum permitted operating time. This only applies to the main hub! After that, a much longer break must be taken. Break time is at least 1.5 times the operating time. This corresponds to a break time of at least 22.5 minutes with the same engine group 1Am.

### 2.7.2 Switching cycles s/ & circuits c/h



- The switching backlash s/h for electrical appliances indicates how many times per hour the appliance can set a load in motion without causing damage or impairment of functionality. A switching cycle consists of a complete lifting process (lifting and setting down a load) and is expressed in games/hour.
- In electrical engineering, the circuit c/h or the frequency refers to a complete change of a switching state (start/stop) or pressing/releasing and is also specified per hour. Colloquially, the switch-on also refers to "typing mode".
- A higher switching cycle means that the device has a higher switching frequency and can therefore be switched on and off more often. This can be relevant, for example, for devices such as switches, relays or electronic components that need to be switched frequently. A lower switching cycle, on the other hand, means that the device has a lower switching frequency and can be switched on and off less often. This can be relevant, for example, in equipment such as motors, compressors or heaters, where frequent switching can lead to overload or premature wear.
- The number of possible games or starts per hour depends, among other things, on the duty cycle.
- The backlash s/h and the circuits c/h are therefore important indications to ensure that an electrical appliance functions properly and reliably. It is advisable to follow the manufacturer's instructions.

### 2.7.3 Degrees of protection



- The IP protection class describes an internationally standardised property of electrical equipment against external influences. In particular, it is a question of how well an enclosure is protected against the ingress of foreign bodies and liquids. This classification makes it easy to see whether a device is suitable for a particular purpose. For example, lighting for an uncovered area in the garden, for example, should be able to cope with both moisture and dirt. It is obvious that a lamp for the desk is not the ideal choice here.
- The IP protection classes allow gradations to be displayed. The description of the degree of protection is provided by the IP code. This is made up of two digits. The decisive factor here is the order in which the digits are displayed in the code.
- Protection against foreign objects and contact is expressed with the first digit. And the second digit indicates the moisture protection.
- The abbreviation IP stands for "International Protection" (sometimes also for "Ingress Protection").

## Safety

### 2.7.4 FEM 9,511

#### 2.7.4.1 Engine group



The FEM 9.511 engine group is a standard that specifies specific requirements for electric hoists. It defines different classes based on load capacity and intended use and specifies requirements for design, safety, performance and maintenance.

Table 2 Engine group according to FEM 9.511

Engine group		Intermittent operation		Short-term operation	
FEM	ISO	Games per hour	Switch-ons per hour	Duty cycle in %	Max. operating time in min
1Dm	M1	15	90	15	7,5
1Cm	M2	20	120	20	7,5
1Bm	M3	25	150	25	15
1Am	M4	30	180	30	15
2m	M5	40	240	40	30
3m	M6	50	300	50	30
4m	M7	60	360	60	60
5m	M8	60	360	60	>60

#### 2.7.4.2 Runtime Classes



The runtime class indicates the average running time of an engine per day. An engine is considered to be running when it is in motion. For engines that are not used regularly during the year, the average running time per day is given by the ratio of the annual running time to 250 working days per year.

Table 3 Runtime classes according to FEM 9.511

Runtime class	Mean daily runtime in h	Calculated total runtime in h
V 0,12	$\leq 0,25$	400
V 0,25	$\leq 0,5$	800
V 0,5	$\leq 1$	1.600
V 1	$\leq 2$	3.200
V 2	$\leq 4$	6.300
V 3	$\leq 8$	12.500
V 4	$\leq 16$	25.000
V 5	$> 16$	50.000

#### 2.7.4.3 Load collective



The load spectrum indicates the extent to which an engine or part of it is exposed to its maximum stress or only minor loads. For the exact group classification, the cubic central work  $k$ , related to the load-bearing capacity, is required.

Table 4 Load collective according to FEM 9.511

Load collective	Cubic Mean	Definition
L1 (easy)	$k \leq 0,5$	exceptionally maximum load
L2 (medium)	$0,5 \leq k \leq 0,63$	Frequent maximum load
L3 (difficult)	$0,63 \leq k \leq 0,80$	Often maximum load
L4 (very difficult)	$0,80 \leq k \leq 1,00$	Regular maximum load

#### 2.7.4.4 Classification of engines



With the help of the runtime classes and the load spectrums, the engines are classified into 8 groups. Classification of engines into groups according to the table below allows for the same life expectancy in years for all load spectra and mean daily runtimes. The prerequisite here is that the service life of the individual components depends on the third power of the load.

Table 5 Classification of engines according to FEM 9.511

Load collective	cubic mean	Runtime class							
		V 0,12	V 0,25	V 0,5	V 1	V 2	V 3	V 4	V 5
		Average daily runtime in hours							
		$\leq 0,25$	$\leq 0,5$	$\leq 1$	$\leq 2$	$\leq 4$	$\leq 8$	$\leq 16$	$> 16$
1	$k \leq 0,5$		1Dm	1Cm	1Bm	1Am	2m	3m	4m
2	$0,5 \leq k \leq 0,63$	1Dm	1Cm	1Bm	1Am	2m	3m	4m	5m
3	$0,63 \leq k \leq 0,80$	1Cm	1Bm	1Am	2m	3m	4m	5m	
4	$0,80 \leq k \leq 1,00$	1Bm	1Am	2m	3m	4m	5m		

## 2.8 Hazards according to DIN EN ISO 12100



The following hazards may occur when handling the device.

Please note that the following types of hazards and examples of how to use the device are only excerpts and do not fully cover all possible scenarios. They are only intended as a guide to give you an overview of potential risks. It is important to emphasize that the responsibility for the safe use of the above-mentioned devices lies with the user or operator.

### 2.8.1 Mechanical hazards



Various mechanical hazards can occur when handling lifting equipment. Here are some examples:

- Risk of entrapment: For example, if a crane hook or load is lowered uncontrollably, there is a risk of fingers or other body parts being trapped.
- Crush hazard: When lifting or moving heavy loads, they can be pressed against other objects or people and thus pose a crushing hazard.
- Risk of falling: If hoists are not properly secured or used improperly, the load can fall, which can be dangerous for both the load itself and people nearby.
- Risk of slipping: If the load is not properly secured or the hoist is not properly attached, the load can slip and fall, which can lead to injury.
- Risk of overloading: If a hoist is loaded beyond its maximum load capacity, there is a risk of breakage or damage to the hoist, which can lead to accidents.
- Snagging parts: There is a risk that clothing, tools or other objects could become entangled in the moving parts of the hoist, causing injury.
- Sharp edges or pointed objects: Some loads that are lifted with hoists may contain sharp edges or pointed objects. If these are not properly secured or fall off, there is a risk of cuts or puncture wounds.
- Lack of maintenance: If hoists are not regularly serviced and checked, signs of wear and tear can occur, which can lead to equipment failure and thus pose a hazard.

### 2.8.2 Electronic Hazards



Various electronic hazards can occur when handling lifting equipment. Here are some examples:

- Risk of electric shock: If electrical hoists are not properly insulated or have damaged wires or plugs, there is a risk of electric shock to anyone operating or in the vicinity of the equipment.
- Short-circuit risk: Damaged cables or plugs can lead to a short circuit, which can not only damage the hoist itself, but also cause fires or other electrical disturbances.
- Risk of overheating: When electric hoists are overloaded or run for an extended period of time without adequate cooling, there is a risk of equipment overheating, which can lead to breakdowns or even fires.
- Lack of grounding: If an electric hoist is not properly grounded, it can cause electrostatic discharge, which can be dangerous for both the equipment itself and people nearby.
- Improper use of extension cords: If extension cords are used to drive the hoist, they must comply with the appropriate safety standards and must not be overloaded. Otherwise, there is a risk of short circuits or fires.
- Lack of maintenance: Electrical hoists need regular maintenance and inspection to ensure that all electrical components are working properly and there is no risk of electrical interference.

### 2.8.3 Material and/or substantial hazards



When handling lifting equipment, various hazards can occur due to materials and/or substances. Here are some examples:

- Hazardous or toxic substances: When handling lifting equipment, loads containing hazardous or toxic substances can be transported. If these substances leak or are released, there is a risk of injury or poisoning to people nearby.
- Explosive materials: Transporting explosive materials by lifting equipment can pose a significant hazard. Improper handling or accidental dropping of such loads can lead to explosions and endanger both people and property.
- Heavy or unstable material: Handling heavy or unstable material can lead to increased danger. For example, if a heavy load is not lifted properly or shifts during transport, it can cause accidents and injure people.
- Chemicals: There is a risk of exposure to hazardous fumes, gases, or liquids when using lifting equipment in areas where chemicals are used. This can lead to respiratory problems, skin irritation, or other health problems.
- Asbestos or other harmful substances: When lifting equipment is used in areas where asbestos-containing materials or other harmful substances are present, there is a risk of exposure to these substances. This can lead to serious health problems, especially if proper protective measures are not taken.

### 2.8.4 Acoustic hazards



When handling lifting equipment, various hazards can occur due to acoustic noise. Here are some examples:

- Hearing damage: The operation of lifting equipment can result in significant noise pollution that can damage hearing. Long-term exposure to high noise levels can lead to permanent hearing damage.
- Communication difficulties: Due to the loud noise level, communication and understanding between employees can be difficult. This can lead to misunderstandings or mistakes and compromise security.
- Distraction: Noise can be distracting and affect employee concentration. This can lead to errors in the operation of the hoist or carelessness, which in turn increases the risk of accidents.
- Stress and fatigue: Continuous noise can cause stress and lead to fatigue. This can affect job performance and increase the risk of errors or accidents.
- Interference with warning signals: In a noisy environment, audible warning signals or alarm signals may not be heard, which can lead to a delayed response to potential hazards.

## Safety

### 2.9 Residual risks

#### 2.9.1 General residual risks



When handling the device, different residual risks can occur in different phases of life. Although it is impossible to completely eliminate all risks, residual risks can be minimized by various measures. Here are some ways to avoid residual risks:

- Risk assessment: Conduct a thorough risk assessment to identify potential hazards and assess their likelihood and impact. This allows you to take targeted measures to minimize risks.
- Technical protective measures: Use technical protective measures such as protective devices, emergency stop switches or safety systems to shield or control sources of danger.
- Organizational measures: Implement organizational measures such as clear work instructions, employee training, regular maintenance and inspections, and compliance with safety standards and regulations.
- Personal Protective Equipment (PPE): Provide appropriate PPE and ensure that employees use and maintain it correctly.
- Training and awareness-raising: Regular training for employees to educate them about potential hazards and provide them with the necessary knowledge and risk prevention skills.
- Continuous improvement: Regularly review your security measures and procedures to identify and improve potential vulnerabilities.
- Collaborate with experts: Consult professionals such as safety engineers or occupational health and safety experts to conduct an informed risk assessment and recommend appropriate risk mitigation measures.

It is important that all employees are actively involved in the identification and mitigation of residual risks. Through a holistic safety approach, residual risks can be minimized and a safe workplace can be guaranteed.

#### 2.9.2 General Types of Residual Risks:



There are different types of residual risks that can persist despite all security measures. Here are some examples:

- Accepted risks: These are risks that are considered acceptable due to their low probability or impact. They can occur, for example, when all possible risk mitigation measures have been taken, but a residual risk remains.
- Unforeseen risks: In any situation, there is always some uncertainty and unpredictability. Unforeseen risks can arise when new sources of danger or unexpected events arise for which no specific safety precautions have been taken.
- Human error: Despite training and guidance, human error can occur, whether through negligence, inattention, or misjudgment. This can lead to residual risks, as not all employees always act correctly.
- Technical defects: Although machines and systems are regularly maintained and checked, there is always the risk of technical defects or failures, which can lead to residual risks.
- External influences: External factors such as weather conditions, natural disasters, or human error can create residual risks that are beyond the company's control.
- Change in the work environment: As the work environment or working conditions change, new risks may arise that may require additional protective measures.

It is important to note that residual risks cannot be completely avoided. It is best to take all possible measures to mitigate risk and to continuously train and sensitize employees to keep the residual risk as low as possible.



Assembly, installation and commissioning

### 3.1 Devices and component installations



In order to be able to carry out the mechanical, electronic installation and assembly of the device, it is necessary that the person carrying out the work has experience in the field of power-driven winches. (PLANETA-Hebetechnik GmbH) assumes no liability for problems arising from unauthorized installation and assembly.



Warning of injuries due to assembly errors

Improper installation can lead to serious personal injury and/or property damage! This work may therefore only be carried out by authorised, instructed personnel who are familiar with the operation of the equipment, in compliance with all safety regulations:

- Before starting the work, ensure sufficient freedom of assembly.
- Secure work and hazardous areas.
- Wear protective clothing!
- Be careful with open, sharp-edged components! Injury!
- Pay attention to order and cleanliness in the workplace. Store equipment or attachments and tools that are not needed in such a way that the risk of falling is excluded.
- Assemble components professionally. Comply with the prescribed bolt tightening torques. Improperly fastened components can fall and lead to significant injuries.
- Attach the device only to the intended attachment points.
- Only carry out the installation if all the requirements for the installation site are met.

#### 3.1.1 Device suspension

The electric construction winch is designed to be mounted on a sturdy pipe with a sufficient diameter or optionally on a swivel arm. The device is securely attached to the pipe by means of the hanging bracket. To prevent slipping or unintentional unhooking, the safety hook is latched into the hanging bracket. It is important to note that the operator has the structural responsibility for the correct installation. We recommend using an adapter console when hooking into the swing boom arm to ensure that the unit is firmly fixed and cannot fall off the swing boom arm. This ensures a secure fastening without any potential dangers.

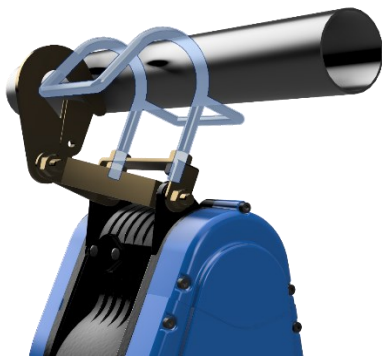

Similar illustrations



In addition, it is possible to install the electric construction winch in a manual monorail chassis.

As a result, a linear movement along a girder is possible and can therefore be regarded as a crane.

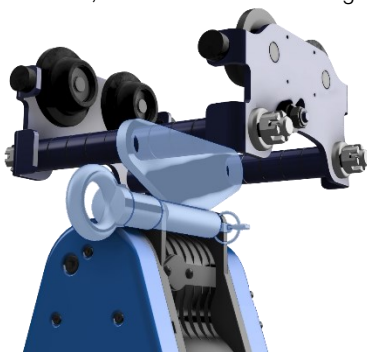

Similar illustrations

In order to install the electric construction winch in a manual monorail chassis, they go through the following steps:

Open one side of the chassis by first loosening the two locking pins with the appropriate tool and unscrew the crown nuts and remove the two washers as well.

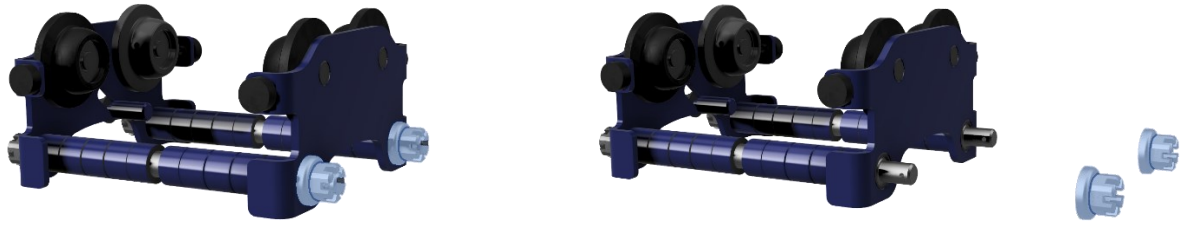

Similar illustrations

Remove the side panel of the landing gear and the corresponding number of spacers. It is essential to make sure that the electric construction winch that will be attached later is in the load centre of gravity of the chassis. In addition, you must make sure that the flange width is set to the correct width of the steel beam to be used and that the wheels have an air gap between 2mm and 3mm to the steel beam so that the chassis does not get stuck or drive unclearly along the beam. As a result, any tolerances of the steel beam can also be absorbed.

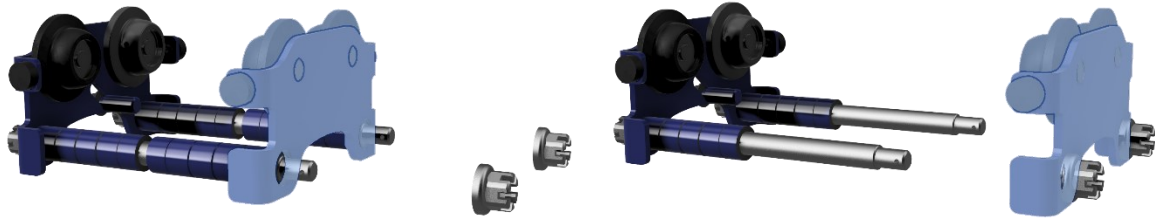

Similar illustrations

Then guide the load beam over the two support bolts of the chassis to the stop and push the same number of spacers as on the opposite side back onto the two support bolts. Again, make sure that the load beam is in the center of gravity of the landing gear.

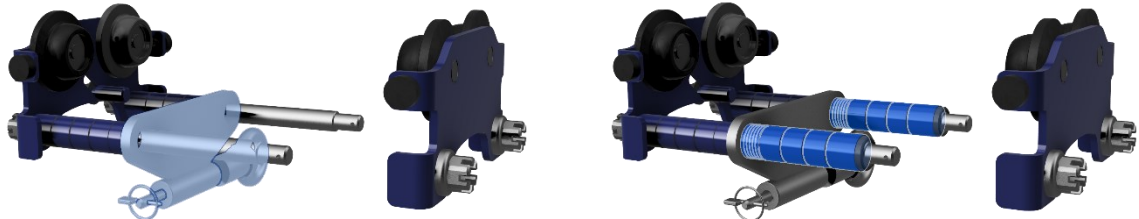

Similar illustrations

In order to mount the chassis on the steel girder, it is possible to place the open chassis from below on the flanges of the beam or, when installed, to slide it over an open side of the steel girder. To illustrate this, the still open chassis is placed on the steel beam from below and then further assembled.



Similar illustrations

In the last step, you can connect your electric construction winch to the permanently installed load beam via the plug-in bolt and then secure it with the folding cotter pin to prevent unintentional loosening.



Similar illustrations

## Assembly, installation and commissioning

### 3.1.2 Power & Control Cables

Please plug the power cord and control cable into the sockets provided by the electric wire rope winch and secure it by tightening the locking ring clockwise. Make sure the cables are properly routed through a holder. Use the safety hook as a strain relief. The power cord has a length of 5m and can be extended by up to 20m if required. A cable with a cross-section of 3.5mm<sup>2</sup> is required for the extension. The control cable is 10m long, and there is the option to use an optional extension cord of another 10m.



Please make sure that the cables do not come into contact with the rope or drum. To minimize the risk of electric shock or damage to the appliance, please ensure that the power plug is properly plugged into a suitable, grounded outlet and in good condition.



Picture similar

## 4 Product description

### 4.1 Area of application



If possible, the units should be installed in a covered area. If installed outdoors, protect the unit from adverse weather conditions such as rain, snow, hail, direct sunlight, dust, etc. In a humid environment, combined with greater temperature fluctuations, the functions are at risk due to condensation formation. Ambient temperature  $-20^{\circ}\text{C}$  /  $+50^{\circ}\text{C}$ , humidity 100% or less, but not under water!



The permissible load of the unit must not be exceeded! Excepted is a possible load test by a recognised competent person before the first commissioning.

#### 4.1.1 Committee of use





In particular, use is not permitted

- for tearing loose stuck loads as well as diagonal pulling if the device cannot align itself to the load.
- Use as for transporting people.
- Use in event and production venues for scenic presentations when persons are under suspended loads.
- Use as a spreader beam in an inbound crane.

### 4.2 Type Shield/ER



A nameplate with product-specific information is attached to the device. The nameplate may differ from the image below.

Standard		
 <p>PLANETA-Hebetechnik GmbH            Resser Str. 17            D-44653 Herne-Wanne            Tel: (+49) 2325 95800            www.planeta-hebetechnik.de            Bitte Handbuch beachten!            Please read manual!</p> 	<b>Typ / Tragfähigkeit</b> (Type / Capacity)	<b>BW-80</b> <b>80 kg</b>
	<b>Serien-Nr. / Baujahr</b> (Serial-No. / Year)	<b>2219839-1</b> <b>2024</b>
	<b>Isol. Kl. / Schutzart</b> (Insi. Class / Protection)	<b>F / IP 44</b>
	<b>Geschw. m/min.</b> (Speed m/min.)	<b>18-30 m/min</b>
	<b>Betriebsspannung</b> (Voltage)	<b>1 Phasen / 230 V / 50 Hz</b>
	<b>Motorleistung</b> (Motor power)	<b>0,8 kW, 25% ED, 1Bm, 4 A</b>
	<b>Seil-Ø / Seillänge</b> (Rope-Ø / Length)	<b>4 mm / 23 m</b>



The following basic information is provided on the nameplate

- name and address of the manufacturer;
- type designation and load capacity;
- serial number and year of manufacture;
- insulation class and degree of protection;
- lifting and lowering speeds;
- Operating voltage;
- engine power, duty cycle FEM and classification;
- dimensions of the rope.

BW

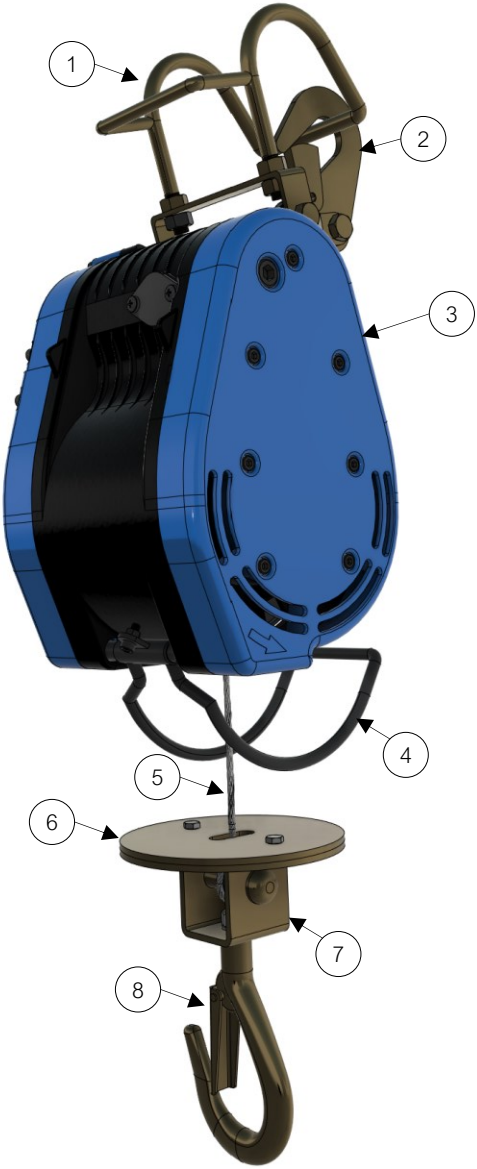

1	Suspension (hanging bracket)
2	Safety hook
3	Case
4	Hub Limit Switch
5	Cable
6	Type Shield
7	Switch disc
8	Load hook with hook jaw lock

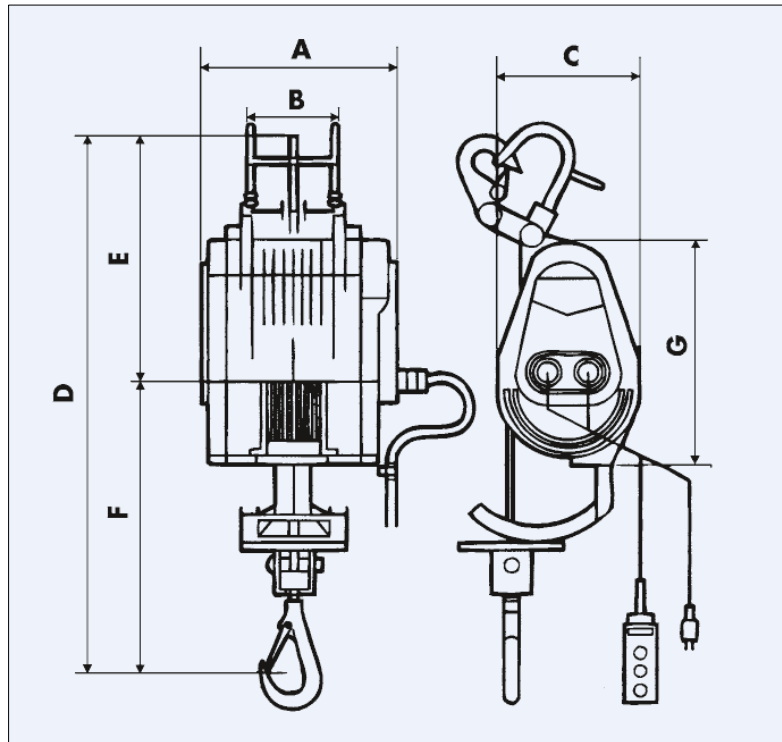

BW 80 / 160 / 230 / 300

TYPE	BW ...	80	160	230	300
Load Capacity (Standard)	kg	80	160	230	300
Velocity 1. Layer	m/min	18	15	9	9
Speed supreme. Layer	m/min	30	22	14	13
Duty cycle ED	%	25% ED at 150 starts/hour			
Power	kW	0,8 kW / 1 PH / 230 V / 50 Hz	1,2 kW / 1 PH / 230 V / 50 Hz	1,3 kW / 1 PH / 230 V / 50 Hz	1,5 kW / 1 PH / 230 V / 50 Hz
FEM grading	-	1Bm			
Degree of protection Motor IP	-	44			
Degree of protection Control	-	65			
Wire rope diameter	mm	102	122	152	176
Wire rope length	m	112	117	144	156
A	mm	35	35	44	48
B	mm	23	23	30	31
C	mm	2,5	2,5	2,5	2,5
D	mm	605	640	640	640
And	mm	266	280	280	280
F	mm	339	360	360	360
G	mm	270	285	285	285
Weight	kg	18	23	24	25

5.1 General information

General requirements for operation with the device:



- Training: The operator should have undergone appropriate training that familiarizes him with the basic knowledge of how to handle the equipment safely. This training can take place, for example, as part of vocational training or training.
- Experience: In addition to training, practical experience in the use of the device is also important. The operator should already have experience and be familiar with the various functions and controls of the device.
- Sense of responsibility: The operator should be aware of his responsibility and observe the safety regulations and measures when operating the equipment. This includes, for example, wearing personal protective equipment and adhering to the prescribed load limits.



It is important to note that the exact requirements and requirements for operating such a device may vary depending on the country and area of use. It is therefore advisable to find out about the rules and regulations in force before operating.



Before operating the device, the following steps should be carried out by the operator:

1. Inspect the device for visible damage or wear. If damage is detected, it should be repaired before use.
2. Checking the working environment for obstacles or hazards that could interfere with the safe operation of the equipment. Obstacles should be removed and sources of danger eliminated.
3. Checking the load to be lifted or pulled for weight, size and stability. The device may only be used for loads for which it is designed.
4. Checking the attachment points of the device to ensure that the device is stable and secure.
5. Verification of the proper lubrication of the steel cable.
6. Checking that the steel cable is running properly to ensure that it enters and exits the device cleanly.
7. Check the lift and lower limit to ensure that the device remains in the correct position and does not continue.
8. Preparation of the device's controls and safety devices to ensure that they are working properly and are easily accessible.
9. Instructing other people working in the vicinity of the equipment about the planned use and the safety precautions that need to be taken.
10. Perform a final visual check of the device and work environment to ensure that everything is ready and that there are no obvious hazards.



Only after these steps have been completed and the operator is sure that the device is working properly and can be used safely, the actual operation can begin.

5.1.1 Overtightening of the rope drum

During the operation of the device, an unobstructed view of the loaded load and the device is required. To prevent the rope drum from overtightening, the device has a stroke limiter in the form of a bracket on the device and a switch plate on the load hook. This mechanism stops the movement of the device as soon as the switch plate pushes the bracket upwards and thus activates the limit switch. Since the shackle is movable, it is crucial to ensure that the distance (S) between the shackle and the construction winch never falls below a certain level, as indicated below.

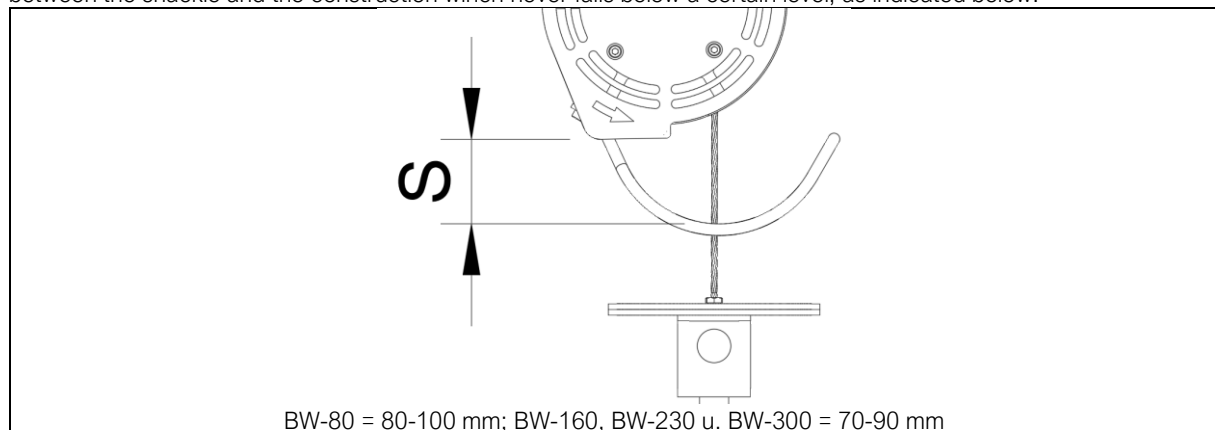

### 5.2 Direction of rotation of the wire rope



In order to avoid damage to the wire rope and the device, it is essential to pay close attention to the correct direction of rotation when winding and unwinding the wire rope. The correct course of the rope is shown as shown in the illustration below. In addition, possible disturbing noises should be taken into account to ensure smooth operation.

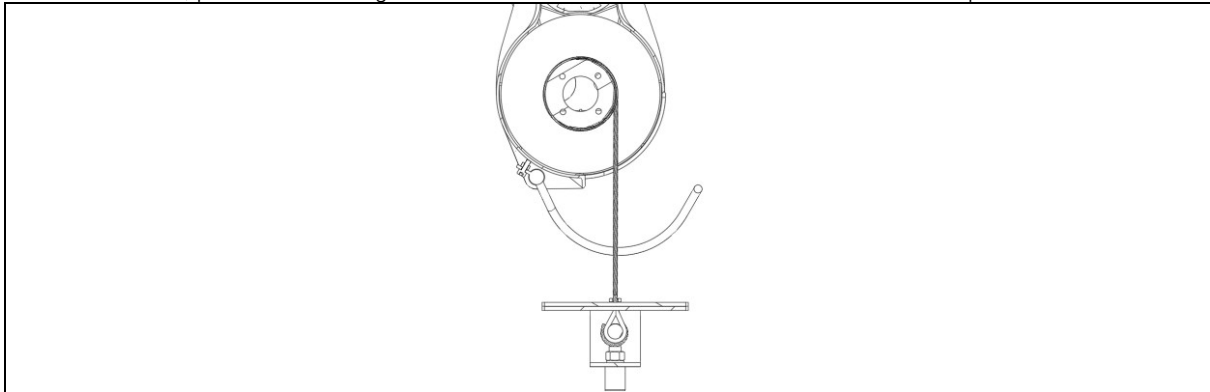

### 5.3 Control Bottle



The movements of the electric construction winch can be carried out with the corresponding controls of the control bottle. To protect against personal injury and property damage, the control switch is equipped with an emergency stop device. The emergency stop device must be checked regularly to ensure that it is working.



Please note that the device only has one speed setting and does not offer any additional fine stroke. Therefore, special care must be taken when lifting and attaching a load to ensure the necessary safety. The device must not be positioned slowly by repeatedly pressing the switch buttons (tap mode), as this may cause damage. Make sure that lifting movements are carried out only with properly attached and sufficiently heavy loads. This prevents the rope from winding up on one side and potentially being damaged. When lowering, be sure to pay attention to the safety windings that must remain on the rope drum.



Certain work and activities are not permitted when handling the device, as they may be associated with dangers to life and limb as well as cause permanent damage to the device, e.g.:

- Unsafe handling of the load (e.g. penduluming).
- Guiding attached loads across people.
- Pull or tow attached loads at an angle.
- Tear loose stuck or jammed loads.
- Exceeding the maximum permissible load and permissible load dimensions.
- Leave suspended loads unattended.
- Deflect load-bearing equipment over edges.
- Use the carrying equipment as a carrying sling.
- Allow loads to fall into the limp load-bearing device.
- improperly load controls.
- Operate controls improperly frequently (typing mode).
- Carriage of persons is not permitted.
- Manipulation of mechanical and electrical equipment.

### 6.1 General information about transport



The device should be transported correctly to avoid accidents and damage. Here are the steps to follow before, during and after transporting the device:

#### 6.1.1 Before transport:

1. Inspect the device for visible damage or wear.
2. Make sure that the device has been properly maintained and that all safety precautions are in place.
3. Check the load capacity of the device and make sure it is suitable for the intended transport.
4. Make sure all instruction manuals and safety instructions are available.

#### 6.1.2 During transport:

1. Use appropriate means of transport, such as forklifts or cranes, to move the equipment.
2. Make sure the device is properly secured to prevent it from slipping or falling during transport.
3. Keep the device in a stable position and avoid abrupt movements or vibrations.
4. Make sure that no people are standing near the device or could be in danger.

#### 6.1.3 After transport:

1. Check the device again for any visible damage or wear that may have occurred during transit.
2. Perform a thorough inspection to ensure that all parts and components are intact.
3. Follow maintenance instructions according to local and legal regulations to keep the device in good condition.
4. Store the device in a suitable place away from weather conditions and damage.

It is important to follow these steps carefully to ensure safety when transporting equipment and to avoid possible damage or accidents.

## 7 Maintenance

### 7.1 General information



Persons responsible for inspection and maintenance of the unit should have appropriate expertise and experience. As a rule, these are qualified specialists, such as mechanical engineers, electrical technicians or mechanics.



When inspecting and maintaining the unit, it is essential to ensure compliance with applicable safety regulations. This includes, among other things:

- Regular inspection of the equipment for wear, damage or malfunctions.
- Checking the load-bearing capacity and load-bearing capacity of the equipment.
- Checking the safety devices, such as emergency stop switches or overload fuses.
- Checking the electrical connections and wiring.
- Visual inspection of ropes, chains or belts for damage or wear.
- Lubrication and maintenance of moving parts.
- Documentation of the inspections and maintenance carried out.



It is important that inspection and maintenance is carried out by qualified personnel to ensure the safety of the equipment and the health of the users.

### 7.2 Maintenance



Maintenance is the umbrella term for all work steps that are intended to ensure the functionality of machines and systems. Maintenance therefore includes inspection, servicing and repair. This also includes work steps such as improvement and weak point analysis. The entire maintenance process is regulated by DIN 31051.

#### 7.2.1 Inspection



Inspection is a part of maintenance and refers to the regular inspection of a machine to ensure its proper condition, functionality and safety. Components, assemblies and equipment are examined for signs of wear, visual inspections are carried out and actual values are compared with target values. The goal is to determine the progress of wear and tear and determine the reasons for it. The inspection, also known as periodic testing, is carried out by a qualified person at predefined intervals, depending on environmental influences and machine utilization. The results of the inspection have consequences for the further handling and use of the plant.

#### 7.2.2 Maintenance



During maintenance, work takes place on the machine. The target state is restored. Maintenance work is intended to delay the progression of wear and tear or, in the best case, to prevent it altogether. All actions taken should be recorded in a protocol. Regularly carried out and documented maintenance maintains the warranty claim and increases the resale value of a machine or system. Normally, the interval between two maintenance is one year.

#### 7.2.3 Restoration



If a defective component is discovered and replaced during maintenance work, this is a repair measure. The target state, i.e. perfect, functional operating behaviour, is restored. Through inspections and maintenance, the machine is observed, cared for and wear is inhibited. After a certain period of time, however, even when a machine is used as intended, wear-and-tear damage often occurs. Repairs must be carried out immediately after the damage has been discovered. The defective parts are either repaired or replaced, depending on the situation and costs. Entire assemblies can also be replaced. At the end of the day, operability and functional safety must be restored. All repair measures must also be entered in the maintenance log.

#### 7.2.4 Spares



Damaged components that need to be replaced due to wear and tear or faulty conditions during maintenance or repair should be replaced by a qualified person. Only original fasteners, spare parts and accessories according to the manufacturer's spare parts list are to be used. Only these parts are covered by the warranty. Any liability of the manufacturer is excluded for damage caused by the use of non-original parts and accessories.



Incorrect or faulty spare parts can lead to damage, malfunction or total failure of the device.



If you have any questions or order spare parts, please have the factory or order number (test book, load plate on the device) ready. Providing this data ensures that you receive the correct information or the required spare parts.



### 7.3 Inspection and maintenance interval



The intervals for inspections and maintenance of the device depend on the duration of use and the operational stress. As a rule, short, regular inspections and maintenance are recommended to ensure the proper functioning of the device and to detect possible problems at an early stage. For some equipment, an annual inspection may be sufficient, while others may require maintenance every six months or even more often. National law and regulations must be complied with in any case. In addition, regular maintenance such as lubricating moving parts, checking wear parts, and cleaning the device should also be performed. The following information is provided as a guideline.

Table 6 Types of use of the device

Types of use	
Normal use / operation:	Use with randomly distributed loads within the nominal load limit or with uniform loads below 65% of the maximum load capacity for a maximum of 15% of the operating time.
Difficult use / operation:	Application in which the equipment is operated within the nominal load limit and which goes beyond normal use.
Tough use / operation:	Application in which the equipment is operated under normal or difficult conditions with abnormal operating conditions.

Table 7 Intervals depending on the type of use of the device

Intervals depending on the type of use	
Daily Inspection:	by the operator or other designated persons prior to daily operation.
Frequent Inspection:	by the operator or other specified persons at intervals determined by the following criteria: <ul style="list-style-type: none"> <li>• Normal use: monthly</li> <li>• Difficult operation: weekly to monthly</li> <li>• Hard work: daily to weekly</li> </ul> There is no need to keep records.
Periodic inspection:	by designated persons at intervals determined by the following criteria: <ul style="list-style-type: none"> <li>• Normal use: annually</li> <li>• Difficult assignment: every six months</li> <li>• Hard work: quarterly</li> </ul> Records shall be kept for the continuous assessment of the condition of the equipment.

## Maintenance

### 7.4 Inspection & Maintenance Plan



As part of our efforts to ensure the safety and functionality of the device, we would like to provide you with important information about the minimum test criteria for the periodic tests. These test criteria are intended as a guideline and should be carefully considered during each periodic audit to minimize potential risks.

#### 7.4.1 Visual inspections

o.B: without complaint B: Complaints n.r.: not relevant

Document Type / Component	o.B.	B.*	n.r	Remark / Deficiency
Instruction manual(s)				
Declaration of Conformity(s)				
Risk assessment(s)				
Test report(s) or test book				
Markings (nameplate)				
Enclosures & Protective Covers				
Bearings				
Fasteners and screws				
Control Bottle				
Steel cable				
Hoisting drum				
Stroke and lowering limiters				
Suspension (hanging bracket and safety hooks)				
Load hook				
Braking system and brake elements				

#### 7.4.2 Functional tests

o.B: without complaint B: Complaints n.r.: not relevant

Component / Type of Functional Test	o.B.	B.*	n.r	Remark / Deficiency
Control Bottle and Controls				
Function without load				
Function under Nominal Load (Maximum Load)				
Function under overload (overload protection test) *				

\*applies only to devices that are equipped with an overload protection.

#### 7.4.3 Lubrication



All mechanically moving parts should be thinly coated with a creeping lubricant on a regular basis. Gearboxes and transmission components should also be regularly coated with a lubricant. In this case, we recommend the use of an EP2 class lubricant. Exception: Brake parts must not be lubricated! When not in use, hang the device in a dry place. Please note that only if original spare parts are used can a safe and flawless operation be guaranteed. If you would like to have the device checked or repaired within the scope of the warranty, we ask you to send the device in its assembled condition. Unfortunately, we can no longer recognize warranty claims when disassembled devices are sent in

Table 8 Lubricant

Delivery company	Designation
FUCHS LUBRITECH	Stabylan 2001
FUCHS LUBRITECH	Stabylan 5006
FUCHS LUBRITECH	Ceplattyn 300 (Graphitpaste)
Klüber Lubrication München KG	Klüberoil CA 1-460
Klüber Lubrication München KG	Klüberoil 4UH 1-1500
CASTROL	Optimol Viscogen KL300

7.5 Replacement of components and materials

7.5.1 Wire rope change



Pass the new end of the rope through the limit switch bracket and insert it into the hole in the drum base. Secure with the grub screw. Pay attention to the direction of lifting! Then wind the rope onto the drum using the lifting movement. The rope turns must lie neatly next to each other.

When replacing the rope, the following must be observed:

Depending on the design of the hoist rope and the hook, the rope thimble must be released from the hook (see picture), the rope must be completely unwound and removed from the drum hole. When winding the new rope, the reel axis must be kept parallel to the drum axis so that the rope can be wound up without twisting.

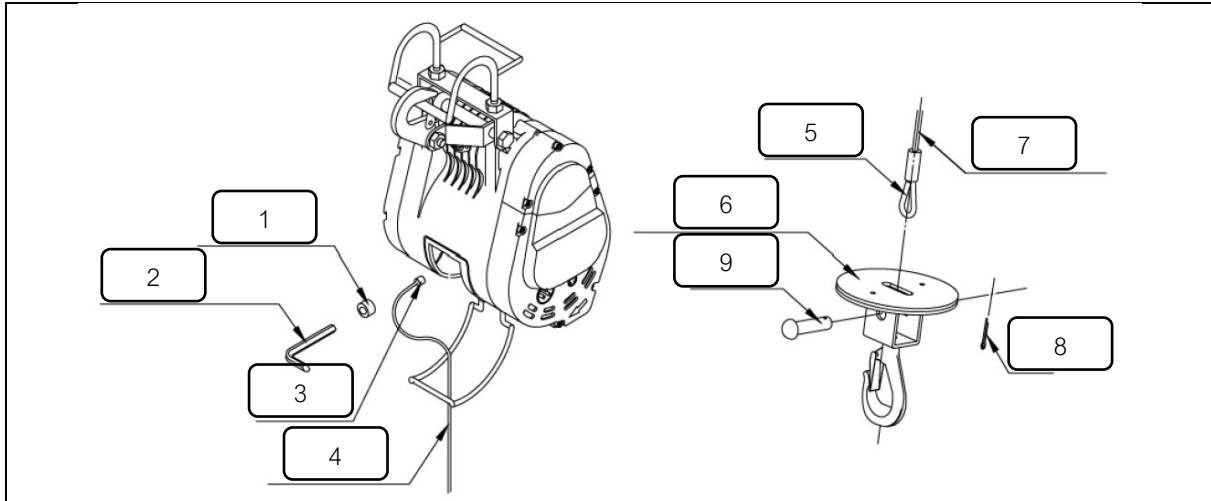

1	Screw
2	Hex wrench
3	Clamp
4	Cable
5	Rope loop
6	Load hook
7	Cable
8	Pin
	Sleeve

7.5.2 Replacing the carbon brushes



The carbon brushes should be checked every 100 hours of use. It is important to keep an eye on their length, as sinking below 7.5 mm will require immediate replacement to avoid serious damage to the engine. It is advisable to order and stock spare parts in a timely manner to avoid business interruptions. When replacing the brushes, make sure to open the protective cap and insert the O-ring properly. It is recommended to always replace both carbon brushes at the same time, even if only one is worn, to ensure optimal performance.

7.5.3 Oil change



Before commissioning a new construction winch or a winch that has not been used for a long time, it is crucial to ensure that the gearbox is filled with the correct amount and quality of oil. For the BW-80 winch, the required amount of oil is 100 cc, while the special models BW-160, BW-230 and BW-300 require 250 cc. The first filling was carried out at the factory. A first oil change should be carried out after about 350 hours of operation. Subsequently, the oil should be changed at least once a year, with the frequency of the oil change depending on the period of use. To be able to change the oil, all you have to do is remove the screw (see picture).

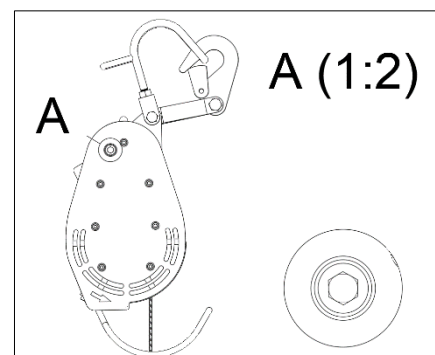

## 8 Troubleshooting and fault rectification

### 8.1 Faults

If there is a malfunction during use with the unit, the following steps should be taken:



1. Immediately stop use and check the cause: Stop use immediately to avoid further damage or accidents. Examine the unit carefully to identify the cause of the malfunction. Check the gears, chain and other components for damage, wear or blockages.
2. Remedy the malfunction and restore functionality: Depending on the type of malfunction, various measures may be necessary. For example, remove foreign objects or dirt that are blocking the unit. If there is wear or damage, parts may need to be replaced or repaired. In the case of serious malfunctions, you should call in a specialist to carry out the repair. Make sure that the unit functions properly after the malfunction has been corrected. Re-check all components to make sure they are properly assembled and in good condition.
3. Safety check: Before using the unit again, carry out a safety check to ensure that it is safe and reliable. Check the load bearing capacity, fixing points and all safety devices.



It is important that only trained personnel repair or perform maintenance on the unit to prevent further damage or accidents.

### 8.2 Causes of malfunctions and measures



The table below provides a summary of the main disorders and checkpoints for each symptom. Please note that this is not a comprehensive list of all possible faults.

Table 9 Causes of malfunctions and measures

Disturbance	Possible Cause of Error	Test point(s)
No reaction	No electricity	Check the power supply
	Defective power connection	Repairing the plug
	Blown engine	Engine Replacement
	Blown Engine Thermal Protector	Engine Replacement
	Abnormal Voltage Drop	Check for correct voltage
Lifting speed that is too slow	Overload	Reduce load
	Abnormal Voltage Drop	Check for correct voltage
		Check the power supply cable
Electrical leakage or shock	Blown motor due to overload	Engine Replacement
	Carbon brushes rubbed off	Replace brushes and clean motor
	Water has entered the motor or control system	Dry
		Replacing the motor or controller
Braking distance longer than 1.5% of the rope length	Brake pad worn	Brake Pad Replacement
	Expansion joint blown out	Compensator Replacement
	Voltage too high	Check for correct voltage
Loud noise in the gearbox	Too little oil due to leakage	Oil Seal Replacement
		Top up with enough oil
	Damage to the gearbox	Repairing the gearbox

## 9 Decommissioning and disposal

---

### 9.1 Decommissioning and disposal



The device should be taken out of service and/or disposed of if it stops working or is irreparably damaged. This can also be the case if the device is outdated and needs to be replaced with a newer version. It is important that disposal is carried out in accordance with local regulations and laws to avoid environmental damage. In some cases, devices can also be recycled or reused instead of simply throwing them away. When not in use, store the device in a dry place. Please note that only if original spare parts are used can a safe and flawless operation be guaranteed. If you would like to have the device checked or repaired as part of the warranty, we ask you to send the device in its assembled condition. Unfortunately, we can no longer recognise warranty claims when disassembled devices are sent in. Please note that electronic waste, electronic components, lubricants and other auxiliary materials are subject to hazardous waste treatment and may therefore only be disposed of by approved specialist companies. National disposal regulations must be observed with regard to the environmentally sound disposal of the machine. Further information can be obtained from the relevant local authority.

## 10.1 Declaration of Conformity of a complete Machine



# EU DECLARATION OF CONFORMITY (Original)

*Within the meaning of Regulation (EU) 2023/1230 according to Annex V, Part A and Annex VI Internal Production Control (Module A)*

We hereby declare,  
PLANETA-Hebetechnik GmbH on own responsibility,  
that the machine, with the following information, complies with the relevant essential health and safety requirements of EU Regulation 2023/123 and the relevant harmonised standards in its design and design as well as in the version placed on the market by us.

We confirm that the special technical documentation for this complete machine has been prepared in accordance with Annex V Part A. These documents will be made available to the market surveillance authorities via our documentation department upon request.

The declaration of conformity loses its validity if changes or additions are made to the machine that have not been agreed with us. Likewise, the declaration expires if the machine is not used in accordance with the use cases described in the operating instructions or if the prescribed periodic inspections are not carried out. It is important to note that this declaration of conformity does not include any assurance of properties. Therefore, the safety instructions and instructions of the product must be carefully observed.

The product below is considered a complete machine if all the components necessary for operation are in place and the product can be operated properly without any additional modifications or adjustments after assembly at the point of use. Furthermore, the product must meet all relevant safety requirements and be provided with the necessary compliance documents as well as a mark confirming compliance with the applicable legal requirements. If this is not the case, the declaration of conformity loses its validity.

### Machine Information:

Machines / Product Type:	Electric construction winch
Machines / Product name:	BW
Function:	Vertical moving of loads
Serial number:	2300001-1 ... 29999999-99 / 6000000001-6999999999
Carrying capacity:	80kg ... 300kg
Year of construction:	2024

The following legal regulations and regulations have been taken into account and complied with:

Regulation (EU) 2023/1230 L165/1	Machinery Product Ordinance
Regulation (EC) No 1907/2006 L136/3	REACH Regulation
Directive 2014/53/EU 02014L0053	Radio Channeling guideline
Directive 2014/30/EU	EMC Directive*
Directive 2014/35/EU	Low Voltage Directive**
Directive 2012/19/EU L197/38	WEEE Directive*
Directive 94/62/EC 01994L0062	Packaging Guideline
Directive 2011-65/EU L174/88	RoHS Directive*

\*The listed legal provisions only apply if the above-mentioned machine contains electronic or radio-capable components.

\*\* Directive 2014/35/EU is complied with in accordance with Chapter 1.5.1 of Regulation (EU) 2023/1230 with regard to its protection objectives.

The following harmonised standards have been taken into account and complied with:

DIN EN ISO 12100:2011-03	Safety of machinery -
BS EN ISO 12100:2011-03	General Design Principles Risk Assessment and Risk Mitigation
DIN EN ISO 20607:2019-10	Safety of machinery -
BS EN ISO 20607:2019-10	Operating Instructions General Design Principles

Place and date on which the declaration of conformity was issued:

Resser Str. 17 | 44653 Herne | Germany, 01.08.2024

On behalf of Philipp J. Hadem  
(CE Coordinator)

## 10.2 Declaration of Conformity of an incomplete Machine

**EU DECLARATION OF INCORPORATION(Original)**

*Within the meaning of Regulation (EU) 2023/1230 in accordance with Annex V, Part B and Annex VI Internal Production Control (Module A)*

We hereby declare,  
PLANETA-Hebetechnik GmbH on own responsibility,  
that the machine, with the following information, complies with the relevant essential health and safety requirements of EU Regulation 2023/123 and the relevant harmonised standards in its design and design as well as in the version placed on the market by us.

We confirm that the special technical documentation for this incomplete machine has been prepared in accordance with Annex V Part B. These documents will be made available to the market surveillance authorities via our documentation department upon request.

The declaration of conformity loses its validity if changes or additions are made to the machine that have not been agreed with us. Likewise, the declaration expires if the machine is not used in accordance with the use cases described in the operating instructions or if the prescribed periodic inspections are not carried out. It is important to note that this declaration of conformity does not include any assurance of properties. Therefore, the safety instructions and instructions of the product must be carefully observed.

The product below is considered an incomplete machine according to the Machinery Directive 2006/42/EC and the Machinery Regulation 2023/123 if it does not contain all the components necessary for operation and requires additional modifications or adjustments after assembly at the point of use in order to be able to operate properly. In addition, the product is considered incomplete if it does not meet all relevant safety requirements and does not have the necessary CE marking, which certifies compliance with the applicable legal requirements.

## Machine Information:

Machines / Product Type:	Electric construction winch
Machines / Product name:	BW
Function:	Vertical moving of loads
Serial number:	2300001-1 ... 29999999-99 / 6000000001-6999999999
Carrying capacity:	80kg ... 300kg
Year of construction:	2024

The following legal regulations and regulations have been taken into account and complied with:

Regulation (EU) 2023/1230 L165/1	Machinery Product Ordinance
Regulation (EC) No 1907/2006 L136/3	REACH Regulation
Directive 2014/53/EU 02014L0053	Radio Channeling guideline
Directive 2014/30/EU	EMC Directive*
Directive 2014/35/EU	Low Voltage Directive**
Directive 2012/19/EU L197/38	WEEE Directive*
Directive 94/62/EC 01994L0062	Packaging Guideline
Directive 2011-65/EU L174/88	RoHS Directive*

\*The listed legal provisions only apply if the above-mentioned machine contains electronic or radio-capable components.

\*\* Directive 2014/35/EU is complied with in accordance with Chapter 1.5.1 of Regulation (EU) 2023/1230 with regard to its protection objectives.

The following harmonised standards have been taken into account and complied with:

DIN EN ISO 12100:2011-03	Safety of machinery -
BS EN ISO 12100:2011-03	General Design Principles Risk Assessment and Risk Mitigation
DIN EN ISO 20607:2019-10	Safety of machinery –
BS EN ISO 20607:2019-10	Operating Instructions General Design Principles

The commissioning of the incomplete machine will be prohibited until the incomplete machine complies with the provisions of EU Regulation 2023/123 and the EC declaration of conformity according to Annex V Part A is available.

Place and date on which the declaration of conformity was issued:

Resser Str. 17 | 44653 Herne | Germany, 01.08.2024



On behalf of Philipp J. Hadem  
(CE Coordinator)



10.3 Circuit diagram

10.4 Wiring diagram (standard)

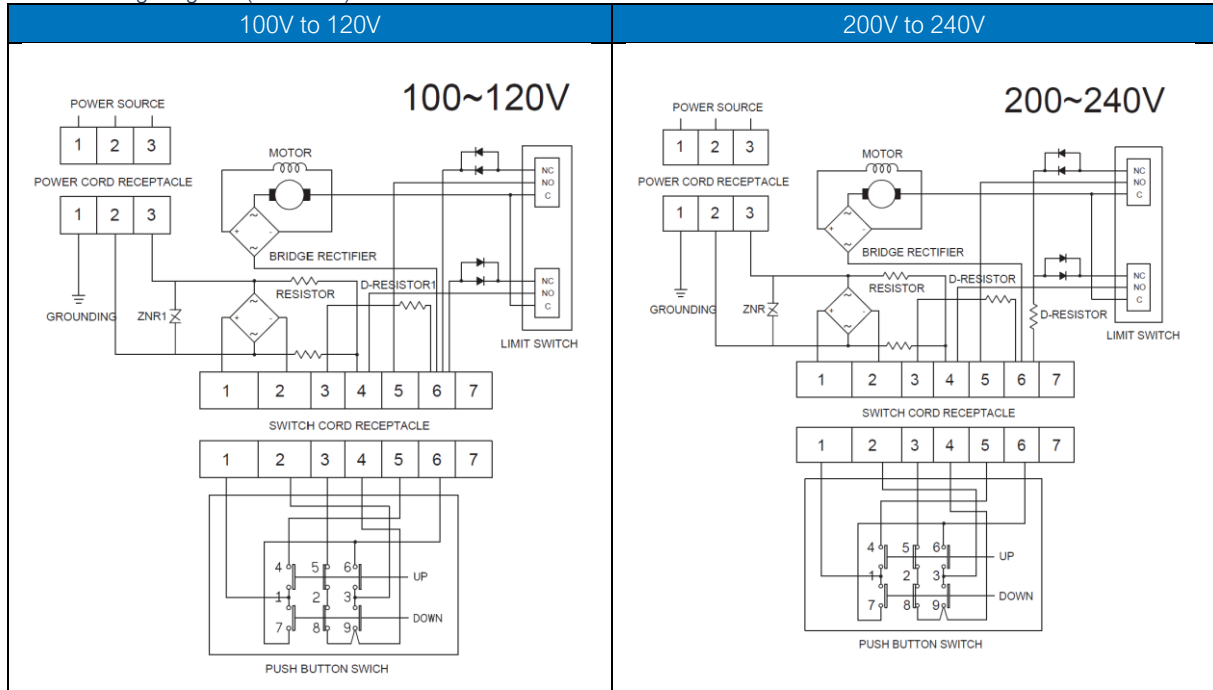

10.5 Circuit diagram (with EMERGENCY STOP)

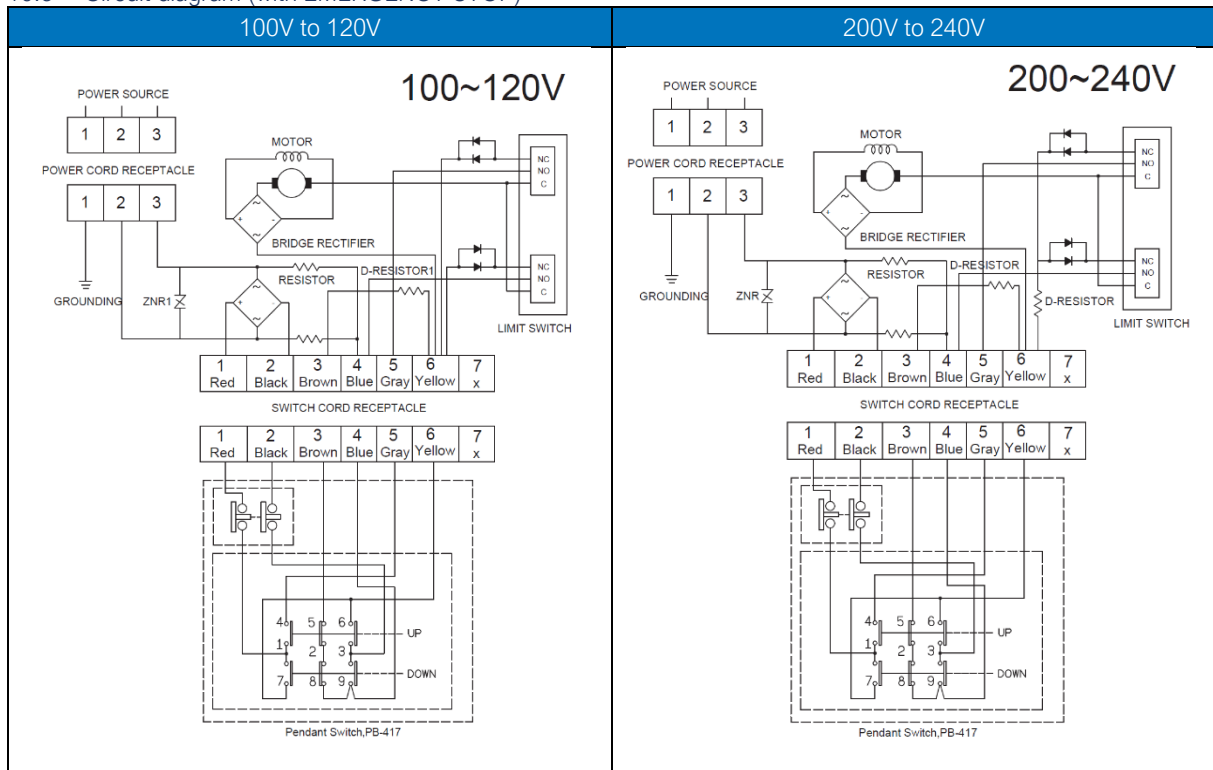

Pos.	Set Description	Quantity
1.	Rear gearbox cover, blue	1
2.	Pawl	1
3.	Brake set	1
4.	1. Gang	1
5.	3. Gang	1
6.	4. Gang	1
7.	Housing incl. gasket and bearings	1
8.	The traghak complete	1
9.	Abrasive carbon holder complete	1
10.	Abrasive carbon	1
11.	Limit shutdown to complete	1
12.	Drahtseil 4,8 mm x 31 m	1
13.	Load hook complete	1
14.	Stator	1
15.	Cooling cover	1
16.	Rotor	1
17.	Limit shutdown from complete	1
18.	Return shaft set	1
19.	Drive shaft	1
20.	Drum set	1
21.	Controller	1
21.1	Resistance	1
21.2	Limit switch	1
21.3	Diode MP-5010	1
22.	Rubber seal	1
23.	Control Cover Complete	1
24.	Power cord 5m complete	1
25.	Service bottle incl. 10m cable	1

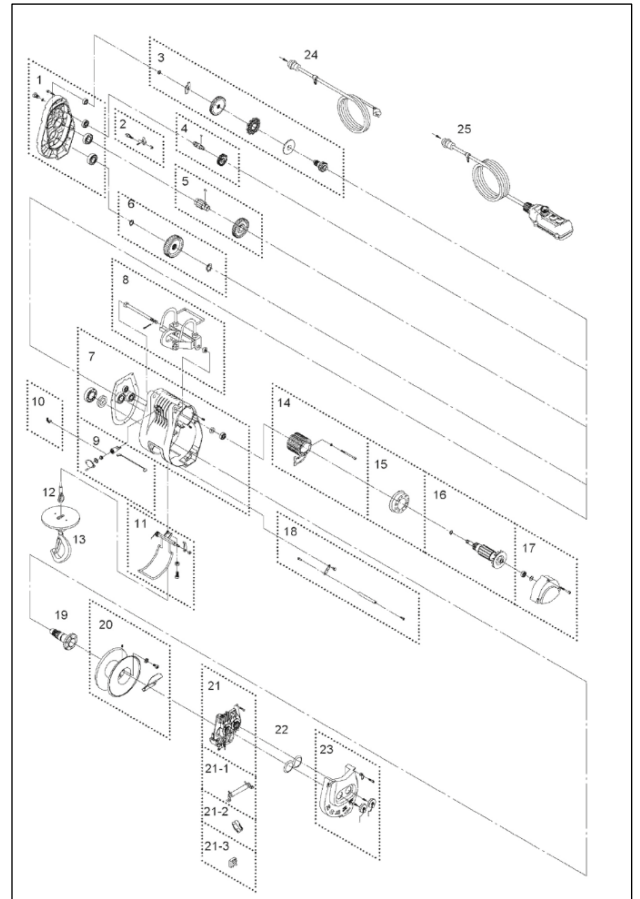









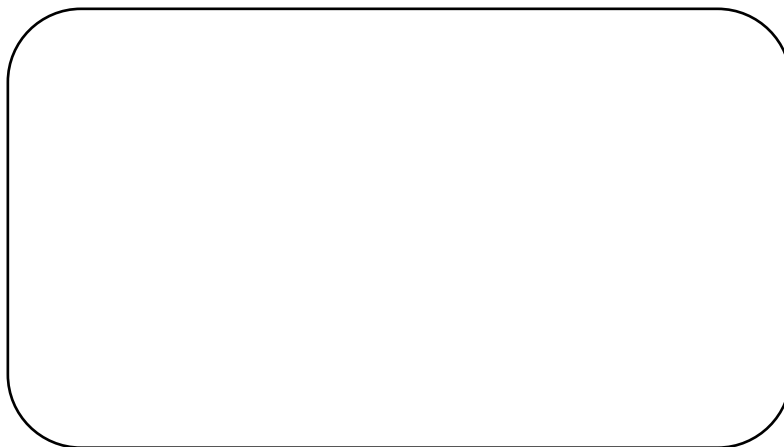

Subject to change without prior notice! Copyright © (PLANETA-Hebetechnik GmbH) is constantly striving to expand and improve its products, which also applies to the relevant upstream suppliers. Although we have made every effort to ensure that this manual with all its technical information is as complete and correct as possible, we cannot guarantee the correctness and completeness of the information, as not all information from the upstream suppliers is always available at the time of going to press. Design and specification are subject to change without notice. The use of an installed and supplied part today does not guarantee its availability in the very future. We therefore ask you, the customer, to check the availability and conformity of any part that is critical to you in order to stock up appropriately at the time of delivery if necessary.