

PTM- & GTM-Trolleys

The manual trolleys are moved against the load by pressing; on the reel chain trolley, pulling the endless manual chain moves the goods to be transported to the right or left. The PREMIUM PRO hoists with the same load bearing capacity can be attached to and removed from the longitudinal eye without problems using the hook, which compensates for swinging loads. The manual chains are galvanised to protect the user and for a long service life. Installation is performed by sliding onto the open beam.

Robust side plates

Balanced load distribution on four wheels thanks to self-adjusting links around the bolt axis! Four safety tabs on the ends of the side plates are used as wheel-break supports, rail cleaners and fall protection.

Ball bearings

The cast iron wheels are quiet and safe due to the lifetime lubricated, sealed ball bearings. They ensure that the trolleys run smoothly and safely.

Large flange adjustability

PTM- & GTM-trolleys are adjustable for various beam sizes by simply changing the number of spacers. The standard bolts are for small flange widths, size 2 bolts allow the use on wider flanges like high HE-B-girders with 300 mm widths (for special beams: additional charge on request). A starting buffer can be supplied as an option.

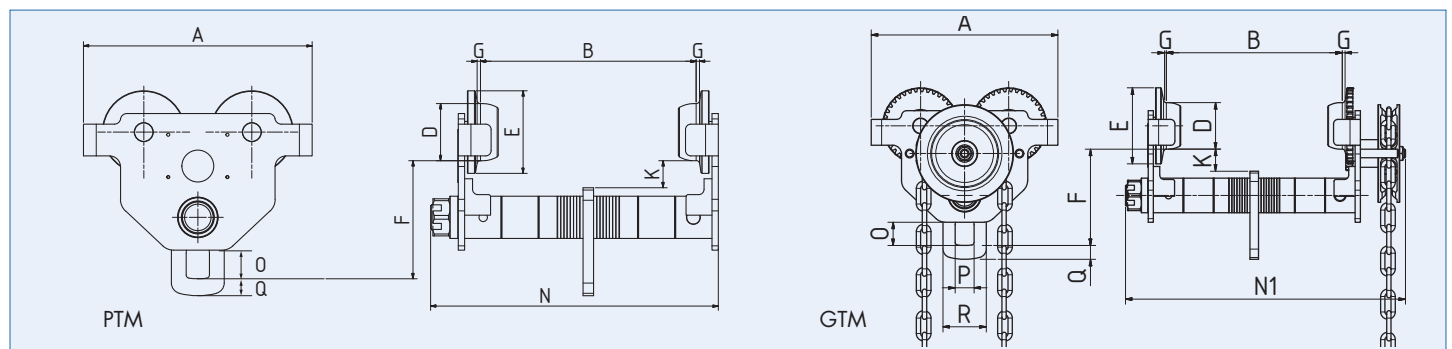
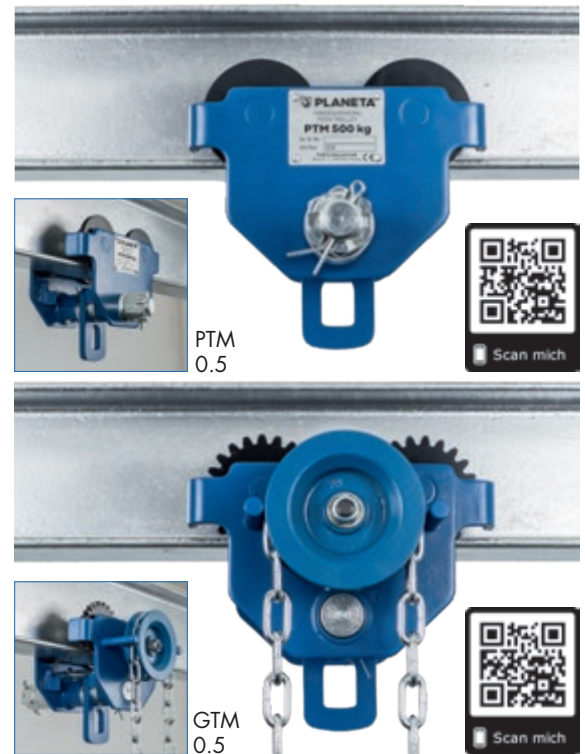

TYPE	PTM ...	0.5	1	2	3	5	10	-
TYPE	GTM ...	0.5	1	2	3	5	10	20
Capacity	kg	500	1,000	2,000	3,000	5,000	10,000	20,000
Flange width B min. – max. PTM / GTM	mm	50 – 203 / 64 – 203	64 – 203	88 – 203	100 – 203	114 – 203	124 – 203	136 – 203
Min. curve radius	m	0.8	0.9	1	1.2	1.3	1.7	2.8
Hand chain operation length GTM	m	2.5	2.5	2.5	2.5	2.5	2.5	2.5
Reel path for 1 m path GTM	m	3	3.6	4.7	5.7	6.3	8	10.6
A (Dimensions)	mm	200	236	276	326	380	426	522
D	mm	54	67	80	100	109	133	170
E	mm	78	96	110	133.5	145	176	227.5
F	mm	111	134	162.5	186	224	198	248
G	mm	3	3	3	4	4.5	4.5	4
K	mm	25	34	28	32	38	50	58
N	mm	281	292	305	321	327.5	341	–
N1	mm	339	351	362	375	386	410	466
O	mm	30	38	55	66	77	108	113
P	mm	22	30	37	42	50	86	106
Q	mm	16	20	25	26.5	34	48	57
R	mm	50	70	90	100	120	–	–
Net weight PTM	kg	7	10.5	17.5	27	41	74	–
Net weight GTM	kg	10.2	14.5	21.5	31	46	79	173
PTM	Order No.	G20000	G20001	G20002	G20003	G20004	G20005	–
GTM with 2.5 m operation length	Order No.	G20006	G20007	G20008	G20009	G20010	G20011	G20012
Larger flange width min. – max.	mm	64 – 305	64 – 305	88 – 305	100 – 305	114 – 305	124 – 305	136 – 305
	Order No.	G20013	G20014	G20015	G20016	G20018	G20019	G20047
Add. operator length hand chain per m	Order No.	G20017	G20017	G20017	G20017	G20017	G20017	G20017

More capacities on request!

The manual trolleys shown are designed for use with manual hoists.