

Spring balancer TCN

The devices are characterised by high quality and a long service life. The suspended tool is moved into a weightless condition with the entire cable extended, then after being released, it is retracted back to the set working load.

Productive

Spring balancers make the suspended load almost weightless. A tool is suspended at the workplace. Its load-bearing range covers the weight of the tool plus that of the connecting cable or hose.

The spring is then set to the precise total weight using an Allen key - from which point the tool can be moved up and down effortlessly. Work equipment and tools attached to spring balancers are quicker to pick up and to „put back down“.

As well as productivity, housekeeping and cleanliness at the workplace are improved substantially.

Applications

For electrical and pneumatic tools, grinders, polishing machines, impact wrenches, riveting machines, spot welding tongs, crane control units, etc.

Features

- Capacity from 4 kg to 70 kg
- Closed and ribbed aluminium version with stainless steel cable
- Precise setting of load-carrying area with a worm screw
- Safety mounting
- Fall protection prevents load from falling if spring breaks (load-bearing capacity > 3 kg)
- Rotary top mounting with safety hook
- Blocking fixture to secure and release the load at the desired height
- Adjustable extension limit
- Tapered rotary drum with ball bearing
- Low-friction cable guide
- Rotary hook with ball bearing
- Spring pack



Classification ⚠ II 2GD c II T 85°C (T6)

TYPE TCN	Capacity kg	Rope length m	Rope-Ø mm	Weight kg	Dimensions in mm								Order No.
					A	B	C	D	E	F	G	H	
9354EX	4 – 7	2	3	4.94	196	528	140	11	10	18	551	11	G30130
9355EX	7 – 10	2	3	5.3	196	528	140	11	10	18	551	11	G30131
9356EX	10 – 14	2	3	5.67	196	528	140	11	10	18	551	11	G30132
9357EX	14 – 18	2	3	6.26	196	528	140	11	10	18	551	11	G30133
9358EX	18 – 22	2	3	5.89	196	528	140	11	10	18	551	11	G30134
9359EX	22 – 25	2	3	6.53	196	528	140	11	10	18	551	11	G30135
9502EX	20 – 30	2.1	3	12.6	251	615	227	14.5	15	18	645	15	G30150
9503EX	30 – 40	2.1	3	15.2	251	615	227	14.5	15	18	645	15	G30151
9504EX	40 – 50	2.1	3	15.5	251	615	227	14.5	15	18	645	15	G30152
9505EX	50 – 60	2.1	3	16.7	251	615	227	14.5	15	18	645	15	G30153
9506EX	60 – 70	2.1	3	15.5	251	615	227	14.5	15	18	645	15	G30154
9507EX	70 – 80	2.1	3	17.7	251	615	227	14.5	15	18	645	15	G30155
9508EX	80 – 90	2.1	3	16.2	251	615	227	14.5	15	18	645	15	G30156
9509EX	90 – 100	2.1	3	16.8	251	615	227	14.5	15	18	645	15	G30157
9520EX	12 – 20	2.7	5	12.8	251	615	227	14.5	15	18	645	15	G30158
9521EX	20 – 30	2.7	5	12.6	251	615	227	14.5	15	18	645	15	G30159
9522EX	30 – 40	2.7	5	15.8	251	615	227	14.5	15	18	645	15	G30160
9523EX	40 – 50	2.7	5	15.4	251	615	227	14.5	15	18	645	15	G30161
9524EX	50 – 60	2.7	5	16.6	251	615	227	14.5	15	18	645	15	G30162
9525EX	60 – 70	2.7	5	15.7	251	615	227	14.5	15	18	645	15	G30163



9354EX – 9359EX



9502EX – 9525EX

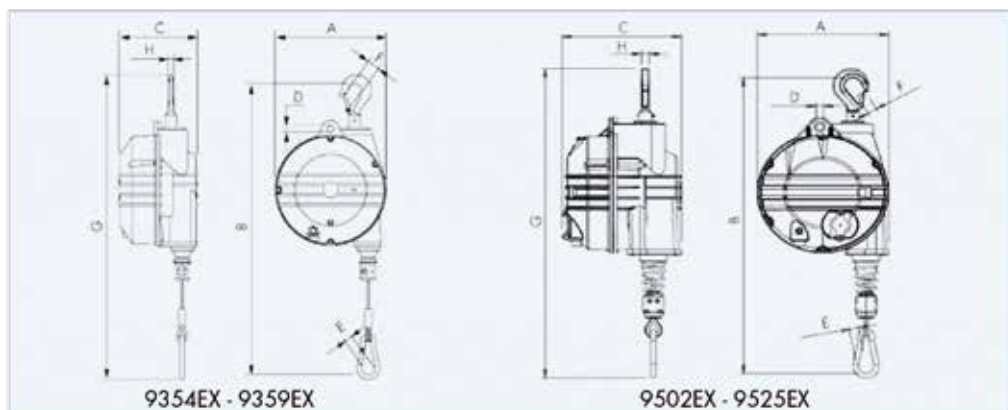

9354EX - 9359EX

9502EX - 9525EX