

Electric chain hoist MONTI

The new MONTI electric chain hoist is the ideal aid during assembly. Thanks to its light and compact construction, the chain hoist is easy to install and transport in the case supplied. It is ready for operation with a controller, chain and connection cable.

Features:

- 230 V / 1 ph / 50 Hz motor
- Soft start enables accurate placement
- 2 speeds: Main hoisting speed / precision hoisting speed infinitely adjustable
- Protection class IP54, insulation class F
- 24-Volt control voltage with EMERGENCY STOP
- FEM classification: M4 (1Am)
- Control cable length: 2.5 m
- Connection cable with two-pin earthed plug: 1.5 m
- Overload protection by slipping clutch
- Limit switch for top and bottom hook end position
- Includes chain box for 3 m standard lifting height and transport case



MONTI 480



Technical data

TYPE	MONTI ...	240	480
Rated load	kg	240	480
Motor output	W	600	
Duty rating	% ED	30	
Rated Current		230 V (5 A)	
Lifting speed	m/min.	0 – 3.4/12.8	0 – 1.6/6.3
Standard lifting height	m	3	
Number of chain falls		1	2
Load chain diameter	mm	4 x 12	
Net weight	kg	16.5	19.4
Packing (L x W x H)	mm	470 x 390 x 200	
MONTI ... with 3 m lift	Order No.	H20780	H20781
Additional for more lift/m	Order No.	H20782	H20783
Additional for 3 m Set of control cable elongation	Order No.	H20784	H20784
Additional for 6 m Set of control cable elongation	Order No.	H20785	H20785
Additional for 9 m Set of control cable elongation	Order No.	H20786	H20786



◀ MONTI is packed in a handy case for ease of transport.

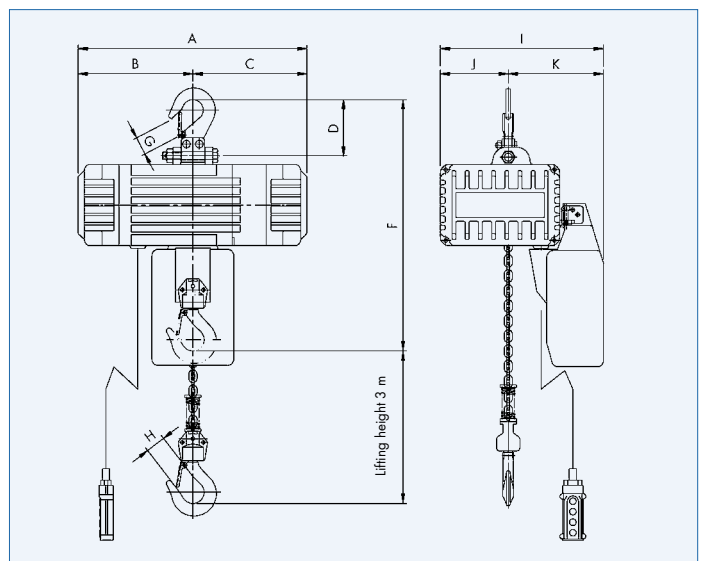

Chain box selection

TYPE MONTI ...	Rated load kg	Chain (mm)	Chain length (m)		
			up to 6	up to 12	up to 36
240	240	Ø 4 x 12	# 1	# 2	# 3
480	480		# 1	# 2	# 3

Chain box No.	Chain box dimensions (mm) L x W x H	Order No.
# 1	90 x 120 x 230	H20790
# 2	120 x 160 x 230	H20791
# 3	140 x 170 x 400	H20793

TYPE MONTI ...	Dimensions (mm)									
	A	B	C	D	F	G	H	I	J	K
240	364	182	182	89	400	25	25	260	108	152
480	364	182	182	109	497	31	30	260	84	176