

ERSATZTEILE | STROMLAUFPLÄNE PEHM 250

Spare parts | Pièces de rechange | Onderdelen | Reservedele | Varaosat |
Pezzi di ricambio | Reservedelen | Peças | Reservdelar | Piezas de recambio

Circuit diagrams | Schéma de connexions | Stroomschema | Kredsløbsdiagrammer |
KytKentäkaavio | Aansluitschema | Schema elettrico | Koplingskjema |
Esquema electrico | Elschema | Esquema eléctrico

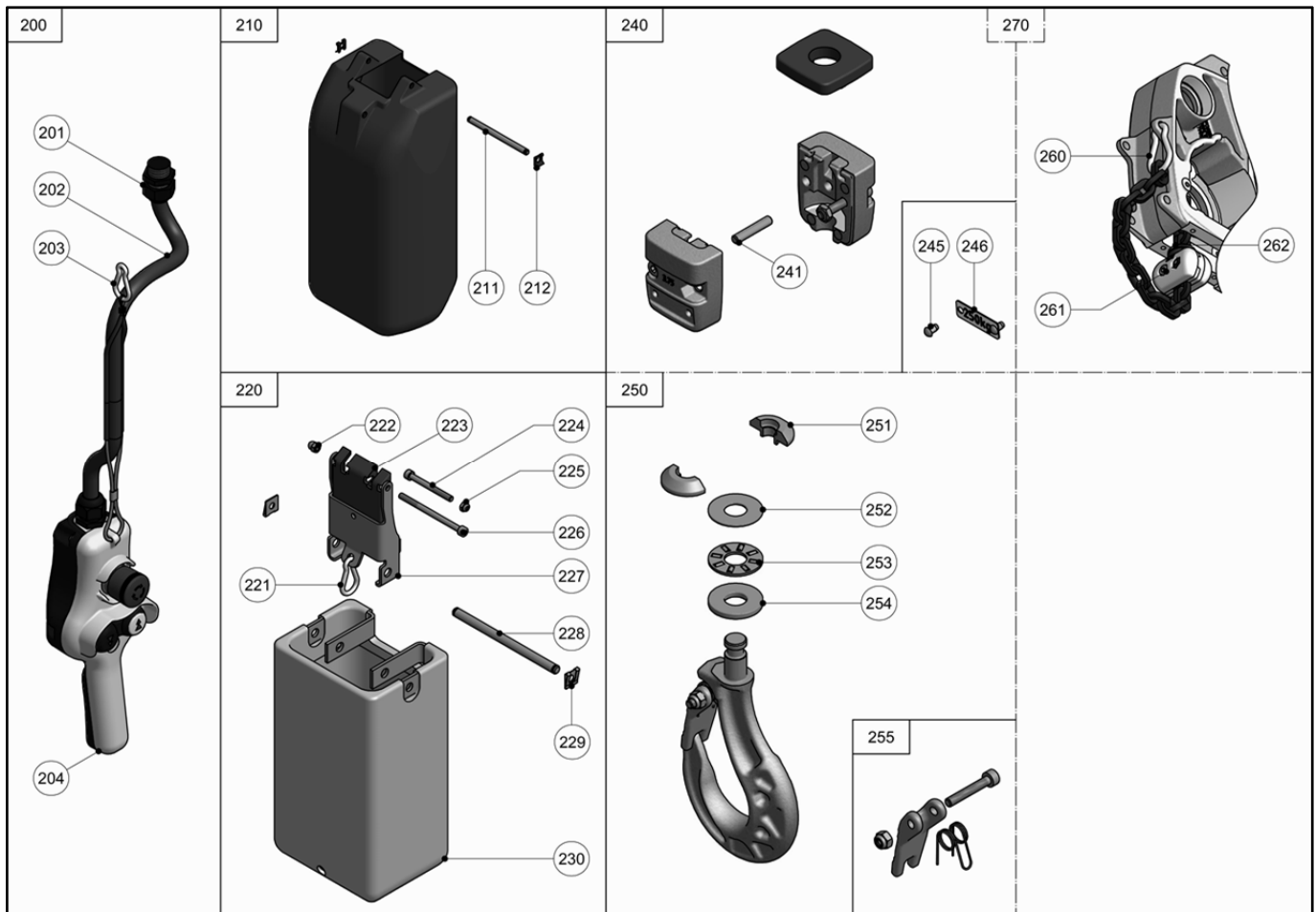

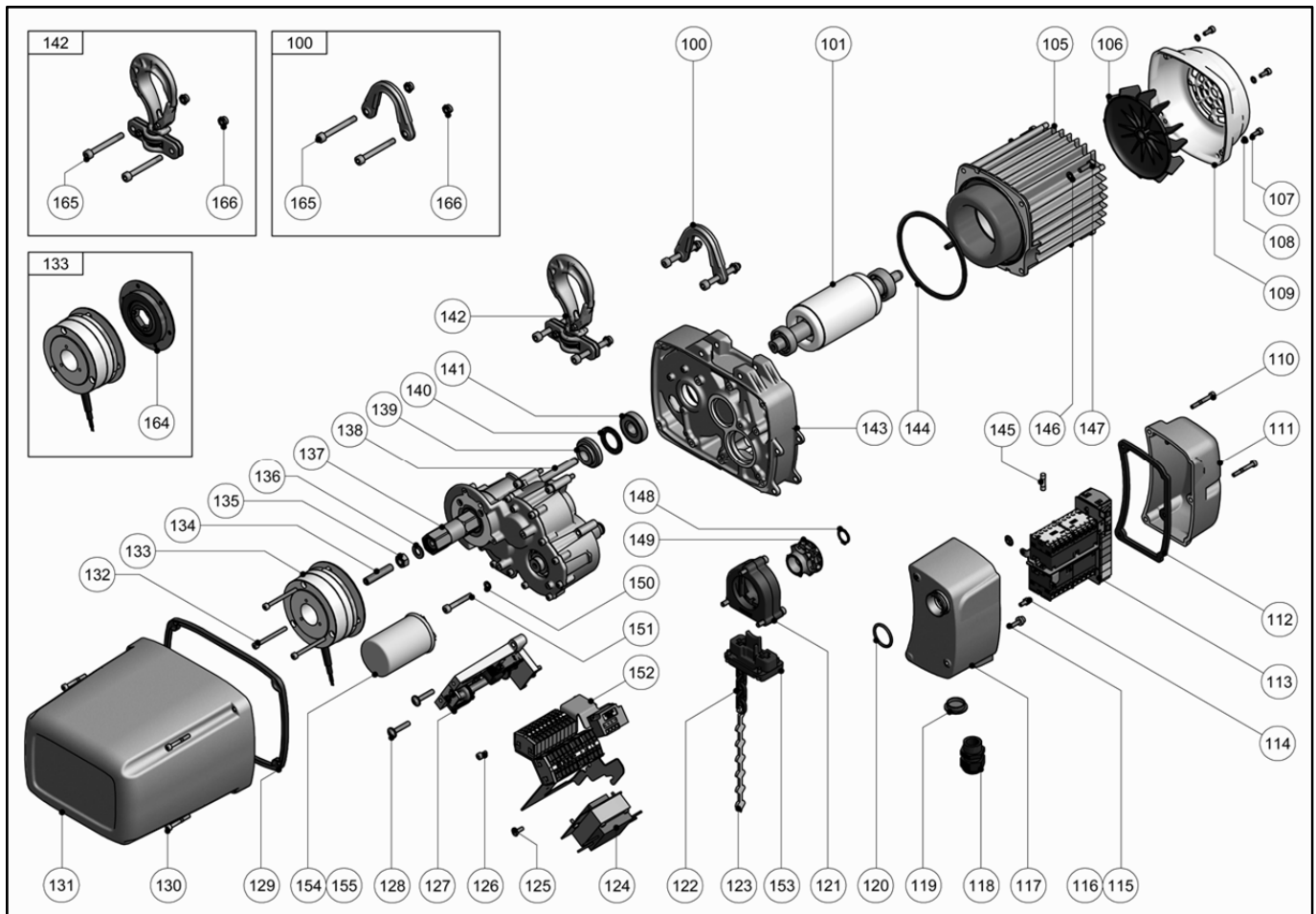

Elektrokettenzüge | Electric chain hoists | Palans électriques à chaîne

Schützensteuerung Contactor control Commande par contacteurs	1 Geschwindigkeit mit Not-Aus 1 speed with emergency stop 1 vitesse avec marche-arrêt	3 Ph	9500.9510.4
	2 Geschwindigkeiten mit Not-Aus 2 speeds with emergency stop 2 vitesses avec marche-arrêt	3 Ph	9500.9511.4
	1 Geschwindigkeit mit Not-Aus 1 speed with emergency stop 1 vitesse avec marche-arrêt	1 Ph	9500.9508.4

F	Steuersicherung	Control fuse	Fusible de commande
K	Schütz	Contacteur	Contacteur
L	Zuleitung	Power supply	Alimentation électrique
N	Nullleiter	Neutral	Neutre
NA	Not-Aus	Emergency stop	Marche-arrêt
PE	Erdung	Earth	Mise à la terre
S	Schalter	Switch	Interrupteur
T	Transformator	Transformer	Transformateur
U, V, W	Motor	Motor	Moteur
X	Klemmenleiste	Terminal strip	Bornier de raccordement
Y	Bremse	Brake	Frein

9500.9510.4 / 3 Ph

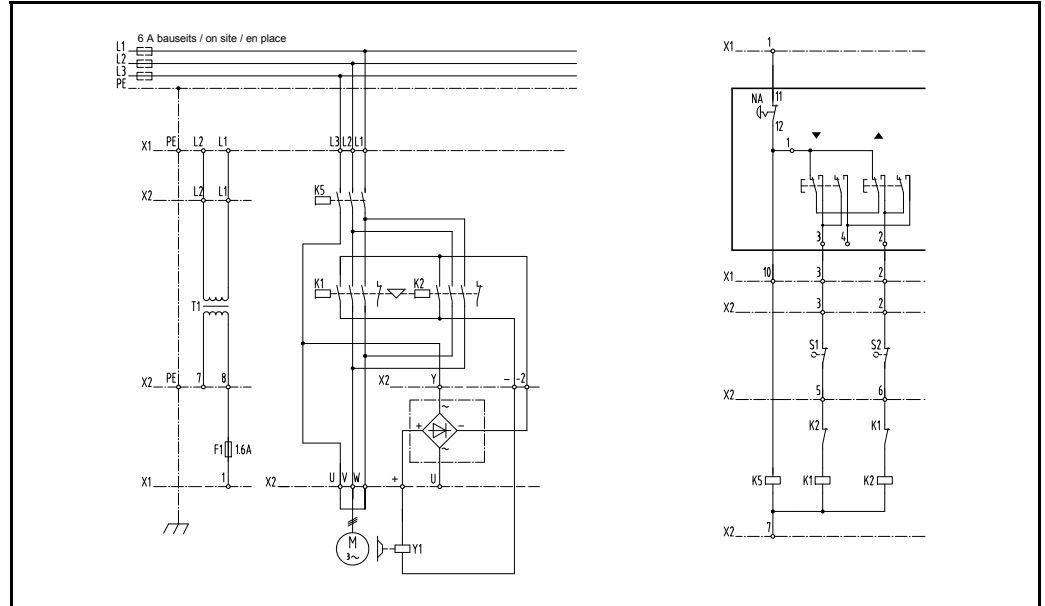

9500.9508.4 / 1 Ph

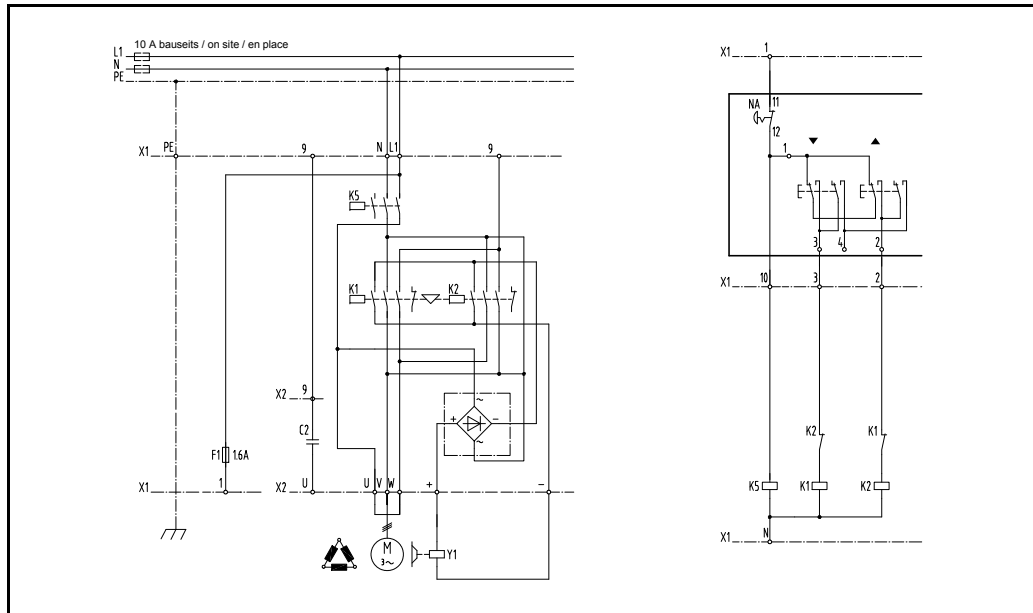

9500.9511.4 / 3 Ph

