

TRANSLATION OF THE ORIGINAL INSTRUCTION MANUAL PHF | PMF TROLLEY

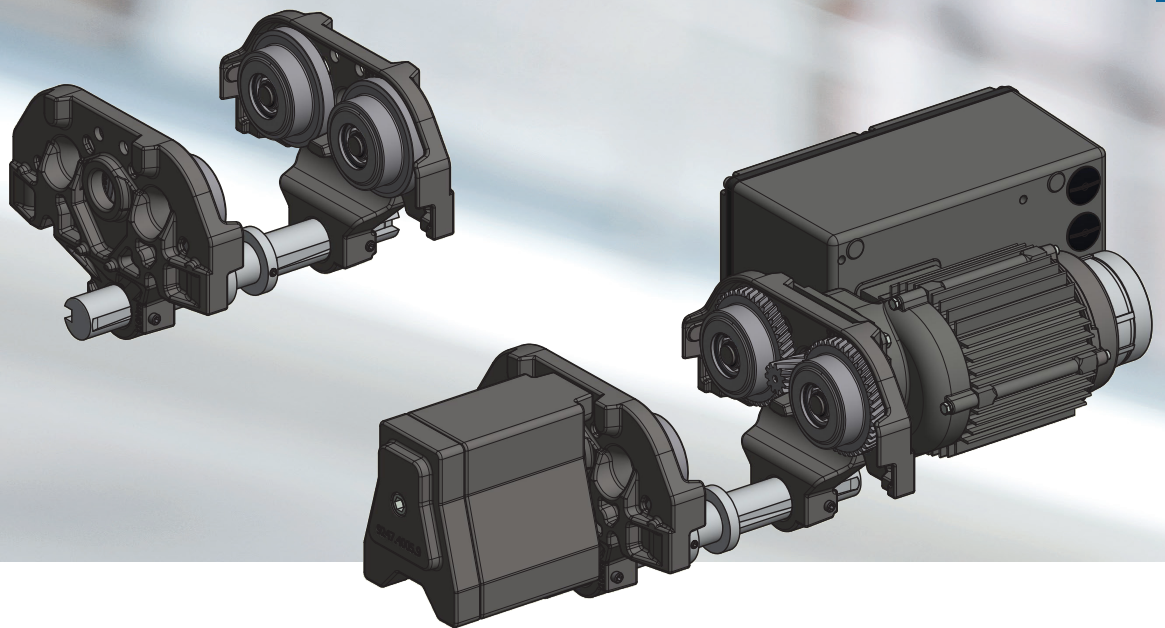

Table of contents

Spare parts / Ordering spare parts	4
0 General information	5
0.1 General safety instructions	5
0.1.1 Safety and hazard information	5
0.2 General safety regulations and organisational measures	5
0.2.1 Warning markings/Legends/Warning plates	5
0.3 Particular safety instructions	5
0.4 Instructions for hazard protection	6
0.4.1 Hazards - Mechanical	6
0.4.2 Hazards - Electrical	7
0.4.3 Sound pressure level	7
0.5 Technical status	7
0.5.1 Periodic checks	8
0.5.2 Warranty	8
0.6 Appropriate use	8
0.6.1 Use of the instruction manual	9
1 Description	9
1.1 Operating conditions	9
1.2 General description	11
1.3 Emergency stop	12
2 Start-up	12
2.1 Transport and assembly	12
2.2 Push trolley	13
2.3 Motorised trolley	14
2.3.1 Electrical connection	15
3 Care and maintenance	16
3.1 General guidelines for maintenance and repair	16
3.2 Care and maintenance	17
3.2.1 Care overview	17
3.2.2 Maintenance overview	17
3.2.3 Brake system	18
3.2.4 Transmission	18
3.2.5 Tightening torques	18
3.2.6 Load wheels	19
4 Measures for achieving safe operating periods	20
4.1 Determining the actual use	20
4.2 General overhaul	21
4.3 Disposal	21
5 Annex	22
5.1 Technical data	22
5.2 Electrical parameters	24
5.3 EC Declaration of Conformity	26
5.4 EC Declaration of incorporation	27

Spare parts / Ordering spare parts

The correct order numbers for original spare parts can be obtained from the relevant spare parts list. Please ensure that you have the following data on your trolley to hand. This will enable the correct spare parts to be supplied without delay.

Trolley type:

Serial number:

Year of manufacture:

Load capacity:

Original spare parts for the trolleys can be acquired from the following addresses:

Manufacturer

PLANETA-Hebetechnik GmbH Tel. +49 (0)23 25 - 95 80 - 0
Resser Straße 17 info@planeta-hebetechnik.de
44653 Herne www.planeta-hebetechnik.de

Resellers/Agent

0 General information

0.1 General safety instructions

0.1.1 Safety and hazard information

The following symbols and terms are used in this instruction manual for safety and hazard instructions:



WARNING !

Non-compliance, either in part or full, with operating instructions with this symbol can result in serious personal injury or fatal accidents. Warning information must be **strictly** adhered to.



ATTENTION !

Non-compliance, either in part or full, with operating instructions with this symbol can result in major damage to machinery, property or material. Information in the "Caution" category is to be **exactly** adhered to.



NOTE

Following the instructions marked with this symbol will lead to more effective and straightforward operation. "Note" directions make work easier.

0.2 General safety regulations and organisational measures

The instruction manual must always be available within the operating area of the trolley. The information on the trolley's type and data plate must be checked against Tables 5-1 to 5-6, page 22 to 23 and the corresponding dimensioned drawing. The dimensioned drawing also shows the dimensions of the trolley. This ensures that this instruction manual can be clearly assigned to the trolley. The instruction manual must be strictly adhered to. Furthermore, supplementary to the instruction manual, the statutory regulations governing general accident prevention and environmental protection are to be enforced.

Operating and service personnel must have read and understood the instruction manual, in particular the safety instructions, before commencing work. Protective equipment must be made available for operating and service personnel and worn at all times. The operator or their representative is responsible for supervising operating personnel and ensuring they are aware of the hazards and safety implications of working with the trolley.

The manufacturer reserves the right to make technical changes to the product or changes to these instructions and assumes no liability for the completeness and up-to-dateness of these instructions. The original version of these instructions is in the German language. In case of doubt, the original German original version is exclusively valid as a reference document.

0.2.1 Warning markings/Legends/Warning plates

- CE signFigure 0-1
- Type plateFigure 0-2
- Data plate Figure 0-3
- Voltage..... Figure 0-4

Figure 0-1



Figure 0-2

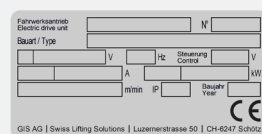

Figure 0-3

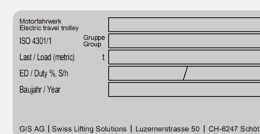

Figure 0-4



0.3 Particular safety instructions

Transport/Assembly:

- Trolleys, single parts and large components should be carefully fixed to suitable and technically acceptable hoists/load handling devices.

Connection:

- Connection work is only to be performed by personnel specifically designated and trained for the job.

Start-up/operation:

- Before initial start-up, as well as daily start-up, carry out a visual check and the stipulated user-checks routine.
- Only operate the trolley if the protective and safety equipment provided is ready and working.
- Damage to the trolley and changes in its operational characteristics must be reported immediately to the responsible person.
- After use, or when in a non-operational mode, the trolley should be secured against unauthorised and unintentional use.
- Refrain from hazardous procedures.

See also operational parameters (Chapter 0.6).

Cleaning/service/repair/maintenance/refitting:

- Use working platforms provided for installation work at high level.
- Do not use machine parts for this purpose.
- Check electrical cables for damage or wear.
- Ensure any oils or other agents used are collected and disposed of safely and in an environmentally sound manner.
- Reassemble and check safety devices that have been disassembled for maintenance or repair of the hoist once service and repair work has been completed.
- Adhere to predefined testing and service intervals specified in the instruction manual.
- Follow the directions in the instruction manual regarding exchanging parts.
- Operating personnel should be informed before commencing special or repair work.
- Secure the repair working area.
- Prevent the trolley from being unexpectedly switched on during maintenance or repair work.
- Attach warning plates.
- Disconnect the power cable and ensure it cannot be switched on again by unauthorised personnel.
- Retighten screw connections that have been loosened for repair or maintenance work.
- Replace non-reusable fixing elements and sealings (e.g. self-locking nuts, washers, cotter pins, O-rings and seals).

Shut down/storage:

- Clean and preserve (lubricate/grease) the trolley before long periods of inactivity or storage.

0.4 Instructions for hazard protection

Hazardous areas must be clearly marked by warning plates and cordoned off. It must be ensured that warnings regarding hazardous areas are given due attention.

Hazards can stem from:

- incorrect application
- not following safety directions properly
- not carrying out test and service work thoroughly

0.4.1 Hazards - Mechanical

**Physical injury:****Unconsciousness and injury through:**

- crushing, shearing, cutting and twisting
- drawing in, ramming, piercing and rubbing
- slipping, stumbling and falling

Causes:

- crushing, shearing and twisting
- parts rupturing or bursting

Safety options:

- keep floor, equipment and machinery clean
- eliminate leakages
- observe the required safety distance

0.4.2 Hazards - Electrical

Work on electrical apparatus or machinery may only be performed by qualified electricians or persons under the supervision and guidance of qualified electricians, in accordance with electrical regulations.



Physical injury:

Death from electrical shock, injury and burns through:

- contact
- faulty insulation
- faulty maintenance or repair work
- short circuit

Causes:

- contact with, touching or standing too close to uninsulated power and live parts.
- use of uninsulated tools.
- exposed electricity supply terminals following insulation failure.
- inadequate safety checks following repair work.
- incorrect fusing.

Safety options:

- Isolate machinery and equipment designated for repair or maintenance work before commencing such work.
- First check isolated parts for voltage.
- Regularly check electrical fittings.
- Replace loose or damaged cables immediately.
- Always replace blown fuses with fuses of the correct type/value.
- Avoid contact with or touching live terminals.
- Only use insulated tools.

0.4.3 Sound pressure level

Tests on the motorised trolley sound level are performed at a range of 1, 2, 4, 8 and 16 m from the centre of the trolley motor to the measuring device. Measurement of SPL per DIN 45635.

The SPL was measured:

- a) During operation of motorised trolleys on factory site.
- b) During open-air operation of motorised trolleys.

Table 0-1 Sound level

Measuring distance		1 m	2 m	4 m	8 m	16 m
Series	Measurement type	dBA				
PMF 1250/2500, PMF 1250/2500 1Ph	a	75	72	69	66	63
	b	75	69	63	57	51
PMF 5000/6300	a	75	72	69	66	63
	b	75	69	63	57	51



When working in a noisy environment, the use of ear protection is recommended.

0.5 Technical status

This instruction manual was issued in 2020. It corresponds to directive 2006/42/EC of the European Parliament and council of 17 May 2006 (including its amendments).

0.5.1 Periodic checks

Each device/unit operator should adequately note all checks, maintenance and inspections performed in the inspection pass, and have these confirmed by the competent person in charge. Incorrect or missing entries will lead to forfeiture of the manufacturer's warranty.



Devices and cranes are to be checked periodically by a specialist. Primarily, visual and functional checks are to be carried out, whereby the state of components with respect to damage, wear, corrosion or any other changes is determined. In addition, safety equipment is assessed for completeness and efficiency. It may be necessary to dismantle the equipment to correctly assess wear parts.



Load-bearing parts must be inspected over their entire length, including covered or hidden parts.



All periodical inspections should be arranged by the operator.

0.5.2 Warranty

The warranty is void if the installation, operation, testing and maintenance is not carried in accordance with this instruction manual. Repairs and troubleshooting under warranty may only be carried out by qualified persons after consultation and agreement with the manufacturer/supplier. Any modifications to the product or the use of non-original spare parts will void the warranty.

0.6 Appropriate use

The trolleys of the PHF and PMF series are trolleys for various lifting capacities. The trolleys are manufactured in accordance with the la-test technical developments and recognised safety standards, and are tested for safe operation by the manufacturer. Trolleys are approved by various international classification societies (such as TÜV in Germany) and others. Trolleys of the above series may only be used when in an acceptable technical condition, in accordance with their intended use, by trained personnel in a safe and responsible manner.

General operating conditions:

- Ambient temperature : -15 °C to +50 °C
- Humidity..... : max. 80% relative humidity
- Protection class : IP 54
- Electromagnetic compatibility..... : Immunity, industrial area

We recommend equipping trolleys used outdoors with a canopy to protect them from the weather or to move the chain hoist, trolley and travel drive under a canopy when not in use. Special operating conditions can be agreed in individual cases with the manufacturer. After consultation, appropriate, optimised equipment, and important information for safe, low-wear use can be supplied. The intended use of the trolleys likewise assumes the adherence to the operating, maintenance and servicing prescribed by the manufacturer.

Improper use comprises:

- exceeding the defined maximum permissible load capacity
- pulling the load diagonally (maximum angle 4°, see Figure 0-5)
- heaving, pulling or dragging the load
- transporting persons
- moving loads over persons
- standing under suspended loads (see Figure 0-6)
- transporting excessive loads
- pulling on the control cable
- failing to observe the load constantly
- use in an explosive environment

Refer also to Chapter 0.3.

Figure 0-5

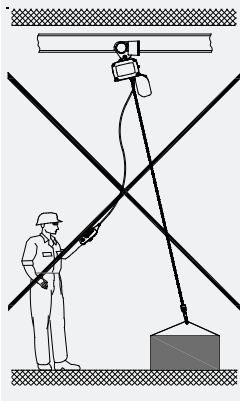
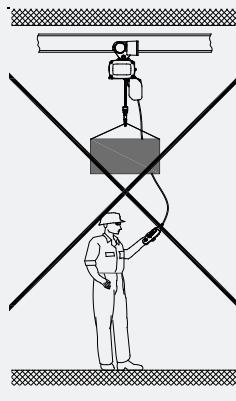

Figure 0-6



Excessive inching operations and driving against the limit stops should be avoided. The loads shall be lifted off the ground with the lowest available lifting speed (per EN 14492). If these instructions are not followed, the manufacturer accepts no liability for damage to equipment and third parties caused by such actions.



With pole-changeable motors the low speed is only suitable for driving and braking. In short time operation max. 20% of the fast gear duty cycle.

0.6.1 Use of the instruction manual

This instruction manual includes the following chapters:

- | | |
|-----------------------|---|
| 0 General information | 3 Care and maintenance |
| 1 Description | 4 Measures for achieving safe operating periods |
| 2 Start-up | 5 Appendix |

Supplementary to the instruction manual, the following documentation from the operator must be noted:

- Declaration of conformity
- Inspection pass
- Spare parts list(s)
- Circuit diagrams

Page and figure numbering:

The pages are consecutively numbered. Blank pages are not numbered, however are calculated together with the consecutive pages. Figures are numbered consecutively by chapter. Example: Figure 3-1 means: in Chapter 3, Figure 1.

1 Description

The series includes the following models: PHF, PMF.

1.1 Operating conditions

Classification according to application requirements:

Trolleys are categorised in accordance with the following regulations into classifications:

- DIN EN 14492-2 (A5 = 125,000 cycles)
- ISO 4301-1 (M5 = 1 600 h)
- Remarks about general overhaul (see Chapter 4)

There is different coefficient data for the classifications that must be adhered to in operation.



The trolley must have at least the same lifting capacity as the chain hoist.



The classification of the trolley can be found on the data plate.

The manufacturer will only guarantee the safety and lasting operation of the trolley when used for applications in accordance with valid standard values that fall within its classification.

Before the initial start-up, the user must estimate according to the parameters in Table 1-1, which of the four types of load is applicable to the use of the trolley during its whole life cycle. Table 1-2 shows standard values for the operating conditions of the classifications depending on the type of load and number of cycles.

Table 1-1 Load spectrums

Load type Q2 light $Q < 0.50$ $Q = 0.50$	Load type Q3 medium $0.50 < Q < 0.63$ $Q = 0.63$	Load type Q4 heavy $0.63 < Q < 0.80$ $Q = 0.80$	Load type Q5 very heavy $0.80 < Q < 1.00$ $Q = 1.00$
Full load only by way of an exception, however predominantly low loads	Often fully loaded, however continuously lightly loaded	Frequently fully loaded, continuous average loading	Regular full loading

Q = Load spectrum (type of load)

Table 1-2 Operating conditions

Classification per DIN EN 14492-2 (ISO 4301-1)	A3 (M3)	A4 (M4)	A5 (M5)	A6 (M6)
Load spectrum	Number of cycles per working day (travel classes Dt2 - Dt5, travelling speed 12 m/min)			
Q2 - light $Q < 0.50$	120	240	480	960
Q3 - medium $0.50 < Q < 0.63$	60	120	240	480
Q4 - heavy $0.63 < Q < 0.80$	30	60	120	240
Q5 - very heavy $0.80 < Q < 1.00$	15	30	60	120

Ascertaining the correct type of application for a trolley:

Either the number of cycles or expected type of load can be used as a basis for ascertaining the correct type of application for the trolleys.



Before initial start-up of the trolley, it is necessary to ascertain which of the load types in Table 1-1 applies to the operation of the trolley. Assignment to a load type or a load spectrum (Q) applies for the whole service life of the equipment and may not be altered for operational safety reasons.

Example 1: Calculate permissible operating time of the trolley

A trolley of the classification A4 is to be used for medium stress load tasks throughout its whole calculated service life. This corresponds to the type of load "Q4 heavy" (see Table 1-1). Corresponding to the values in Table 1-2, the trolley should not be used for more than 60 cycles per day.

Example 2: Calculate the permissible type of load

A trolley of the classification A5 is to be used for approximately 400 cycles per working day, throughout its whole service life. Thus, the trolley must be operated in accordance with the characteristics of the type of load "Q2 light" (see Table 1-1).

1.2 General description

Figure 1-1 PHF/PMF 1250/2500

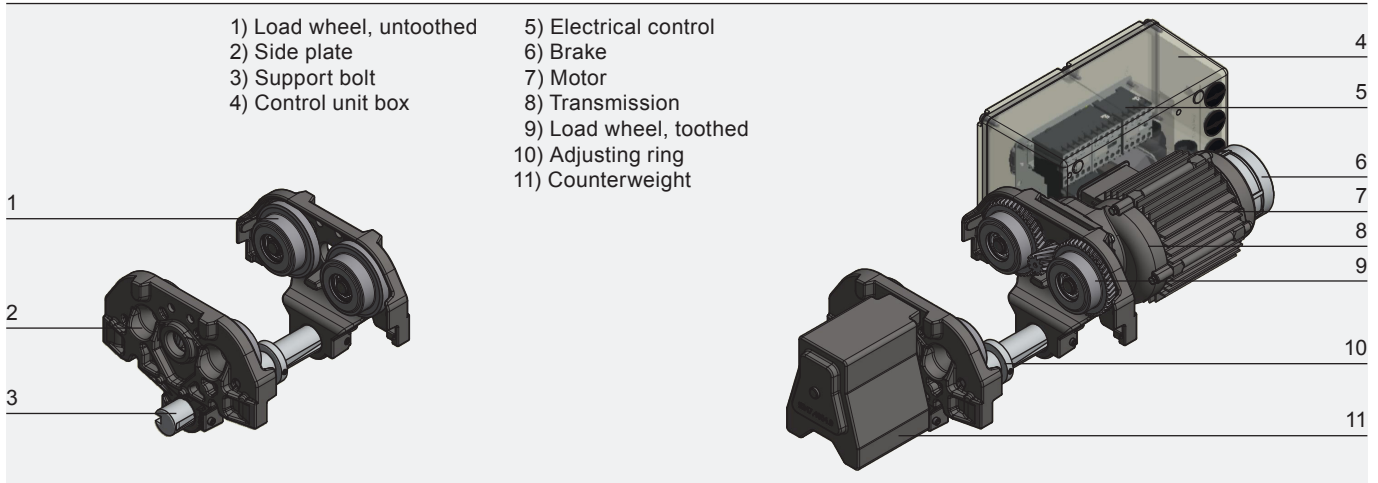
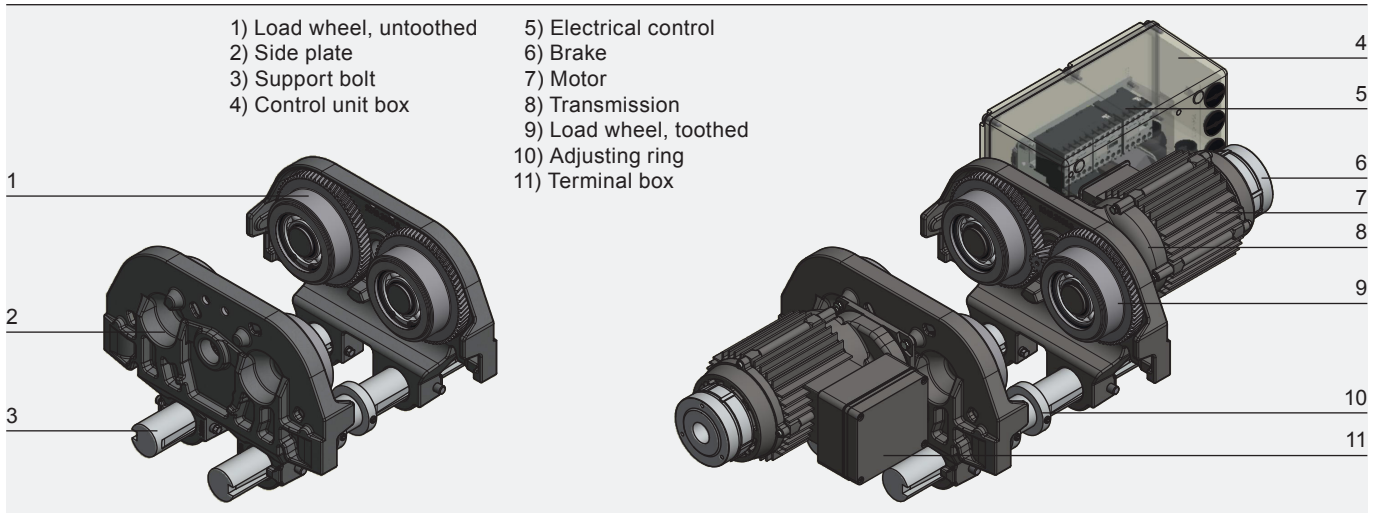

Figure 1-2 PHF/PMF 5000/6300



The trolley meets the requirements of the EC Machinery Directive and the harmonised EN standards. The side plate is made of robust grey cast iron and is equipped with a fall arrester. Depending on the series, one (Figure 1-1) or two support bolts (Figure 1-2) are required for assembly. The support bolt is made of special steel. The flange width can be adjusted to suit individual requirements (see Table 5-7). Two adjusting rings in the middle fix the chain hoist. The original version of the load wheels is suitable for flat flanged brackets (Figure 1-3), made of grey cast iron and fitted with ball bearings. On the push trolley (PHF), the four load wheels are not toothed, while on the motorised trolley (PMF) the driven load wheels are toothed.

The drive (GAT) of the motorised trolleys consists of an asynchronous motor and a transmission. The PMF 1250 and PMF 2500 motorised trolleys are equipped with a drive (Figure 1-1) and the PMF 5000 and PMF 6300 motorised trolleys have a drive on both sides (Figure 1-2). Two-speed models include a pole-changeable version of the motor. The motors comply with the legal requirements for trolleys. The winding corresponds to insulation class F. The drives are generally equipped with a brake. The spur gear (N/S) reduces the speed of the motor to the load wheel.

The motorised trolleys are equipped with a 42 V contactor control as standard. The generally built-in emergency stop contactor disconnects all three main phases from the mains when the red button is pressed. The standard equipment of the motorised trolley includes a control switch (up/down and forward/back with emergency stop). The forced disconnecting emergency stop contact of the control switch immediately opens the circuit for supplying the contactors.

The counterweight is required for a motorised trolley to balance the mass of the drive motor and the control. To prevent tipping, an additional weight is added for small flange widths.

Options:

- Load wheels for conical brackets (spherical load wheels, Figure 1-4)
- Support rollers for use on single-rail tracks with bends (Figure 1-5)
- Trolleys in corrosion-resistant design (PHFR/PMFR) with plastic or steel load wheels
- Motorised trolleys with protection class IP 65
- Motorised trolleys with food grade grease
- Motorised trolleys in dustproof or gasproof design (ATEX)
- Motorised trolleys with frequency control (FU)
- Motorised trolleys with radio remote control (Figure 1-6)
- Motorised trolleys with limit switch (Figure 1-7)
- Push trolley PHF 1250 with parking brake

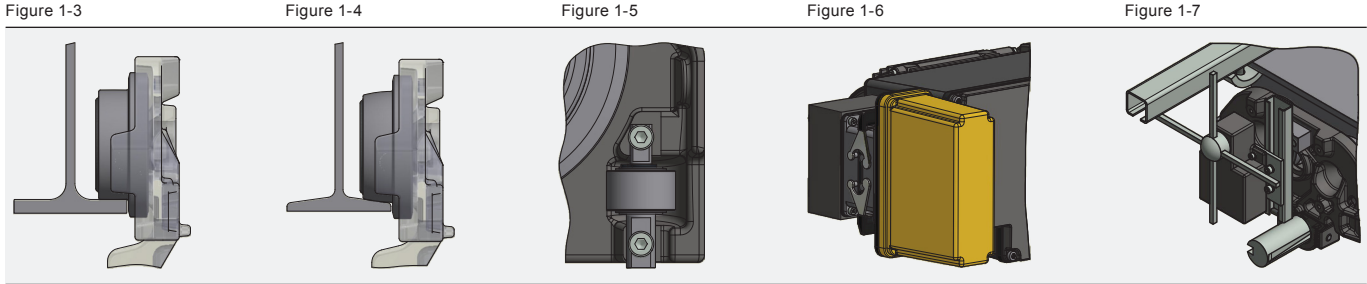

1.3 Emergency stop

By pressing the emergency stop button, the power supply to the trolley is interrupted in all phases. The movement of the trolley is stopped immediately. To unlock the emergency stop button, it must be turned in the indicated direction.



After an emergency stop, the operator may only restart the trolley after a competent person is satisfied that the cause which led to the emergency stop has been eliminated and that there is no longer any danger from further operation of the system.

2 Start-up



Mechanical adjustments may be performed by authorised specialists. If no tightening torques are specified for screw connections, the general information in Chapter 3.2.5 applies.



Operating staff must carefully read the instruction manual of the trolley before initial start-up and carry out all the checks. The device shall be put back into operation only after operational safety has been established. Unauthorised persons may neither operate the device nor carry out work with it.



The operator must create an inspection pass during the start-up of the trolley. The inspection pass contains all the technical data and the date of start-up. It provides a record of all servicing and maintenance work.

2.1 Transport and assembly

The safety directions for handling with loads should be followed (see Chapter 0.3) when transporting and assembling the trolley. Trolleys must be assembled by qualified staff, always bearing in mind the accident prevention directions (see Chapter 0.2). Before assembly, the trolley must be stored in an closed room or covered area. Should the trolley be destined for operation outdoors, then it is recommended that a protective cover is erected to shield it from the effects of the weather.

Wherever possible, the trolley should be transported in its original packaging. The goods delivered should be checked for completeness and the packaging disposed in an environmentally sound manner. It is recommended that the trolley is assembled and connected on-site by skilled personnel.

2.2 Push trolley

Checking the lifting capacity:

The lifting capacity of the trolley must be at least equal to the lifting capacity of the electric chain hoist.

Checking the flange width:

The flange width of the bracket must be within the adjustment range of the support bolt supplied (see Table 5-7).

Installation of the trolley (see Figure 2-1):

The two side plates (1) are pushed onto the support bolt with the adjusting rings (2) and fixed with the grub screws (3). These must be tightened to a torque of 10 Nm. When doing so, it must be ensured that the excess length of the support bolt is evenly distributed on both sides. For the installation of a chain hoist it may be necessary to remove an adjustment ring.



The running clearance between the load wheel and the bracket must be 1.5 mm each (see Figure 2-2).



The grub screws for fixing the support bolt to the side plate are provided with a captive screw lock. The grooves in the support bolt must be aligned exactly with the grub screws. The grub screws cannot be reused (see Figure 2-3).



The grub screws for fixing the adjusting rings on the support bolt are provided with a captive screw lock. The grub screws must be aligned exactly with the holes in the support bolt (PHF 1250/2500 see Figure 2-4 and PHF 5000/6300 see Figure 2-5).

Figure 2-1

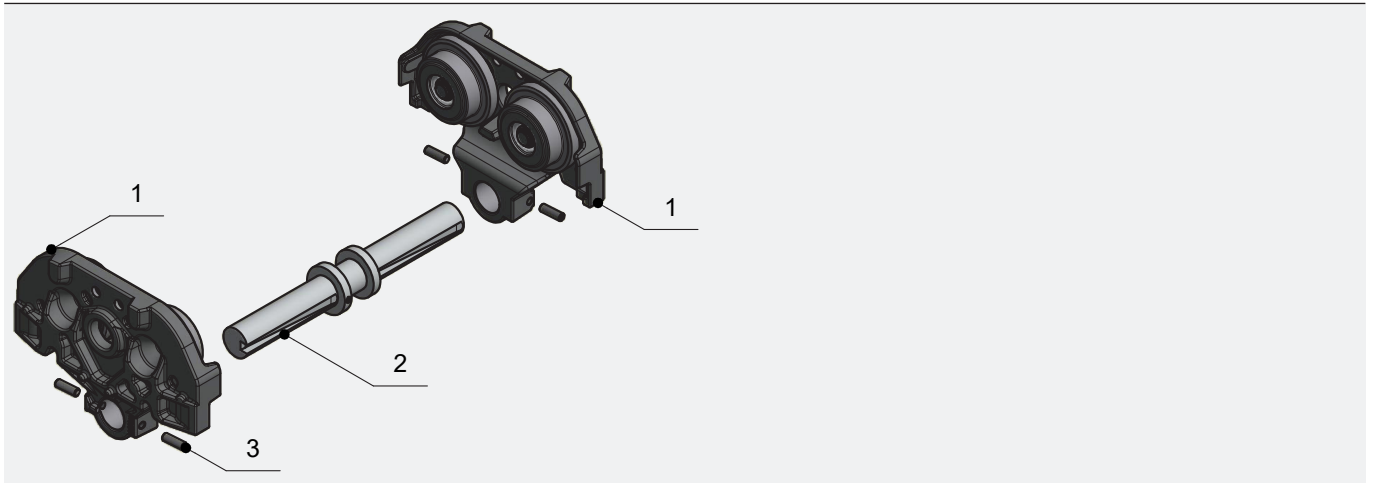

Figure 2-2

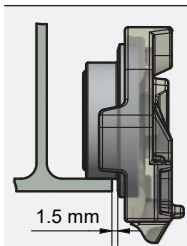

Figure 2-3

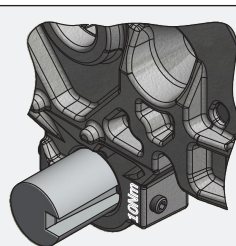

Figure 2-4

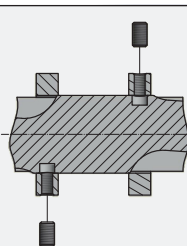
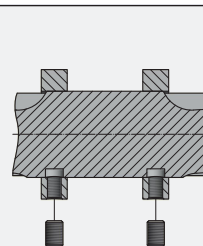

Figure 2-5



2.3 Motorised trolley

Checking the lifting capacity:

The lifting capacity of the trolley must be at least equal to the lifting capacity of the electric chain hoist.

Checking the flange width:

The flange width of the bracket must be within the adjustment range of the support bolt supplied (see Table 5-7).

Installation of the trolley (see Figure 2-6):

The counterweight (1) is attached to the side plate with untoothed load wheels (2) using two screws (3). The drive (4), consisting of transmission, motor and control, is installed on the side plate with toothed load wheels (5) using four screws. The two side plates are now pushed onto the support bolt with the adjusting rings (6) and fixed with the grub screws (7). These must be tightened to a torque of 10 Nm. When doing so, it must be ensured that the excess length of the support bolt is evenly distributed on both sides. For the installation of a chain hoist it may be necessary to remove an adjustment ring.



The running clearance between the load wheel and the bracket must be 1.5 mm each (see Figure 2-7). To prevent the trolley from tipping over, an additional weight must be bolted to the counterweight if the flange width is small (see Figure 2-8).



The grub screws for fixing the support bolt to the side plate are provided with a captive screw lock. The grooves in the support bolt must be aligned exactly with the grub screws. The grub screws cannot be reused (see Figure 2-9).



The grub screws for fixing the adjusting rings on the support bolt are provided with a captive screw lock. The grub screws must be aligned exactly with the holes in the support bolt (PHF/PMF 1250/2500 see Figure 2-10 and PHF/PMF 5000/6300 see Figure 2-11).

Figure 2-6

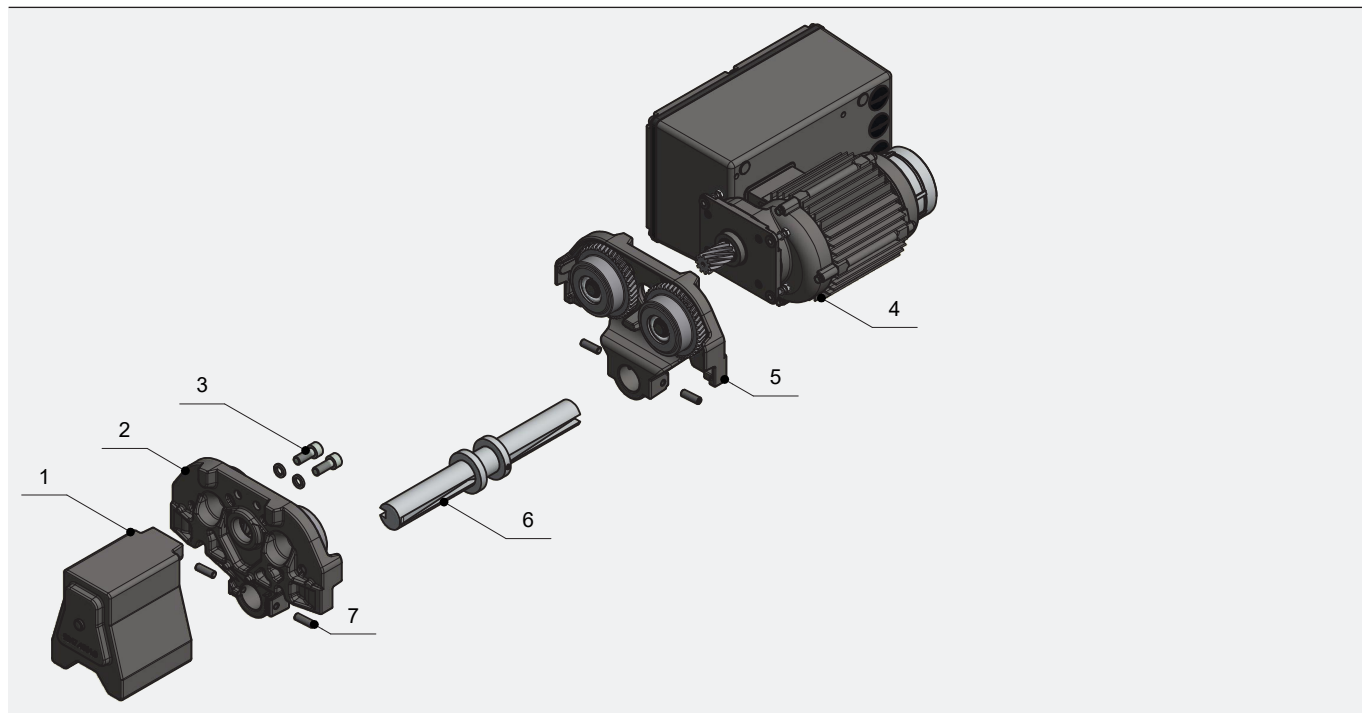

Figure 2-7

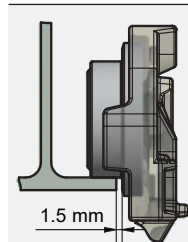

Figure 2-8

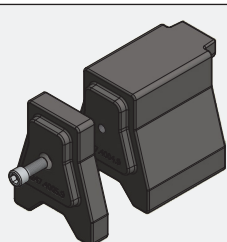

Figure 2-9

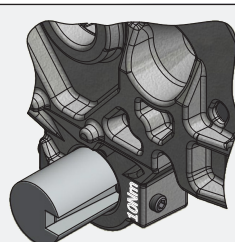

Figure 2-10

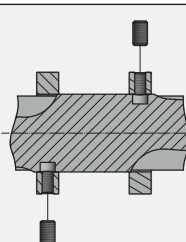
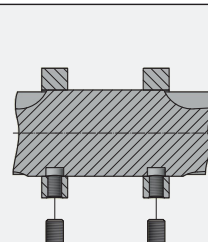

Figure 2-11



2.3.1 Electrical connection



Electrical installations may only be performed by authorised specialists.

The mains connection cable, the mains connection fuse and the main switch for connecting the motorised trolley to the mains power supply must be provided by the customer. A 4-wire cable with a PE protective conductor is needed as a supply line for three-phase versions. A 3-wire cable with a protective conductor is adequate for single-phase version. The length and cross-section must be appropriate for the power consumption of the motorised trolley and the electric chain hoist. An electrical circuit diagram is enclosed with each motorised trolley.

- Before connecting the motorised trolley, check whether the operation voltage and frequency specified on the type plate correspond to the available power supply.
- Remove the cover from the control unit box.
- Introduce the mains connection cable with cable gland M25 × 1.5 through the rear lower hole and connect in accordance with the attached electrical circuit diagram to L1E L2E, L3E and PE (see Figure 2-12).
- When operating an electric chain hoist, introduce the connection cable with cable gland M25 × 1.5 into the side hole and connect it to terminals 1H, 2H, 3H, 4H, L1A, L2A, L3A and PE (see Figure 2-13). On the electric chain hoist, the connection cable is connected to terminals 1, 2, 3, 4, L1, L2, L3 and PE. Terminals 1 and 10 must be bridged.
- For the PMF 5000 and PMF 6300 types, a connection cable is supplied for both drive motors. It is connected on both sides to the motor connections U, V1, W1, V2, W2 and for the brake to U and L2.
- Introduce the control cable from the 4-button control switch with cable gland M25 × 1.5 into the front lower hole and connect to terminals 1, 2, 3, 4, 50 for the travel movement and 1H, 2H, 3H, 4H for the lifting movement. Install the cable internal strain relief on the control plate (see Figure 2-14).
- Re-fit the cover from the control unit box.



- To maintain the predetermined protection class IP 54, all cables must fit into the corresponding cable glands and the cover screws must be tightened after the connection with the torque specified in Table 3.2.5.
- Open holes must be provided with a sealing plug.
- The control switch must be attached to the strain relief cord and not to the cable.

Figure 2-12

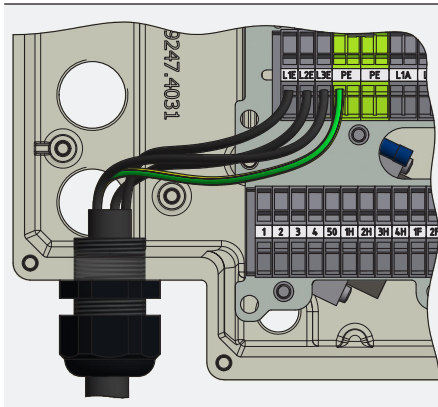

Figure 2-13

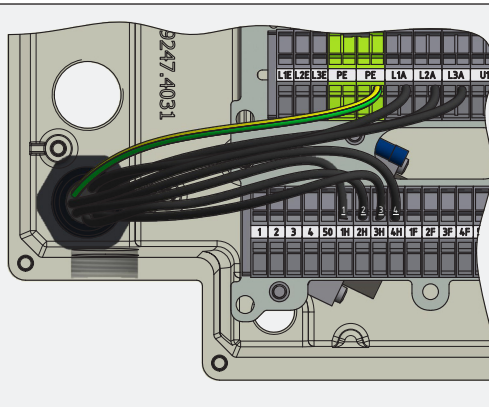
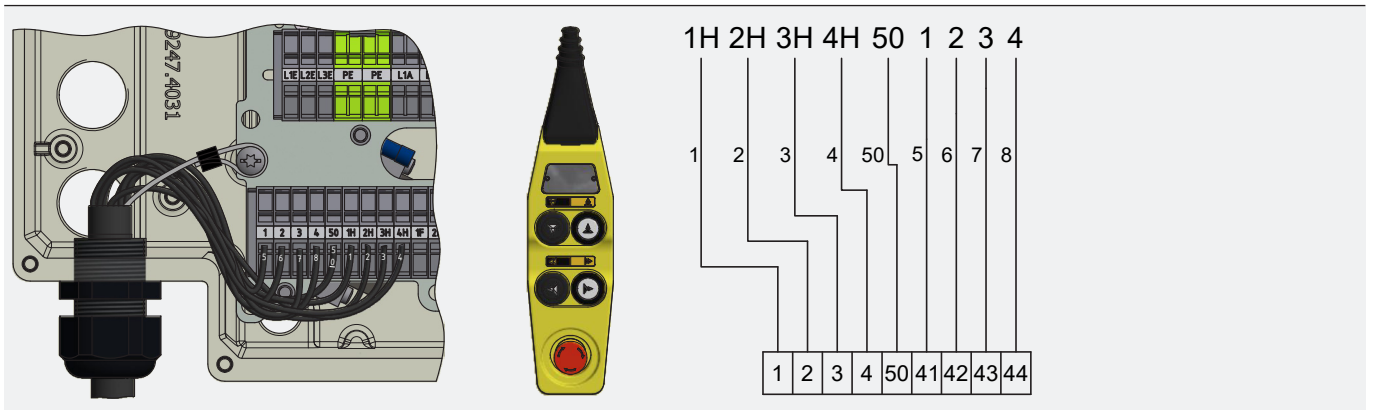

Figure 2-14





The protective conductor should not conduct any current during operation. With the installation of a motor protection breaker, the current of the motorised trolley and electric chain hoist must be observed in accordance with the type plate.



Checking direction of rotation: If the directions of movement do not match the button symbols of the control switch, the supply line wires L1 and L2 must be transposed.



Open the terminal used in accordance with Figure 2-15.

Figure 2-15

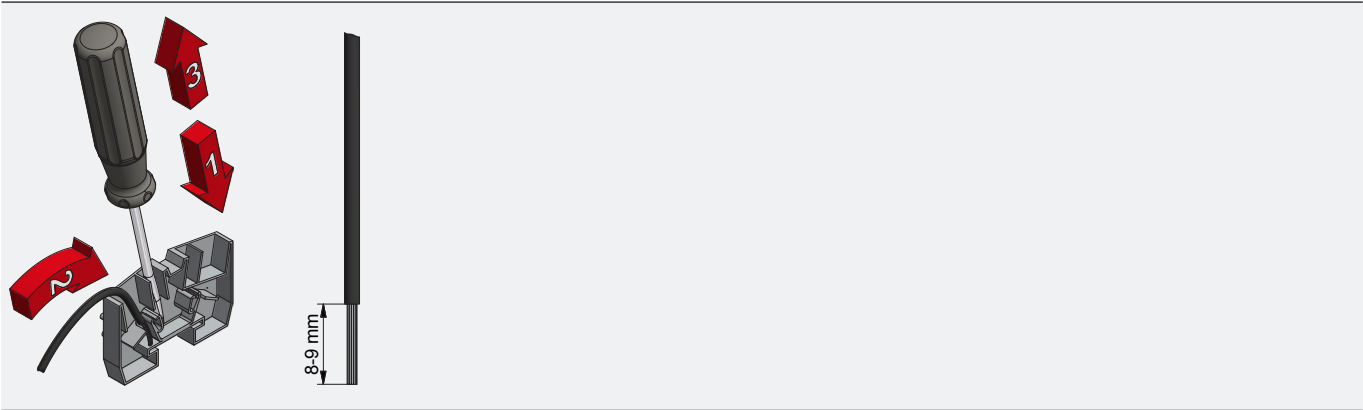

3 Care and maintenance

3.1 General guidelines for maintenance and repair

General guidelines for maintenance and repair



Maintenance and repair work on the trolley may only be carried out by qualified and trained personnel.



If the operator performs maintenance work on a trolley on their own, the type of maintenance performed together with the date carried out must be entered in the inspection pass.

Alterations, as well as modifications and additions to trolleys, which may affect safety, must be authorised by the manufacturer in advance. Structural alterations to trolleys not authorised by the manufacturer exempt the manufacturer from liability in the event of damage. Material warranty claims will only be recognised as valid if original manufacturer's spare parts are used exclusively. We explicitly advise that original parts and accessories not delivered by us are also not checked or approved by us.

General:

Care and maintenance tasks are preventive measures designed to preserve the full functionality of trolleys. Non-compliance with care and maintenance routines can result in limited use and damage to trolleys.

Care and maintenance should be carried out in accordance with the instruction manual at predefined time intervals (Table 3-1 and 3-2). During care and maintenance work, general accident prevention directions, special safety directions (Chapter 0.3) as well as hazard protection instructions (Chapter 0.4) should be followed.



Care and maintenance work should be performed only on trolleys with no loads. The main switch must be off.

Care work encompasses visual checks and cleaning routines. Maintenance work includes additional functional checks. During the functional checks, all fixing elements and cable clamps must be checked for tightness. Cables must be inspected for dirt, discolouration and arc spots.



Used operating materials (oil, grease, etc.) should be safely collected and disposed of in an environmentally friendly manner.

Care and maintenance intervals are defined as follows:

d (daily), 3 M (quarterly), 12 M (annually)

The predefined care and maintenance intervals should be reduced when the loading of the trolleys is exceptionally large or when frequently operated in adverse conditions (e.g. dust, heat, humidity, steam, etc.).

3.2 Care and maintenance

The trolleys are largely maintenance-free. Unusual noises during daily use must be reported to the competent authority immediately. A pending repair must be carried out immediately.

3.2.1 Care overview

Table 3-1 Care overview

Designation	t	3 M	12 M	Task	Remark
1. Trolley	x			check for abnormal noise / sealing	
2. Electric power supply cable	x			Visual check	
3. Sealing		x		Visual check	
4. Strain relief control cable	x			Visual check	

3.2.2 Maintenance overview

Table 3-2 Maintenance overview

Designation	t	3 M	12 M	Task	Remark
1. Brake system	x		x	function check with load	Chapter 3.2.3
2. Electrical equipment			x	function check	
3. Support bolt			x x	check for cracks check screw torque	Chapter 3.2.5
4. Load wheels			x	Check for wear	Chapter 3.2.6
5. Drive, toothing			x	Visual inspection for wear	Chapter 3.2.4
6. Leaktightness			x	check screw torques of the covers	Chapter 3.2.5

3.2.3 Brake system

The spring-loaded brake is a solenoid-operated, single disc brake with two friction surfaces. The braking force is applied by a spring. The braking torque is generated when no current is applied. The brake release is solenoid-operated. The brake operates with AC current.



The brake coil voltage must be the same as the operation voltage.



The brake has no air gap adjustment. If the maximum air gap is reached (a max., Table 3-3 and Figure 3-1) reached, the lining and the brake disc must be replaced.

Table 3-3 Air gap

Designation		PMF 1250	PMF 2500	PMF 5000	PMF 6300
Nominal value air gap (a)	[mm]	0.2 (+0.1 / -0.05)	0.2 (+0.1 / -0.05)	0.2 (+0.1 / -0.05)	0.2 (+0.1 / -0.05)
Air gap (a max.)	[mm]	0.6	0.6	0.6	0.6
Holding torque	[Nm]	2	2	2	2
Screw tightening torque	[Nm]	3	3	3	3

Figure 3-1

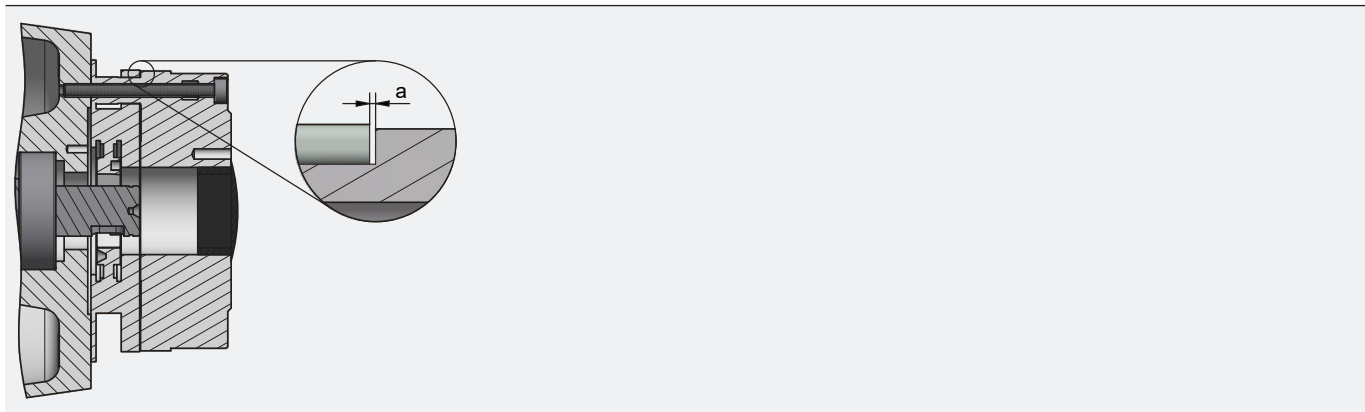

3.2.4 Transmission

The transmission of the motorised trolley has permanent lubrication.

Lubricant.....: Strub HT PU 680

Mixable and compatible with all other brand greases of the same type
(DIN 51502: KP 1 S-20)

Quantity of lubricant: 110 ml

3.2.5 Tightening torques

Torque values for screws of strength class 8.8 per DIN ISO 898:

M 4	M 5	M 6	M 8	M 10	M 12
3.3 Nm	6.5 Nm	10 Nm	24 Nm	48 Nm	83 Nm

3.2.6 Load wheels

The load wheels must be periodically checked for wear and, where necessary, replaced.



If the load wheels show damage, cracks, deformation or corrosion, they must be replaced. If the prescribed dimensions (min.) no longer comply with Table 3-4 and Figure 3-2, the load wheels must also be replaced.

Table 3-4 Load wheel wear values

Designation		PHF/PMF 1250	PHF/PMF 2500	PHF/PMF 5000	PHF/PMF 6300
Load wheel	d [mm]	68	85	105	130
	d min. [mm]	60	77	95	118

Figure 3-2

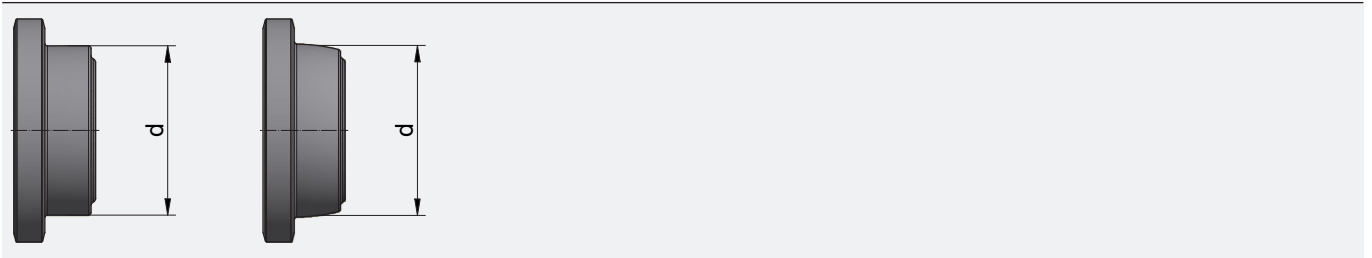

4 Measures for achieving safe operating periods

The statutory and health requirements of the EU regulations stipulate that specific dangers which may arise from fatigue or ageing must be prevented. Accordingly, operators of series trolleys are obliged to determine the actual use. The actual use is recorded as part of the annual inspection by customer service engineers. A general overhaul must be carried out when the theoretical full load cycles are reached, or after no more than 10 years. All checking and the general overhaul itself must be arranged by the operator of the trolley.

The following theoretical operating full load cycles apply throughout the whole service life of trolleys that are categorised per DIN EN 14492-2, depending on the load spectrum:

Classification per DIN EN 14492-2 (ISO 4301-1)	A3 (M3)	A4 (M4)	A5 (M5)	A6 (M6)
Load spectrum	Number of load cycles throughout the whole service life			
Q2 = 0.50	250 000	500 000	1 000 000	2 000 000
Q3 = 0.63	125 000	250 000	500 000	1 000 000
Q4 = 0.80	63 000	125 000	250 000	500 000
Q5 = 1.00	31 500	63 000	125 000	250 000

4.1 Determining the actual use

The actual use depends on the daily operating cycles and the load spectrum. Operating cycles are determined from information provided by the operator or recorded using a meter that counts the number of operating cycles. The load spectrum is determined in accordance with Table 1-1, page 10. With these both values, the annual use can be found in Table 4-1. If an operating data acquisition system (BDE) is used, the actual use can be read out directly by our experts during the annual inspection.



The values periodically calculated or read-off are to be recorded in the inspection pass.

Example:

A trolley with A4 classification is used with the load type "Q4 heavy" (Q = 0.80, see Table 1-1). Use per working day is 60 cycles. According to Table 4-1, this results in a theoretical annual use of 6,300 full load cycles. A theoretical operating period of 19.8 years can thus be derived from the theoretical total service life of 125,000 full load cycles. A general overhaul must be carried out after 10 years at the latest, during which the further use is determined.

Table 4-1 Annual use (208 working days/year)

Number of cycles per working day	<= 15 (15)	<= 30 (30)	<= 60 (60)	<= 120 (120)	<= 240 (240)	<= 480 (480)	<= 960 (960)	<= 1920 (1920)
Load spectrum	Annual use in full load cycles							
Q2 = 0.50	400	800	1 600	3 150	6 300	12 500	25 000	50 000
Q3 = 0.63	800	1 600	3 150	6 300	12 500	25 000	50 000	100 000
Q4 = 0.80	1 600	3 150	6 300	12 500	25 000	50 000	100 000	200 000
Q5 = 1.00	3 150	6 300	12 500	25 000	50 000	100 000	200 000	400 000

4.2 General overhaul

On reaching the theoretical full load cycles (no later than 10 years for recording without BDE), a general overhaul should be performed. This enables the equipment to continue operating safely for a further period of time. Components must be checked or replaced in accordance with Table 4-2. The checking and release for the further use must be done by a specialist company authorised by the manufacturer or by the manufacturer themselves.

The inspector determines:

- What new theoretical full load cycles are possible.
- The max. period until the next general overhaul.

This data should be recorded in the inspection pass.

Table 4-2 General overhaul

Components of trolleys, all types	Check for wear *	Replace
Brake	x	
Motor shaft	x	
Gear teeth		x
Roller bearing		x
Seals		x
Support bolt	x	
Load wheels	x	
Contactator	x	

* replace if worn

4.3 Disposal

If the device can no longer be used, it must be disposed of in an environmentally safe manner. Lubricants, such as oils and greases, must be disposed in accordance with the applicable waste law. Metals and plastics are to be recycled.

5 Annex

5.1 Technical data

Table 5-1 PHF/PMF technical data (three-phase version)

DIN EN (ISO) classification	A3 (M3) 15 C/d (25% duty)	A4 (M4) 30 C/d (30% duty)	A5 (M5) 60 C/d (40% duty)	A6 (M6) 120 C/d (50% duty)	A6 (M6) 120 C/d (50% duty)	Travel speed 50 Hz	Travel speed 60 Hz	Motor type	Dead weight	Main fuse (with hoist, 400 V, slow-blow)
Series	Load capacity [kg]					[m/min]	[m/min]		[kg]	[A]
PHF 1250	1250	1000	800	630	500	-	-	-	-	-
PMF 1250/NF	1250	1000	800	630	500	12/4	14.4/4.8	B9 71 12/4	-	10
PMF 1250/SF	1250	1000	800	630	500	24/6	28.8/7.2	B9 71 8/2	-	10
PMF 1250/N	1250	1000	800	630	500	12	14.4	B9 71 4	-	10
PHF 2500	2500	2000	1600	1250	1000	-	-	-	-	-
PMF 2500/NF	2500	2000	1600	1250	1000	12/4	14.4/4.8	B9 71 12/4	-	10
PMF 2500/SF	2500	2000	1600	1250	1000	24/6	28.8/7.2	B9 71 8/2	-	10
PMF 2500/N	2500	2000	1600	1250	1000	12	14.4	B9 71 4	-	10
PHF 5000	5000	4000	3200	-	-	-	-	-	-	-
PMF 5000/NF	5000	4000	3200	-	-	12/4	14.4/4.8	B9 71 12/4	-	16
PMF 5000/SF	5000	4000	3200	-	-	24/6	28.8/7.2	B9 71 8/2	-	16
PHF 6300	6300	5000	4000	3200	-	-	-	-	-	-
PMF 6300/NF	6300	5000	4000	3200	-	12/4	14.4/4.8	B9 71 12/4	-	16
PMF 6300/SF	6300	5000	4000	3200	-	24/6	28.8/7.2	B9 71 8/2	-	16

Table 5-2 PHFR/PMFR technical data (three-phase version)

DIN EN (ISO) classification	A3 (M3) 15 C/d (25% duty)	A4 (M4) 30 C/d (30% duty)	A5 (M5) 60 C/d (40% duty)	A6 (M6) 120 C/d (50% duty)	A6 (M6) 120 C/d (50% duty)	Travel speed 50 Hz	Travel speed 60 Hz	Motor type	Dead weight	Main fuse (with hoist, 400 V, slow-blow)
Series	Load capacity [kg]					[m/min]	[m/min]		[kg]	[A]
PHFR 1250	630	500	400	320	250	-	-	-	-	-
PMFR 1250/NF	630	500	400	320	250	12/4	14.4/4.8	B9 71 12/4	-	10
PMFR 1250/SF	630	500	400	320	250	24/6	28.8/7.2	B9 71 8/2	-	10
PMFR 1250/N	630	500	400	320	250	12	14.4	B9 71 4	-	10
PHFR 2500	1250	1000	800	630	500	-	-	-	-	-
PMFR 2500/NF	1250	1000	800	630	500	12/4	14.4/4.8	B9 71 12/4	-	10
PMFR 2500/SF	1250	1000	800	630	500	24/6	28.8/7.2	B9 71 8/2	-	10
PMFR 2500/N	1250	1000	800	630	500	12	14.4	B9 71 4	-	10

Table 5-3 PMF FU technical data (three-phase version)

DIN EN (ISO) classification	A3 (M3) 15 C/d (25% duty)	A4 (M4) 30 C/d (30% duty)	A5 (M5) 60 C/d (40% duty)	A6 (M6) 120 C/d (50% duty)	A6 (M6) 120 C/d (50% duty)	Travel speed 50 Hz	Travel speed 60 Hz	Motor type	Dead weight	Main fuse (with hoist, 400 V, slow-blow)
Series	Load capacity [kg]					[m/min]	[m/min]		[kg]	[A]
PMF 1250/N FU	1250	1000	800	630	500	12	3.6/20	B9 71 4	-	10
PMF 1250/S FU	1250	1000	800	630	500	20	6/30	B9 71 4	-	10
PMF 2500/N FU	2500	2000	1600	1250	1000	12	3.6/20	B9 71 4	-	10
PMF 2500/S FU	2500	2000	1600	1250	1000	20	6/30	B9 71 4	-	10
PMF 5000/N FU	5000	4000	3200	-	-	12	3.6/20	B9 71 4	-	16
PMF 6300/N FU	6300	5000	4000	3200	-	12	3.6/20	B9 71 4	-	16

Table 5-4 PMFR FU technical data (three-phase version)

DIN EN (ISO) classification	A3 (M3) 15 C/d (25% duty)	A4 (M4) 30 C/d (30% duty)	A5 (M5) 60 C/d (40% duty)	A6 (M6) 120 C/d (50% duty)	A6 (M6) 120 C/d (50% duty)	Travel speed 50 Hz	Travel speed 60 Hz	Motor type	Dead weight	Main fuse (with hoist, 400 V, slow-blow)
Series	Load capacity [kg]					[m/min]	[m/min]		[kg]	[A]
PMFR 1250/N FU	630	500	400	320	250	12	3.6/20	B9 71 4	-	10
PMFR 1250/S FU	630	500	400	320	250	20	6/30	B9 71 4	-	10
PMFR 2500/N FU	1250	1000	800	630	500	12	3.6/20	B9 71 4	-	10
PMFR 2500/S FU	1250	1000	800	630	500	20	6/30	B9 71 4	-	10

Table 5-5 PMF technical data (single-phase version)

DIN EN (ISO) classification	A3 (M3) 15 C/d (25% duty)	A4 (M4) 30 C/d (30% duty)	A5 (M5) 60 C/d (40% duty)	A6 (M6) 120 C/d (50% duty)	A6 (M6) 120 C/d (50% duty)	Travel speed 50 Hz	Travel speed 60 Hz	Motor type	Dead weight	Main fuse (with hoist, 230 V, slow-blow)
Series	Load capacity [kg]					[m/min]	[m/min]		[kg]	[A]
PMF 1250/N 1Ph	1250	1000	800	630	500	12	14.4	B9 71 4	-	16
PMF 2500/N 1Ph	2500	2000	1600	1250	1000	12	14.4	B9 71 4	-	16

Table 5-6 PMFR technical data (single-phase version)

DIN EN (ISO) classification	A3 (M3) 15 C/d (25% duty)	A4 (M4) 30 C/d (30% duty)	A5 (M5) 60 C/d (40% duty)	A6 (M6) 120 C/d (50% duty)	A6 (M6) 120 C/d (50% duty)	Travel speed 50 Hz	Travel speed 60 Hz	Motor type	Dead weight	Main fuse (with hoist, 230 V, slow-blow)
Series	Load capacity [kg]					[m/min]	[m/min]		[kg]	[A]
PMFR 1250/N 1Ph	630	500	400	320	250	12	14.4	B9 71 4	-	16
PMFR 2500/N 1Ph	1250	1000	800	630	500	12	14.4	B9 71 4	-	16

Table 5-7 Support bolt technical data

Series	Number of support bolts	Support bolt length [mm]	Support bolt diameter [mm]	Flange width range [mm]
PHF/PMF 1250	1	186	32	70 - 140
PHF/PMF 1250	1	286	32	70 - 240
PHF/PMF 2500	1	258	42	88 - 200
PHF/PMF 2500	1	358	42	88 - 300
PHF/PMF 5000	2	368	40	91 - 300
PHF/PMF 6300	2	392	45	91 - 300

5.2 Electrical parameters

Table 5-8 PMF electrical parameters (three-phase version)

Series	Motor type	No. of poles	P_N [kW]	n_N [1/min]	min. / max. currents and start-up current							
					3 x 400 V, 50 Hz				3 x 230 V, 50 Hz			
					I_{N400} [A]		$I_{max.}$ [A]	$\cos \phi_{iN}$	I_{N230} [A]		$I_{max.}$ [A]	$\cos \phi_{iN}$
PMF	B9 71 12/4	12	0.045	410	0.75		0.9	0.56	1.2		1.4	0.56
		4	0.15	1340	0.65		0.8	0.78	1.0		1.2	0.78
PMF	B9 71 8/2	8	0.075	665	0.9		1.1	0.54	1.6		1.8	0.54
		2	0.3	2745	1.0		1.2	0.74	1.8		2.0	0.74
PMF	B9 71 4	4	0.25	1410	0.8		1.0	0.82	1.2		1.4	0.82

Table 5-9 PMF electrical parameters (three-phase version)

Series	Motor type	No. of poles	P_N [kW]	n_N [1/min]	min. / max. currents and start-up current							
					3 x 460 V, 60 Hz							
					I_{N460} [A]		$I_{max.}$ [A]	$\cos \phi_{iN}$				
PMF	B9 71 12/4	12	0.054	490	0.75		0.9	0.56				
		4	0.18	1610	0.65		0.8	0.78				
PMF	B9 71 8/2	8	0.09	815	0.9		1.1	0.54				
		2	0.36	3345	1.0		1.2	0.74				
PMF	B9 71 4	4	0.3	1690	0.8		1.0	0.82				

Table 5-10 PMF electrical parameters (three-phase version)

Series	Motor type	No. of poles	P_N [kW]	n_N [1/min]	min. / max. currents and start-up current							
					3 x 230 V, 60 Hz				3 x 575 V, 60 Hz			
					I_{N230} [A]		$I_{max.}$ [A]	$\cos \phi_{iN}$	I_{N575} [A]		$I_{max.}$ [A]	$\cos \phi_{iN}$
PMF	B9 71 12/4	12	0.054	490	1.5		1.7	0.56	0.6		0.8	0.56
		4	0.18	1610	1.3		1.5	0.78	0.5		0.7	0.78
PMF	B9 71 8/2	8	0.09	815	1.7		1.9	0.54	0.8		1.0	0.54
		2	0.36	3345	2.1		2.3	0.74	0.9		1.1	0.74
PMF	B9 71 4	4	0.3	1690	1.7		1.9	0.82	0.6		0.8	0.82

Table 5-11 PMF electrical parameters (single-phase version)

Series	Motor type	No. of poles	P_N [kW]	n_N [1/min]	min. / max. currents and start-up current									
					1 x 115 V, 50 Hz					1 x 230 V, 50 Hz				
					$I_{N\ 115}$ [A]		$I_{max.}$ [A]		$\cos\ \phi_{i_N}$	$I_{N\ 230}$ [A]		$I_{max.}$ [A]		$\cos\ \phi_{i_N}$
PMF	B9 71 4	4	0.25	1410	2.2		2.4		0.82	1.0		1.2		0.82

Table 5-12 PMF electrical parameters (single-phase version)

Series	Motor type	No. of poles	P_N [kW]	n_N [1/min]	min. / max. currents and start-up current									
					1 x 115 V, 60 Hz					1 x 230 V, 60 Hz				
					$I_{N\ 115}$ [A]		$I_{max.}$ [A]		$\cos\ \phi_{i_N}$	$I_{N\ 230}$ [A]		$I_{max.}$ [A]		$\cos\ \phi_{i_N}$
PMF	B9 71 4	4	0.3	1690	3.9		4.1		0.82	1.0		1.2		0.82

5.3 EC Declaration of Conformity

Declaration for a machinery in accordance with the EU directives 2006/42/EC, Annex II A, 2014/30/EU, Annex I and 2014/35/EU, Annex III



We,

PLANETA-Hebetechnik GmbH, Resser Straße 17, D-44653 Herne

hereby declare that the machinery

trolley, series
with a load capacity of
serial number range

PHF, PMF
250 kg to 6300 kg
1000001 to 2000000

developed for the manual or electrical movement of loads, meets the essential requirements of the following EC directives, insofar as applicable to the scope of the delivery, in standard production form including load control, from the 2020 model year:

EC Machinery Directive	2006/42/EG
EC Directive on Electromagnetic Compatibility	2014/30/EU
EC Low Voltage Directive	2014/35/EU

Harmonised standards applied:

DIN EN ISO 13849-1	Safety-related parts of control systems; Part 1: General principles for design
DIN EN 14492-2	Cranes, power driven winches and hoists; Part 2: Power driven hoists
DIN EN 60204-32	Electrical equipment of machines; Part 32: Requirements for hoisting machines

Authorised to compile relevant technical documentation:
PLANETA-Hebetechnik GmbH, Resser Straße 17, D-44653 Herne

Herne, 06.05.2020

PLANETA-Hebetechnik GmbH

Dipl.-Ök. Christian P. Klawitter
Geschäftsführer

The completion, installation and start-up as per instruction manual is documented in the inspection pass.

5.4 EC Declaration of incorporation

Declaration for the incorporation of an partly completed machinery in accordance with the EU directives 2006/42/EC, Annex II B, 2014/30/EU, Annex I and 2014/35/EU, Annex III



We,

PLANETA-Hebetechnik GmbH, Resser Straße 17, D-44653 Herne

hereby declare that the partly completed machinery

trolley, series	PHF, PMF
with a load capacity of	250 kg to 6300 kg
serial number range	1000001 to 2000000

developed for the manual or electrical movement of loads and intended to be integrated in a machine, meets the essential requirements of the following EC directives, insofar as applicable to the scope of the delivery, in standard production form including load control, from the 2020 model year:

EC Machinery Directive	2006/42/EG
EC Directive on Electromagnetic Compatibility	2014/30/EU
EC Low Voltage Directive	2014/35/EU

We also declare that the technical documentation has been compiled in accordance with Annex VII, Part B of Directive 2006/42/EC. We undertake to submit the specific documents relating to the trolley to national authorities on receipt of a reasonable request. The information will be supplied by electronic means.

Harmonised standards applied:

DIN EN ISO 13849-1	Safety-related parts of control systems; Part 1: General principles for design
DIN EN 14492-2	Cranes, power driven winches and hoists; Part 2: Power driven hoists
DIN EN 60204-32	Electrical equipment of machines; Part 32: Requirements for hoisting machines

This declaration refers only to the trolley. Start-up is prohibited until it has been proven that the entire system into which the trolley is integrated corresponds with the above EC Directives.

Authorised to compile relevant technical documentation:
PLANETA-Hebetechnik GmbH, Resser Straße 17, D-44653 Herne

Herne, 06.05.2020

PLANETA-Hebetechnik GmbH

Dipl.-Ök. Christian P. Klawitter
Geschäftsführer

The completion, installation and start-up as per instruction manual is documented in the inspection pass.

