

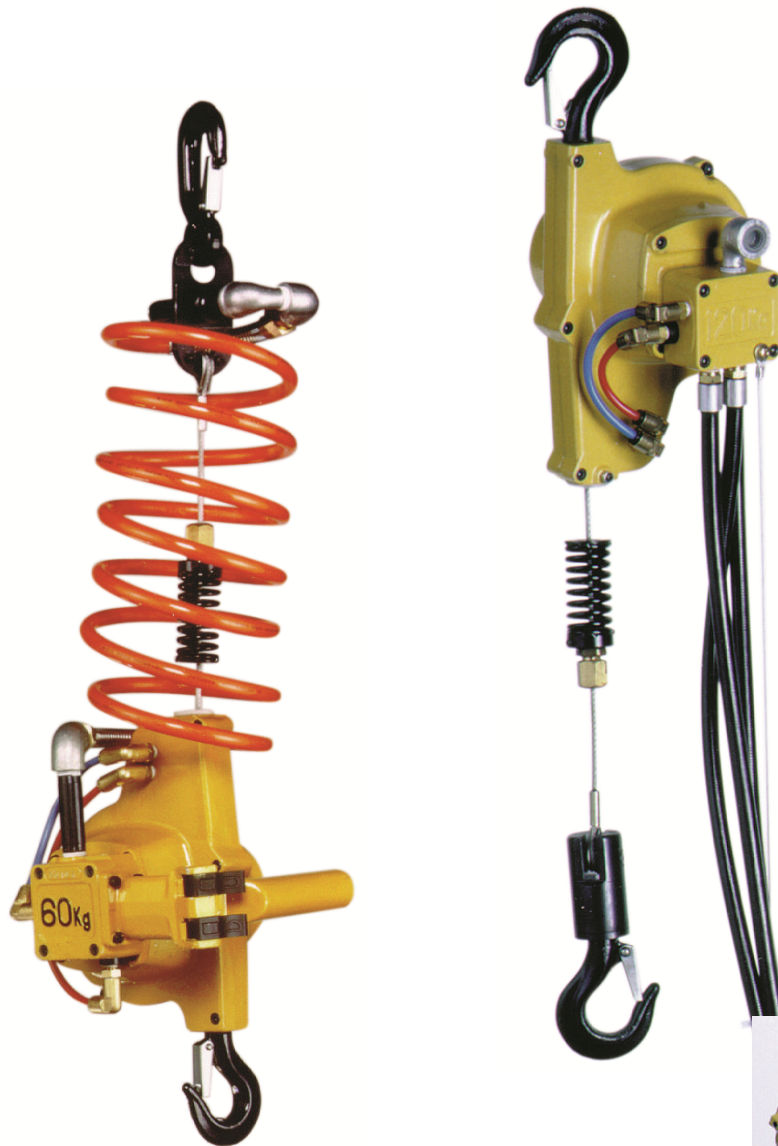

PLANETA

Lifting without limits

INSTRUCTION MANUAL AIR HOIST



**EHW-60
EHW-60R
EHW-120
EHW-120R**



CONTENTS

1. Safety Instructions	1
2. Specifications	5
3. Checks and Instructions before Installation	5
3.1 Checks of the Product	5
3.2 Instructions on Working Conditions.....	5
4. Installation	6
4.1 Installation	6
4.2 Before Air Connection	6
5. Checks after Installation and Test Run	7
5. 1 Check of Hoisting Operation.....	7
5. 2 Check of the Preventive Device against Reverse Winding (Overlowering Limit Switch) ...	7
5. 3 Check of the Lifting Height	8
5. 4 Load Test	8
6. Checks before Operation - At the beginning of each shift	9
6. 1 Check before Start up	9
6. 2 Check by Idling Operation	9
6. 3 Check by Load Operation	9
7. Periodic Inspections.....	10
8. Maintenance and Inspection	11
8. 1 Lubrication.....	11
8. 2 Inspection	12
8. 3 Storing the Hoist	16
8. 4 Troubleshooting	17
9. Brake Adjustment.....	18
10. Disassembly and Reassembly	18
10. 1 Procedures of Disassembly	19
10. 2 Reassembly	20
11. Parts List	26
• Disassembly Drawing of EHW-60 and EHW-120	28
• Disassembly Drawing of EHW-60R and EHW-120R	30

1. Safety Instructions

If the hoist is not used correctly, a serious accident may occur, such as dropping the load. For correct use, carefully read this manual before installation, operation, maintenance or inspection.

Have full knowledge of equipments, safety information and instructions before using the hoist.

* After reading, keep this manual where hoist users can access easily.

1.1 General Instructions

WARNING

- Never use the hoist for lifting or lowering people.
Never lift a load near people nor carry a load over people.
- Before installing, operating, maintaining or inspecting the hoist, carefully read and understand all of the instructions in this manual in order to avoid accidents as a consequence of incorrect handling.
- Keep this manual available for all of the people who will install, operate or maintain the hoist.
- Always check the supporting member from which the hoist is suspended is strong enough to support the weight of the hoist plus the weight of the rated load, etc.
The customer has the responsibility for this.

1.2 Instructions for Safe Operation

If there is any conflict between the instructions in this manual and safety rules of your company, give priority to ones which are more strict than others.

1.2.1 General Handling

WARNING

- Never operate the hoist unless the contents of this manual and caution plate (warning label) are completely known.
- Never operate the hoist nor sling a load unless you were trained in safety rules and in operating manner of the hoist. Never allow untrained persons to do so.
- Never remove or deface any name plates, caution plates or warning labels which are attached to the hoist.
- Always check the hoist before each shift, and inspect it periodically.
- Never operate the hoist if you are not physically fit to do so.
The operator must have good hearing, vision and depth perception.
- When any instruction signs put on the push button switches such as "EQUIPMENT BEING INSPECTED" or "DO NOT RUN", never operate the hoist until the sign is removed by the designated person.

1. 2. 2 Installation

WARNING

- Always employ specialists or well trained persons for installation.
- Never install the hoist in any environments which is out of specifications.
For example, the hoist should not be exposed to rain or water.
- Always install stoppers at the end of the rails for travelling or traversing.
- Always check the supporting member for the hoist has enough strength.
- Make the hoist able to swing freely by using the top hook or the fitting.
* Never fix the hoist.

CAUTION

- * Never operate the hoist when the hoist is placed on the floor.
* Never operate the hoist with the wire rope slackened. Only operate the hoist when it is hanging.

1. 2. 3 Air Pressure

WARNING

- Operate the hoist within a working air pressure range of 0.4-0.6 MPa {4-6 kgf/cni, 60-85psi} .
If the air pressure is less than 0.4 MPa {4kgf/cni, 60psi}, the preventive device against reverse winding (overlowering limit switch) will not work.

1. 2. 4 Operation and Handling

WARNING

- Never lift a load greater than the rated capacity of the hoist.
The rated load is marked on the hoist body.
- Never stand on a suspended load.
Never use the hoist for lifting, lowering or transporting people.
- Always stand clear of the load.
Never walk under a suspended load, and keep out of its area of projection.
Never place hands, feet, etc., under or between suspended loads.
- Never operate the hoist when anyone is in the travelling area of the load.
- Always check there are no objects in the way of the load or the load hook when moving the hoist.
- Never carry a load over people.
- Never leave a load suspended for any extended period.
- Always pay attention to the load at all times when operating the hoist.
- Never swing the load or the load hook when moving the hoist.
- Never use the preventive device against reverse winding (overlowering limit switch) as a means of stopping the hoist. It is for emergency stop only.
Always stop the hoist before the buffer spring collides with the hoist body.
It is for emergency only.

- Never pull a load at an angle.
 - Never lift a load when the load hook is not over the load's center of gravity.
 - * Always move the hoist over the load's center of gravity before lifting.
- Never allow the wire rope to touch structures having a sharp edge.
- Never use the wire rope of the hoist as a sling.
- Never do earth lifting (lifting locked loads).
- Never turn over a suspended load.
 - * Always employ special equipments in case of turn over work.
- Always check movement of the push button switches before operation.
 - Never operate the hoist if the push button switches do not move smoothly.
- Stop the hoist immediately when up /down operations are contrary to the indications marked on the push button switches.
- Always check operation of the brake before using the hoist.
 - Never use the hoist if the brake dose not work weil.
- Never operate the hoist when damaged or abnormal sound / vibration occurs.
- Never operate the hoist with the wire rope in any of the following conditions:
 - Ⓒ Kinked, deformed or corroded.
 - Ⓓ The number of broken wires or the reduction of diameter reaches the service limit.
- Never perform cutting work on a load suspended by the hoist.
- Never perform electrowelding work on a load suspended by the hoist.
- Never use the wire rope of the hoist as a ground for welding.
- Never attach a welding electrode to the wire rope of the hoist.
- Never lift any single load with 2 or more hoists.
- Never lock the push button switches.
 - * The hoist must be operated by the operator himself /herself at all times.
- When moving a load with a plain trolley, never push the wire rope but push the load itself. Never pull the load.

CAUTION

- Never use the hook with a damaged or malfunctioning hook latch.
- Always operate the hoist carefully during lifting and lowering Operations.
 - Never start, stop or reverse the hoist suddenly.
- Never allow the suspended load to touch the nearby structure or power lines, etc.
- Never jerk the hose of the push button switches nor catch it on the nearby structure.
- Never allow the hoist or trolley to collide with the 1-beam stopper or the structure.
- Always check the load hook can swivel smoothly before operating the hoist.
- Always position the slings at the center of the load hook.
- When starting to lift, stop the hoist once as the wire rope becomes tensioned.
 - * Never jerk the hoist. Carefully take up the slackened wire rope.
- Always check the load-lifting height of the hoist is enough for required work.

1. 2. 5 Maintenance, Inspection and Alterations

WARNING

- Never alter the hoist or its accessories.
- Always use genuine parts for replacement.
- Always shut off the air supply before carrying out maintenance, inspection or repair.
- Always employ specialists or well trained persons for maintenance, inspection and repair.
- Always remove the load from the hoist before maintenance, inspection or repair.
- Always disassemble the hoist on the floor.
- If any problems are detected during maintenance or inspection, never use the hoist but correct and repair the problems immediately.
- Periodically, inspect the hoist thoroughly and replace any worn or damaged parts.
- Stretched, worn or damaged hooks should be discarded.
Never attempt to repair it, just replace it with a new hook.
- Always put up an instruction sign ("EQUIPMENT BEING INSPECTED", "DO NOT OPEN THE VALVE", etc.) before carrying out maintenance, inspection or repair.
- Never do anything if you have any questions about the hoist, please do not hesitate to contact your dealer or us.

CAUTION

- Follow the lubrication instructions.
- Never operate the hoist without lubricator and filter.
- Always hang the hoist when carrying out test run after maintenance or repair.
 - * Never operate the hoist with the wire rope slackened.

2. Specifications

Model	Rated load kg	Lift m	Airpressure MPa lkgf/cm ² f	Lifting speed m/min	Air consumption m ³ /min[normal]	Air inlet	Mass kg
EHW-60	60	1.9	0.4 14f	18.5	0.55	R 3/8	9.2
			0.5 15f	22.5	0.7		
			0.6 16f	26.0	0.88		
EHW-60R	60	1.9	0.4 14f	18.5	0.55	Re 3/8	9.5
			0.5 15f	22.5	0.7		
			0.6 16f	26.0	0.88		
EHW-120	120	1.9	0.4 14f	11.0	0.59	R 3/8	9.4
			0.5 15f	13.5	0.75		
			0.6 16f	16.0	0.93		
EHW-120R	120	1.9	0.4 14f	11.0	0.59	Re 3/8	9.7
			0.5 15f	13.5	0.75		
			0.6 16f	16.0	0.93		

Working conditions

Application area Indoor and normal atmospheric conditions

Temperature range : -1 00C to +500C

3. Checks and Instructions before Installation

3.1 Checks of the Product

- Check the delivered hoist is what you ordered (check the name plate).
- Check there was no damage or deformation on the hoist during transportation.
- Check the pressure of the available air supply corresponds to the working air pressure of the hoist.

3.2 Instructions on Working Conditions

WARNING

- Never use the hoist at a temperature below -100C or above +50°C,

CAUTION

- Do not install and leave the hoist outdoors.
If it is necessary to use the hoist outdoors, always make a shelter with a roof for housing the hoist.
- Under hostile environments such as high temperatures, high humidity, acidic, corrosive and /or extremely dusty atmospheric conditions, the mechanical parts of the hoist may be seriously damaged (for example, corroded).
Therefore, frequently check the hoist is maintained in normal conditions at all times.

4. Installation

4.1 Installation

WARNING

Always check the supporting member from which the hoist is suspended is strong enough to support the weight of the hoist plus the weight of the rated load, etc. The customer has the responsibility for this.

CAUTION

Only operate the hoist when it is hanging.
Never operate the hoist when the hoist is placed on the floor.
If operated, irregular winding occurs, causing damage to the wire rope.

Make certain the hoist is properly installed.

A little extra time and effort in doing so can contribute a lot toward preventing accidents and helping you get the best service possible.

The supporting member for the hoist should have successfully passed an inspection for the applicable safety standard.

- Check the top hook is correctly rigged onto the supporting member and the hook latch is correctly closed.
- Never use a supporting member that suspends the hoist at an angle.

4.2 Before Air Connection

WARNING

The hoist is designed to operate within a working air pressure range of 0.4,.....0.6 MPa {4,.....6kgf/cm, 60---BSpsi}.

- Always keep the working air pressure no greater than 0.6 MPa {6kgf/cm}.
If necessary, use an air regulator for reducing air pressure.
- Always keep the working air pressure no less than 0.4 MPa {4kgf/cni}.
If the air pressure is less than 0.4 MPa {4kgf/cni}, the preventive device against reverse winding which consists of an air pilot valve will not work.

- Check sufficient air can be supplied to the operating area of the hoist.

Compare the air supply from the compressor to the air consumption of the hoist.

(See Chapter 2 "Specifications" .)

For a pipe of excessively small diameter or of great length, the pressure drop can become large enough to prevent the specified performance.

- Use an air hose whose inside diameter is at least 9.5 mm (3/8 in.).
- Before connecting the air hose or pipe to the hoist, be sure to flush or blow out with air to prevent the invasion of foreign matter (dust, etc.) into the air motor.
- Compressed air supplied to the hoist should be free from moisture or foreign matter. Install an air filter to eliminate them from air supply.
- Install a lubricator to feed lubricant to the air motor. See Chapter 8, Section 8. 1 "Lubrication". (Never operate the hoist without lubricant.)
- Connect the air filter, regulator and lubricator as close to the hoist as possible.
- When the air hose is connected to the hoist, pour about 10 drops of lubricant into the connecting port of the hoist. See Chapter 8, Section 8. 1 "(3) Recommended Lubricants".
- Install a dump valve (drain valve) at the lowest point in the piping.

5. Checks after Installation and Test Run

5.1 Check of Hoisting Operation

Always keep the working air pressure no less than 0.4 MPa (4kgf/cm², 60psil).

At the initial operation, repeat up / down operations several times at low speed, then go to the full-speed operation.

Adjust the speed by Controlling the pushing force on the push buttons.

At this point, check the lubricator is feeding lubricant to the air motor.

See Chapter 8, Section 8. 1 "Lubrication".

Check the indications marked on the push buttons correctly show the actual directions of up / down operations.

5.2 Check of the Preventive Device against Reverse Winding (Overlowering Limit Switch) -See Fig. 1

Slowly operate the hoist in the lowering direction while paying attention to the air from the air exhaust hole.

Check the preventive device against reverse winding works at the lower limit. (Check the hoist stops when the wire rope extends 1.9m).

If the hoist does not stop within 100 mm after starting air exhaust, stop operation immediately.

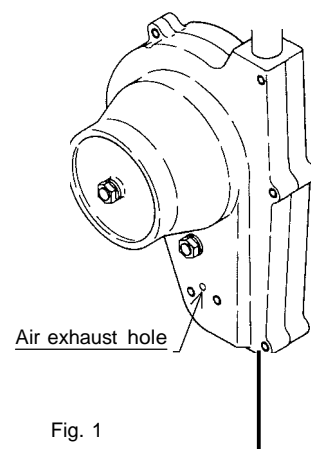

Fig. 1

5.3 Check of the Lifting Height

WARNING

The preventive device against reverse winding (overlowering limit switch) and the buffer spring are for emergency only.

Never use them for usual operations.

If the buffer spring is frequently used, the wire rope will be damaged and the suspended load may drop, causing serious danger.

Check the preventive device against reverse winding dose not work and the buffer spring dose not collide with the hoist body during required work.

If do, change the mounting height of the hoist.

5.4 Load Test

- Lift the rated load a few inches off the floor and check ability of the brake to stop and hold the load without excessive dritt.

In case of using the hoist with the trolley, traverse the trolley over the entire length of 1-beam with the rated load suspended a few inches off the floor.

Check the condition of 1-beam and the length of the air hose.

- Lift 125 % of the rated load and check the operation.

This test should be performed for the safety check concerning the hoist, 1-beam, etc.

6. Checks before Operation- At the beginning of each shift

WARNING

- Always execute the following checks at the beginning of each shift.
- If a malfunction occurs during the operation of the hoist, stop operation immediately and take the necessary steps to rectify the problem.
Never operate the hoist if damaged or malfunctioning.
This is a serious hazard and could result in personal injury or death.

6.1 Check before Start up

- (1) Check the wire rope is not kinked, deformed, damaged, or worn.
See Chapter 8, Section 8.2 "(2) Inspection of Wire Rope and Service Limit".
- (2) Check the bottom hook is not stretched or damaged and the hook latch is in the normal position.
- (3) For EHW-60R and EHW-120R, check the bottom hook can swivel smoothly.
- (4) Check the stopper is approx. 65 mm apart from the end of the locking portion of the wire rope. (See Figure in right.)

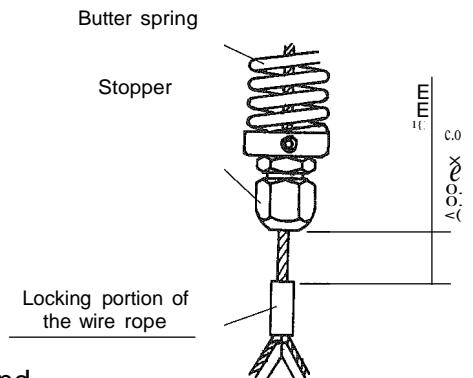

WARNING

If the buffer spring collides with the hoist body while the stopper is in contact with the locking portion of the wire rope, the wire rope will be damaged and the suspended load may drop, causing serious danger.

- (5) Check the trolley wheels track the rails properly and the wheels and rails are not worn.
- (6) Check the lifting sling (suspension fastening) is not damaged or worn.

6.2 Check by Idling Operation

- (1) Check the push button switches can be easily operated and the up / down operations are correct as indicated.
Check hoisting speed can be changed from low to high speed by controlling the pushing force on the push buttons.
- (2) Check the preventive device against reverse winding functions correctly.
See Chapter 5, Section 5.2 "Check of the Preventive Device against Reverse Winding (Overlowering Limit Switch)".
- (3) Check the hoist is not abnormally noisy or vibrating.

6.3 Check by Load Operation

- (1) Lift the rated or near the rated load a few inches off the floor and check ability of the brake to stop and hold the load without excessive dritt.
- (2) Check the hoist is not abnormally noisy or vibrating.

7. Periodic Inspections

WARNING

- Always put up an instruction sign ("EQUIPMENT BEING INSPECTED", "DO NOT RUN", etc.) on the push button switches before carrying out inspections.
- Periodically, inspect the hoist thoroughly and replace any worn or damaged parts.
- Always shut off the air supply before carrying out inspections.
Exceptions are checks or inspections of the push button switches, brake, preventive device against reverse winding, etc., during that the hoist should be operated.

- Preparing a special table for inspection is recommended.

II Monthly Inspection

Inspect the hoist at least once a month. Correct and repair any problems which are detected.

- Required interval for inspection depends on the operating environment, operating frequency and loading conditions of the hoist.

Therefore, make the inspection interval shorter according to your operating condition.

- For inspection items and methods, see Chapter 8, Section 8.2 "Inspection".

II Annual Inspection - Disassembly is required

Completely disassemble the hoist at least once a year for inspection and maintenance.

Correct and repair any problems which are detected.

- Required interval for inspection depends on the operating environment, operating frequency and loading conditions of the hoist.

Therefore, make the inspection interval shorter according to your operating condition.

- For inspection items and methods, see Chapter 8, Section 8.2 "Inspection".

II Service Limit of Parts

If any part is found to be worn beyond its service limit in the monthly, annual, or other inspections, never reuse it.

8. Maintenance and Inspection

WARNING

- Never alter the hoist or its accessories.
- Always remove the load from the hoist before maintenance, inspection or repair. Exception is a inspection of brake, etc.
- Always put up an instruction sign ("EQUIPMENT BEING INSPECTED", "DO NOT OPEN THE VALVE", etc.) before carrying out maintenance, inspection or repair.
- Always shut off the air supply before carrying out maintenance, inspection, or repair. Exceptions are checks or inspections of the push button switches, brake, preventive device against reverse winding, etc., during that the hoist should be operated.
- Always employ specialists or well trained persons for maintenance, inspection and repair.
- Always disassemble the hoist on the floor.
- Always use genuine parts for replacement.
- Replace any parts damaged or worn beyond its service limit.
- Always execute the load test after disassembling the hoist for maintenance or inspection. See Section 8. 2 "(9) General Operation Inspection".

Always use the hoist correctly for safety and getting the best service.

8.1 Lubrication

(1) Air motor

- To prevent the air motor from dry operation, continuously lubricate using a lubricator.
- Adjust the lubricator so that lubricant is fed at a rate of S drops per 1 m^3 of air during hoist operation.
- Periodically check the oil level in the lubricator, and replenish if necessary. Never allow the oil level to go below the indicated line.
- Periodically remove drain water deposited in the air filter bowl.

WARNING

Always shut off the air supply before putting lubricant in the lubricator.

(2) Reduction Gear Unit

- Periodically put grease into the grease nipple on the casing.
- Required quantity of grease is $5 \text{ } 10 \text{ cm}^3$ ($5 \text{ } 10 \text{ ml}$).
- Determine the lubrication interval according to the operating frequency.
- Lubricate in the no-load condition.
Operate the hoist with no load several times after lubricating.

(3) Recommended Lubricants

The following table shows the recommended lubricants.

Always use the same type or equivalents recommended by the oil manufacturer.

Manufacturer	Airmotor (Lubricator)	Reduction gear cncl. bearing of) reduction gear
Esso	Arox 22 Teresso 32	Beacom EP2
Mobil	Almo Oil No.525	Mobilux EP2
Shell	Tellus Oil C32 Torcula Oil 32	Alvania Grease EP2

- When disassembling, apply lithium saponified molybdenum disulfide grease (Molykote BR2-S, and the like) corresponding to the No. 2 class of NLGI (National Lubrication Grease Institute) to the O-rings for dynamic seal.

8.2 Inspection

(1) Inspection of Hook and Service Limit

WARNING

Never repair the hooks.

Always replace a stretched, worn or damaged hook with new one.

III Inspection on Hook Opening, Cracks and Wear.

If any of the following conditions apply to the inspected hook, never reuse, always replace with new one.

- The hook opening is visibly stretched, or the opening dimension is different from the specified.
- The hook is deformed or cracked.

Carefully check for any bends or cracks on the hook shank.

- Wear on the hook saddle, where the lifting sling (suspension fastening) rests, reaches the service limit.
- The hook latch is damaged or malfunctioning.

–Hook Opening Dimension and Wear Limit

For the hook opening dimension A or C, measure the hook before use as a reference for later inspections.

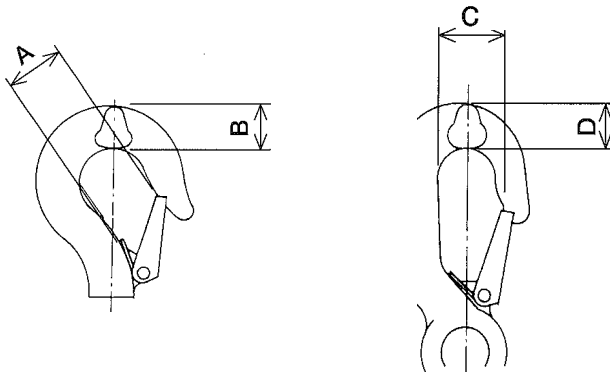

	Standard dimension	Service limit
A	26.0	—
B	19.0	16.9
C	27.5	—
D	18.0	15.9

(2) Inspection of Wire Rope and Service Limit

Operate the hoist in the lowering direction until the preventive device against reverse winding (overlowering limit switch) works. Then inspect the wire rope.

• Never use the wire rope having any one of the following defects.

- Kinked, deformed or corroded.
- The number of broken wires reaches the service limit.
- The reduction of diameter reaches the service limit.

–Wear Limit and Limit of Broken Wires.

The number of broken wires in one lay should be no greater than 10 % of all wires.

And the number of broken wires which are close each other and in the same strand should be no greater than 5 %.

(mm)

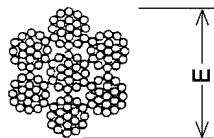

	Standard dimension	Service limit
E	3.18	2.95

Number of all wires	Limit of broken wires	
	in one lay 10%	close each other and in the same strand 5%
133(7X19)	13	7

• Replacement Parts

Always use a manufacturer's replacement wire rope.

Using other wire ropes could cause damage to the preventive device against reverse winding (overlowering limit switch).

(3) Inspection of Brake and Service Limit

Disassemble the brake and inspect the lining and component parts.

For disassembly, see Chapter 10, Section 10. 1 "Procedures of Disassembly".

- Does wear on the lining exceed the service limit ?
- Are Springs (50) decayed, cracked or flawed ?
- Are there any pressed marks or cracks at the engaged part between Brake wheel(32) and Shaft (30) ?
- Is the air exhaust hole® on Brake cylinder (48) open ?
- Are there flaws, deformation or wear on O-rings (49), (53) ?

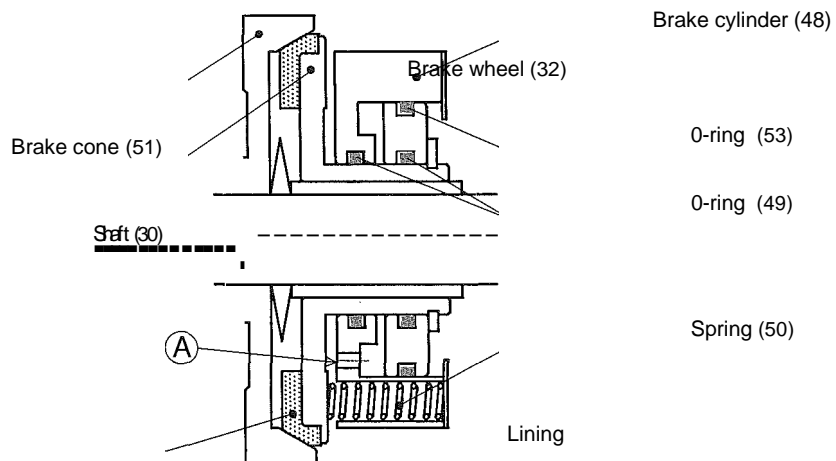

Wear Limit of Lining

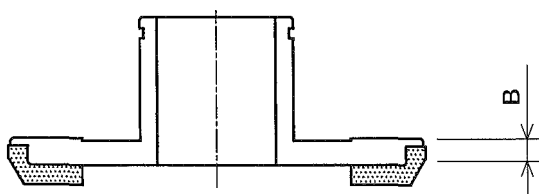

(mm)		
—	Standard dimension	Service limit
B	2.6	2.0

–Replacement Parts

- Always replace Springs (50) whenever Brake cone (51) is replaced.
- Replace all Springs (50) at the same time.

(4) Inspection of Hook Holder

- Is there any deformation or cracks on the hook holder ?
- Are the bolts and set screws loose ?

–For EHW-60R and EHW-120R

- Is the bearing damaged or worn ?
That which does not rotate smoothly (feels rugged when manually rotated) is beyond its service limit.
- Are there any pressed marks, deformation, flaws, cracks or corrosion on the wire rope anchor pin?

(5) Inspection of Casing

- Are there any flaws, cracks, or deformation ?
Carefully check the part where the top hook is attached.
- Are the bolts loose ?

(6) Inspection of Switch and Valve

- Are there any flaws, deformation or wear on the O-rings ?
- Are the springs decayed, cracked or flawed ?
- Is the hose damaged, or is the connection part loose ?
- Do the push buttons correctly return to the neutral position after being pushed ?
- Are the bolts loose ?
- Is the silencer in the handle clogged ?
- Check the pilot valve for the preventive device against reverse winding.
See Valve body(14) in the disassembly drawing (on Page 28 or 30).
Does the pilot valve return quickly when released after pressing the tip of the valve ?

(7) Inspection of Air Motor

- Replace parts which show the following conditions :
 - The vanes are warped (curved), seized or cracked.
Wear on the vanes reaches the service limit.
 - The side face of the rotor is gouged or seized.
 - The vane slot of the rotor is worn beyond the service limit or is narrower than the standard dimension.
 - The rotor is cracked, or the keyway is deformed.
 - There is a visible indent or deformation on the key.
 - The end plate is gouged or seized, or the surface is rough due to wear.
 - Abnormal wear, flaw or corrosion is found on / in the cylinder.
 - The bearings are damaged, worn, or do not rotate smoothly (feels rugged when manually rotated).

||||| Wear Limit of Vane and Rotor

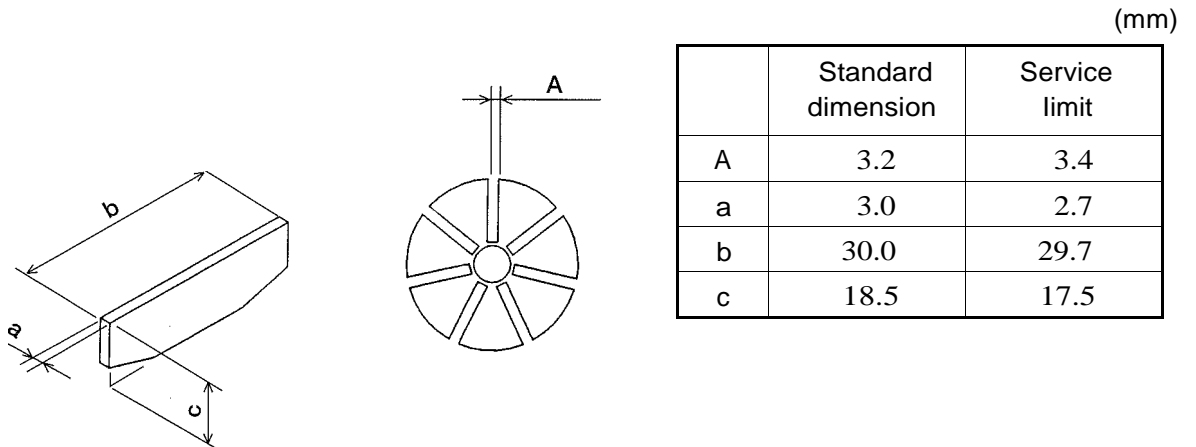

(8) Inspection of Reduction Gear Unit

- Are there any shavings, burrs, marks, or deformation on the keyway or the brake wheel engaging portion of the shaft ?
- Is any part deformed or cracked ?
- Are the bearings damaged or worn ?
Those which do not rotate smoothly (feels rugged when manually rotated) are beyond their service limit.
- The wear limit of the gear on the pitch circle should be within 5 % of the original dimension of tooth thickness.

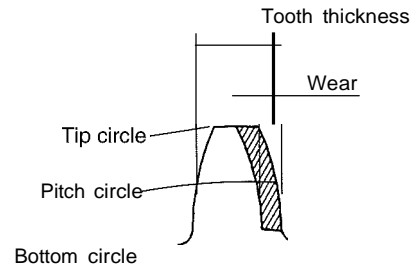

(9) General Operation Inspection

After completing the inspections described in the foregoing sections, reassemble the whole unit according to Chapter 10, Section 10. 2 "Reassembly" and inspect as follows :

Idling

- Check the push button switches can be easily operated and up / down operation are correct as indicated.
- Check hoisting speed can be changed from low to high speed by controlling the pushing force on the push buttons.
- Check the preventive device against reverse winding functions correctly.
See Chapter 5, Section 5. 2 "Check of the Preventive Device against Reverse Winding (Overlowering Limit Switch)".
- Check the hoist is not abnormally noisy or vibrating.

Load Test

- Check for malfunctions while lifting and lowering.
Operate the hoist at least twice through the full lifting range.
- Lift the rated load a few inches off the floor and check ability of the brake to stop and hold the load without excessive dritt.
- Check there is no significant reduction in the hoist performance.
- Check the hoist is not abnormally noisy or vibrating.

8.3 Storing the Hoist

If the hoist is to be stored for a long time, supply rust-proofing oil, for example, "Shell Ensis Fluids SDB", etc., through the air inlet port and run the hoist at low speed for several seconds. Store the hoist in a dry location.

8.4 Troubleshooting

WARNING

If a malfunction occurs during the operation of the hoist, stop operation immediately and take the necessary steps to rectify the problem.

Never operate the hoist if damaged or malfunctioning.

This is a serious hazard and could result in personal injury or death.

CAUTION

Careless repairs can cause damage to the hoist or personal injury.

Therefore, be careful but thorough when making repairs.

The following table shows probable causes and solutions of common malfunctions.

If any malfunctions not shown below happen, please contact your dealer or us.

Maltunetion	Main Causes	Solution
Motor does not run. Slow rotation or no rotation of Motor.	<ul style="list-style-type: none"> • Insufficient air pressure. • Supplied air volume is insufficient. • Inside diarneter of pipe is too srnall. • Powder or dust in Motor. • Vanes have been enlarged due to rnoisture or long ternn storage. • Vanes are burned due to the dry operation. • Vanes are worn or damaged. • O-rings of rmain valve is damaged. • Brake does not release. • Reduction gear : Incorrect assernbly. Or gears, bearings, etc., are worn or damaged. 	<ul style="list-style-type: none"> • Increase air pressure. • Increase cornpressor output. • Replace pipe with a larger inside diarneter. • Clean Motor then Lubricate. Clean air filter and replace filter elernent. • Replace Vanes. Discharge drain water from air filter. Or clean air filter and replace filter elernent. • Clean Motor and polish Vanes. Replace Vanes if required. Supply oil to lubricator or clean lubricator. • Replace Vanes. • Replace O-rings. • Check the damage etc. on O-rings. • Disassernble and check. Replace the worn or damaged parts.
Brake does not work sufficiently.	<ul style="list-style-type: none"> • Lining is worn. • Main valve does not return to the neutral position. 	<ul style="list-style-type: none"> • Replace with new Brake corn. • Check the damage on O-rings and Springs, etc.
Hoist does not run in the lowering direction.	<ul style="list-style-type: none"> • Preventive device against reverse winding works incorrectly. 	<ul style="list-style-type: none"> • Disassernble and check.
Hoist does not run in the lifting direction after preventive device against reverse winding works.	<ul style="list-style-type: none"> • Insufficient air pressure. • Preventive device against reverse winding does not release. 	<ul style="list-style-type: none"> • Increase air pressure. • Remove the load, then try lifting. If lifting cannot be done, disassernble and check.

9. Brake Adjustment (See Fig. 2.)

CAUTION

Always shut off the air supply before carrying out brake adjustment.

The brake has been adjusted before shipping.

But the braking force will decrease because of wear on the lining during operation.

Therefore, the brake should be inspected and readjusted.

Make the readjustment in the following manner :

- ① Loosen the hex. nut.
- ② Tighten the set screw $\frac{1}{6}$ --- $\frac{2}{6}$ turns clockwise.
And lock the set screw with the hex. nut.
- ③ Lift the rated load and repeat up / down operation several times.

Check ability of the brake to stop and hold the load without excessive dritt.

NOTE : If the set screw is over-tightened, the lifting ability of the hoist will decline.

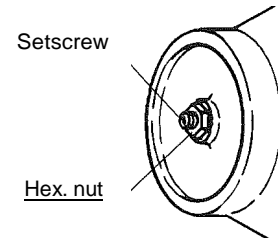

Fig. 2

10. Disassembly and Reassembly

WARNING

- Always shut off the air supply before carrying out disassembly or reassembly.
- Always disassemble or reassemble the hoist on the floor.
- Always employ specialists or well trained persons for disassembly and reassembly.

CAUTION

- Careless work can cause damage to the hoist or personal injury.
Therefore, take care during disassembly and reassembly.
- Before reassembly, thoroughly clean all disassembled parts and check for cracks, flaws, deformation and wear.
- Never use acidic solvents for cleaning.
- Replace any damaged or excessively worn parts.
Also replace burred or damaged screws.

10.1 Procedures of Disassembly

(NOTE)

- Whenever grasping a part in a vice, always use copper-covered vice jaws to protect the surface of the part and help prevent distortion.

Referring to the disassembly drawing (on Page 28 or 30), disassemble the hoist using the following procedure.

When replacing the worn part, only disassemble the necessary part for replacement.

The steps -1) to -5) for MODELS EHW-60 and EHW -120 are different from those for MODELS EHW-60R and EHW-120R.

The step -6) and the rest are the same.

➤ For EHW-60 and EHW-120

- 1) Loosen Setscrew (92), and remove Steel ball (91) and Washer (90).

If Washer (90) does not move, it is unnecessary to remove.

- 2) Loosen Hex. nuts (100) and Cap screws (109).

Remove Hook holders (97) from Wire rope (39).

- 3) Remove Nylon tubes (104), (105).

Pull out Nylon tubes (104), (105) while pushing the collet of Elbow (81). (See Fig. 3.)

- 4) Loosen Cap screws (108) and remove Valve body (70) and Coil hose (103) together.

- 5) Disassemble Valve body part (70).

① Remove Handle (82). Remove Spacers (78), then remove Spools (76) and Springs (75).

② Remove Elbow (81) and Adapter (74).

③ Remove Plug (71) and press out Valve cone (72) to the adapter side.

NOTE: Never hammer Valve cone (72). If hammered, Valve cone (72) will be damaged and cause trouble of the preventive device against reverse winding (overlowering limit switch).

➤ For EHW-60R and EHW-120R

- 1) Loosen Setscrew (94), and remove Steel ball (93) and Washer (92).

If Washer (90) does not move, it is unnecessary to remove.

- 2) Loosen Cap screw (99-10) and remove Pin (99-7).

Remove Bottom Hook compl. (99) from Wire rope (39).

- 3) Remove Nylon tubes (100), (101). (See Fig. 3.)

Pull out Nylon tubes (100), (101) while pushing the collet of Elbow (75).

Remove Valve body (70), Hoses (77) and Valve body (78) together.

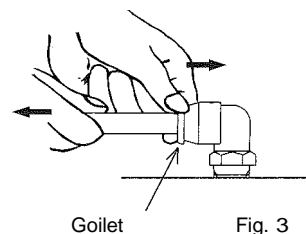

-4) Disassemble Valve body part (70).

- Remove Elbow (75) and Adapter (74).

-Remove Plug (71) and press out Valve cone (72) to the adapter side.

NOTE: Never hammer Valve cone (72). If hammered, Valve cone (72) will be damaged and cause trouble of the preventive device against reverse winding (overlowering limit switch).

-5) Disassemble Valve body part (78).

Remove Handle (83). Remove Spacers (82), then remove Spools (80) and Springs (79).

11) For EHW-60, EHW-120, EHW-60R and EHW-120R

-6) Place the hoist so that Casing (1) faces downward and End plate (69) faces upward.

-7) Remove End plate (69). Remove Cylinder (64) and Rotor (66), then remove Vanes (67) and Key (65).

-8) Loosen Gapscrew (63). Loosen cap screws (61), (62) sequentially by 1/6 turns, and remove Casing (42) from Casing (1).

-9) Remove End plate (43), Brake cylinder (48) and Brake cone (51) together from Casing (42).

-10) Disassemble Brake cylinder part (48).

Ⓒ While pressing Brake cone (51) to the End plate (43) side, loosen Gap screws(55) sequentially by 1/6 turns, and remove Brake cylinder (48).

Ⓓ Remove Retaining ring (54), and remove Brake cone (51).

-11) Remove Drums (36), (40) and Wire rope (39) together from Casing (1).

Remove Drum (40) from Drum (36), and remove Wire rope (39).

-12) Remove Planet shaft (25A or 258), Gear wheels (26), Shaft (30) and Brake wheel (32) together.

-13) Remove Retaining ring (29), remove Pins (28), and remove Gear wheels (26) from Planet shaft.

-14) Loosen Countersunk head cap screw (23) and remove Valve body (14).

-15) Remove Liner (21) from Valve body (14), and remove Valve (16), Valve seat (19) and Spring (15).

10. 2 Reassembly

(NOTE)

- Never use solvents to clean rubber parts, such as O-ring, etc., or plastic parts.
- Whenever grasping a part in a vice, always use copper-covered vice jaws to protect the surface of the part and help prevent distortion.
- Always press on the inner ring of a ball-type bearing when installing the bearing on a shaft.
- Always press on the outer ring of a ball-type bearing when pressing the bearing into a bearing recess.
- Always press against the stamped end of a needle-type bearing when pressing the bearing into a bearing recess.

Reassemble the hoist in reverse order of disassembly and pay attention to the following points :

- 1) Always replace Conical spring washer (12) and Retaining ring (54) with new ones.
- 2) Assembling direction for Retaining ring (See Fig. 4.)
Set up Retaining ring so that the non-chamfered face bears the load.

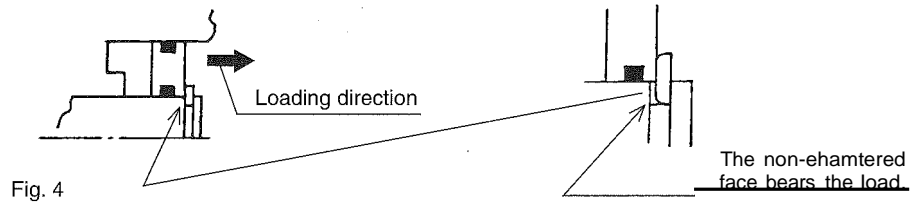

- 3) Be careful grease, etc., does not adhere to Brake lining (10) or the sliding surface of Index wheel (9) and Washer (11) where Brake lining (10) contacts.
After installing Index wheel (9) in Casing (1), check its movement.
Index wheel (9) should not rotate freely.
- 4) Before installing Valve body (14) in Casing (1), check the 0.5 air exhaust hole on Valve body (14) is open and Valve (16) returns quickly when released after pressing the tip of Valve (16). (See Fig. 5.)

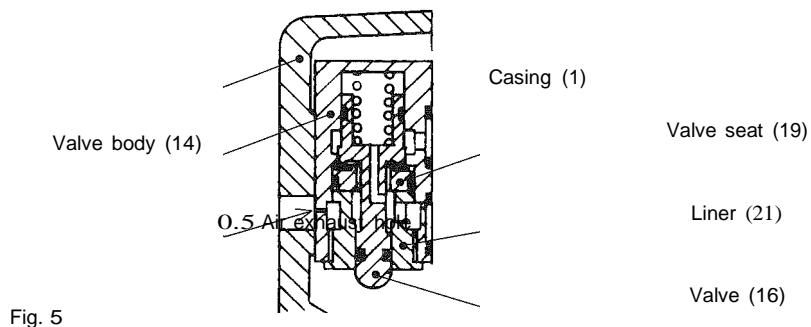

-5) Reduction gear unit

- ① Apply about 3cm (3ml) of grease to 63T internal gear (2).
Also apply grease to Bearing (5).
- ② Assemble Planet shaft (25A or 25B), Gear wheels (26), Shaft (30) and Brake wheel (32).
Then attach Spacer (33) to Shaft (30), and install them into Casing (1).
When assembling, apply about 12cc (12ml) of grease to Gear wheel (26).
NOTE : Be careful grease does not adhere to the inside surface of Brake wheel (32) [the sliding surface where Brake cone (51) contacts].

-6) Drum unit (overlowering detecting portion)

For detecting overlowering, the wire rope anchoring position is very important.

Always pay attention to it when reassembling the hoist.

① Rotate Index wheel (9) and set it as show in Fig. 6.

(At this point, the preventive device against reverse winding will work.)

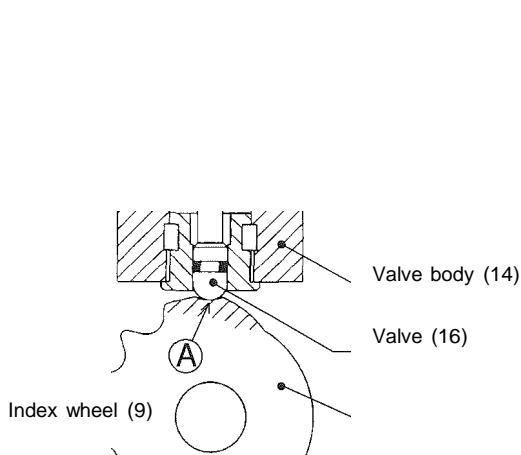

Small recess ① on Index wheel (9) should be in contact with the tip of Valve (16).

Fig. 6

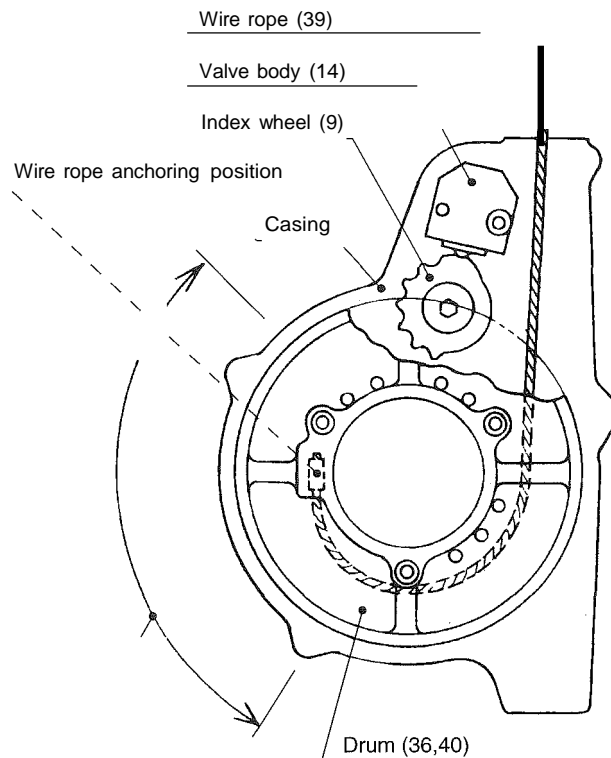

When assembling the drum, the wire rope

anchoring position should be in this area.

Fig.7

② Attach Pin (38) and Wire rope (39) to Drum (36), then mount Drum (40).

③ Apply about 3cm (3ml) of grease to Internal gear (37A or 378).

Also apply grease to the sliding surface of Bearings (5), (44) where the drum contacts.

④ Install the drum into Casing (1) so that the wire rope anchoring position comes in the area shown in Fig. 7.

If the gears do not engage well, rotate Shaft (30) a little.

-7) Brake unit

① Apply grease to O-rings (49), (53) and the grooves of Brake piston (52) and Brake cylinder (48) a little, then install O-rings (49), (53).

Install Brake cone (51) and Brake piston (52) in Brake cylinder (48).

② Degrease the threaded holes of End plate (43) and Cap screws (55) using solvent.

③ Install Steel balls (46) and Set plate (47) to End plate (43).

The oval holes of Set plate (47) should meet Steel balls (46).

④ Install Springs (50) in Brake cylinder (48), and install them to End plate (43).

Apply adhesive to Cap screws (55) and tighten them sequentially by 1/6 turns.

Use Loctite 222 or equivalents for adhesive.

5. Install End plate (43) into Casing (42).

Assembling direction differs depending on the models. See Fig. 8.

NOTE : Be careful grease does not adhere to the lining of Brake cone (51).

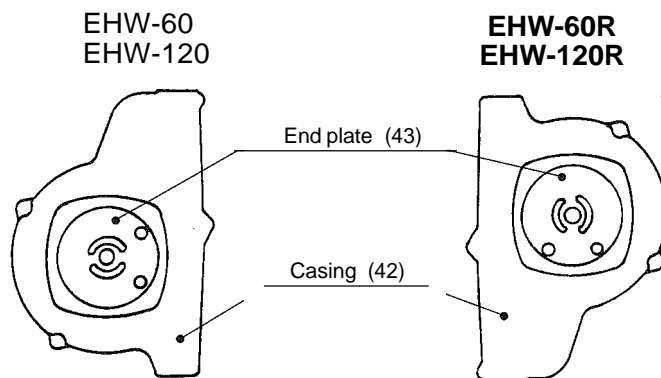

Fig. 8

-8) Install Hook (56) and Washer (60) in Casing (1). Install Casing (42) on Casing (1).

Tighten Cap screws (61), (62) sequentially by 1/6 turns, then tighten Cap screw (63).

-9) Air motor unit

① Install Cylinder (64), Key (65), Rotor (66), and Vanes (67) in this order.

Rotate Cylinder (64) when installing Vanes (67).

② Lubricate Vanes (67) a little. (Use the same lubricant used for the lubricator.)

See Chapter 8, Section 8. 1 "(3) Recommended Lubricants".

-10) Valve body part (70)

① Check there are no flaws on the outer surface of Valve cone (72) and the inner surface of Valve body (70) (the sliding surface where Valve cone (72) contacts).

② Install O-ring (73) to Plug (71), and install them in Valve body (70).

③ Apply grease to the grooves of Valve cone (72) and install Mini Y-packings [for EHW-60 and EHW-120: (110), for EHW-60R and EHW-120R: (105)].

After installing Mini Y-packings, apply grease a little to Mini Y-packings. (See Fig. 9.)

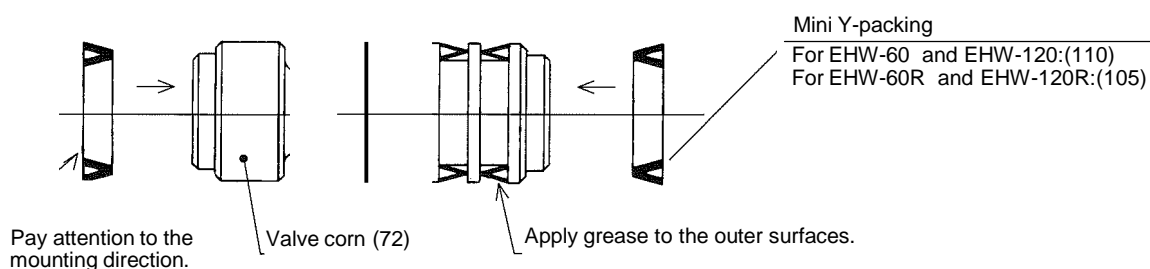

Fig. 9

4. A jig is required when installing Valve cone (72).
(See Fig. 10.)

Attach the jig to Valve body (70), then insert Valve cone (72) into Valve body (70) through the jig and press by hand until Valve cone (72) touches Plug (71). (See Fig. 11.)

NOTE : Before installing Valve cone (72), install Plug (71). If Valve cone (72) is inserted without the jig or pressed by Adapter (74), Mini Y-packing will be damaged.

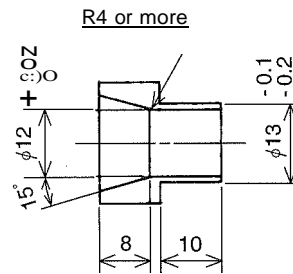

Fig. 10

Dimensions of jig (P2H400115)

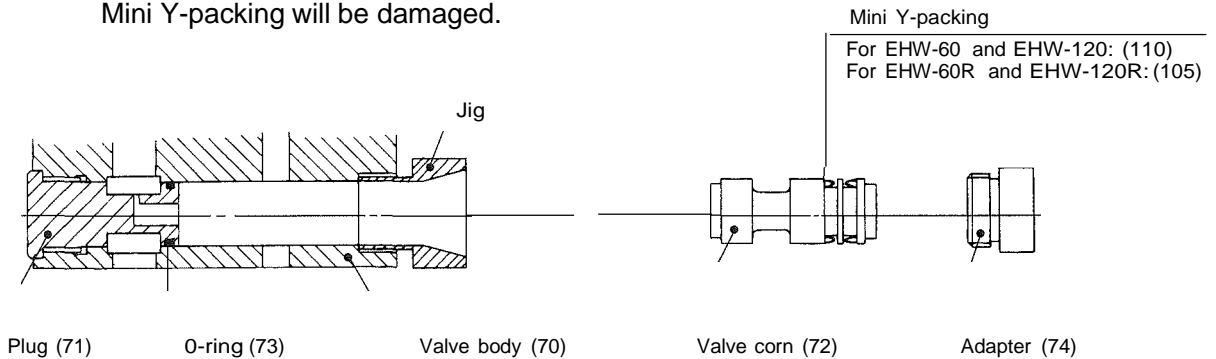

Fig. 11

5. Take off the jig and install Adapter (74).

-11) • For EHW-60 and EHW-120

Install Washer (90) and Steel ball (91). Tighten Setscrew (92) until it touches Steel ball (91). Then fix Setscrew (92) with Hex. nut (13).

• For EHW-60R and EHW-120R

Install Washer (92) and Steel ball (93). Tighten Setscrew (94) until it touches Steel ball (93). Then fix Setscrew (94) with Hex. nut (13).

-12) Stopper [For EHW-60 and EHW-120: (96), For EHW-60R and EHW-120R: (98)]

Set Stopper at approx. 65mm apart from the end of the locking portion of Wire rope (39). (See Fig. 12.)

Place Wire rope (39) in the groove of Stopper and tighten Stopper with a torque of 59 64 N·m 16.0 6.5 kgf·m.

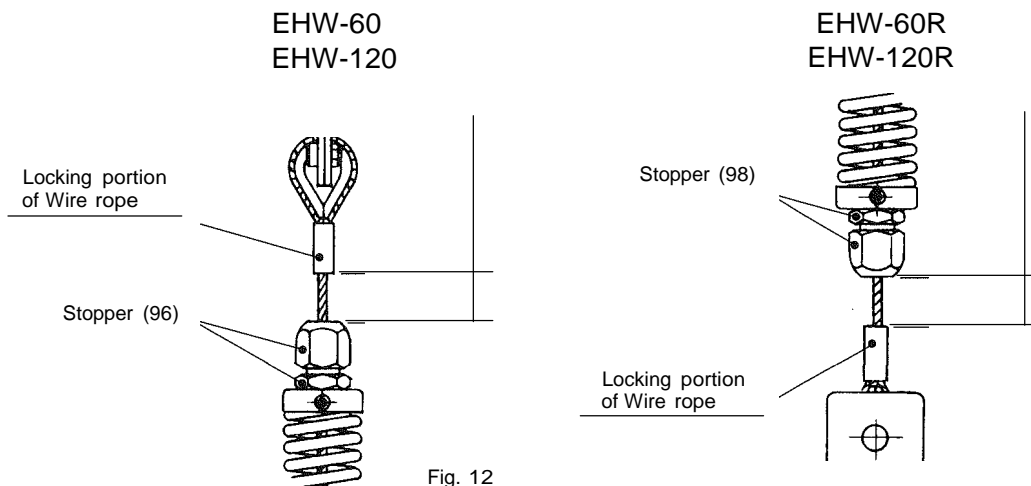

Fig. 12

-13) Checks after reassembly

- ① After completing reassembly, hang the hoist using a crane, etc. and connect the temporary piping.

Keep the air pressure no less than 0.4 MPa
14kgf/crrf, 60psif.

When connecting the temporary piping, the air comes out continuously from the air exhaust hole.

If the air does not come out, stop operation immediately and check the overlowering detecting portion in the drum unit.

- ② At first, operate the hoist in the lifting direction.

In this stage, never operate the hoist in the lowering direction.

Retract the whole wire rope while tensing the wire rope.

The air from the air exhaust hole will stop when the wire rope is retracted approx. 400 mm.

If the air does not stop, stop operation immediately, and check Pin (38) is installed correctly and

Valve seat (19) is sealed properly.

- ③ Operate the hoist in the lowering direction and check the preventive device against reverse winding functions correctly.

At the first time, operate the hoist in the lowering direction slowly while paying attention to the air from the air exhaust hole.

If the hoist does not stop within 100 mm after starting air exhaust, stop operation immediately and check the air pressure and Valve cone (72).

At the second time, check again with normal speed.

- ④ Repeat up / down operation several times at low speed, then go to the full speed operation.

- ⑤ Lift the rated load a few inches *oft* the floor and check ability of the brake to stop and hold the load without excessive dritt.

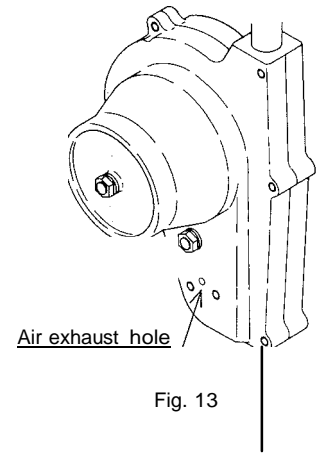

11. Parts list

（ Remarks when purchasing parts ）

- Specify the part No., part name and model name of the hoist.
- State SER. No. (product No.) clearly if attached.
- Parts without a part number cannot be supplied individually.
Please purchase a set or complete unit.

•How to read parts list

Ref No.	Part No.	Quantity		Description
		EHW-60	EHW-120	
	LHP000073	1		Casing set
1	P2H100019c	1	1	-Casing
2	P2H300141a	1	1	— 63T internal gear
3	KA42410412	1	1	-Spring pin
4	KA42419812	1	1	-Spring pin
5		1		-Bearing
6	KA70501061	1	1	— Grease nipple
7	P2H400190a	1	1	Shaft

The mark indicates the range of the set or the complete unit.

.PARTS LIST EHW-60, EHW-120 AIR HOIST

Ref. No.	Part No.	Quantity		Description	Ref. No.	Part No.	Quantity		Description
		EHW-60	EHW-120				EHW-60	EHW-120	
-	LHP000073	1	1	Casing set	60	LHP000149	1	1	Washerset
1	P2H100019d	1	1	-Casing	61	KA00910516	10	10	Cap screw
2	P2H300141a	1	1	-63T internal gear	62	KA00910525	3	3	Cap screw
3	KA42410412	1	1	-Spring pin	63	P2H400136	1	1	Cap screw
4	KA42419812	1	1	-Spring pin	-	LHP000185	1	1	Cylinder set
5	-	1	1	-Meta!	64	-	1	1	-Cylinder
6	KA70501061	1	1	-Grease nipple	3	KA42410412	1	1	-Spring pin
7	P2H400190a	1	1	Shaft	65	P2H400290c	1	1	Key
• 8	P2H400474	1	1	Wave washer	66	P2H300168	1	1	Rotor
9	P2H300139	1	1	Index wheel	• -	LHP000352	1	1	Vane set
10	P2H400191	1	1	Brake lining	67	-	7	7	-Vane
11	P2H400192	1	1	Washer	• 68	KA50200850	1	1	0-ring
• 12	KA32110820	1	1	Conical spring washer	69	LHP000075	1	1	End plate
13	KA21310800	2	2	Hex. nut	-	LHP000996	1	-	Valve body compl.
-	LHP000175	1	1	Valve body assembly	-	LHP000997	-	1	Valve body compl.
14	P2H300143a	1	1	-Valve body	-	LHP001029	1	-	-Valve body set
15	P2H400254	1	1	-Spring	-	LHP001030	-	1	-Valve body set
16	P2H400199a	1	1	-Valve	70	P2H200191	1	1	--Valve body
• 17	KA50200040	1	1	-0-ring	115A	P2H301031	1	-	--Piate
• 18	KA50200080	3	3	-0-ring	115B	P2H301032	-	1	--Piate
• 19	P2H400205	1	1	-Valve seat					
• 20	KA50200120	1	1	-0-ring	71	P2H300169	1	1	-Piug
21	P2H400203	1	1	-Liner	72	P2H400291	1	1	-Valve cone
22	KA43200408	2	2	-Parallel pin	• 73	KA50200090	1	1	-0-ring
23	KA01310525	1	1	Countersunk head cap screw	74	P2H400292a	1	1	-Adapter
• 24	KA60103010	2	2	Ball bearing	75	P2H400293	2	2	-Spring
25A	P2H200084	1	-	Planet shaft	76	P2H300170	2	2	-Spool
25B	P2H200060a	-	1	Planet shaft	• 77	KA50100080	6	6	-0-ring
-	LHP000177	1	-	Gear wheel set	78	P2H401220	2	2	-Spacer
-	LHP000176	-	1	Gear wheel set	• 110	P2H400471	2	2	-Mini Y-packing
26	-	2	3	-Gearwheel	• 73	KA50200090	1	1	0-ring
• 27	P2H400041	4	6	-Needle bearing	79	P2H400295	1	1	Nipple
28	P2H400204a	2	3	Pin	80	KA80111700	2	2	Elbow
29	KA40110035	1	1	Retaining ring	81	P2H400267a	4	4	Elbow
30	P2H300149a	1	1	Shaft	-	LHP000850	1	1	Handle compl.
31	KA60102030	1	1	Ball bearing	82	P2H100059	1	1	-Handle
32	P2H300163a	1	1	Brake wheel	83	LHP000145	1	1	-Push button set
33	P2H400265	1	1	Spacer	84	KA42410325	4	4	-Spring pin
34	P2H300265	2	2	Coned disc spring	85	P2H400296	1	1	-Silencer
35	P2H400266a	1	1	Spacer	86	P2H400297b	1	1	-Support
-	LHP000179		1	Drumset	87	P2H400298	1	1	-Collar
-	LHP000062	-	1	Drumset	88	KA42410206	2	2	-Spring pin
36	P2H200061c	1	1	-Drum	89	P2H400299b	2	2	Pin
37A	P2H300248a	1	-	-59T internal gear	90	P2H400300a	1	1	Washer
37B	P2H300165a	-	1	-60T internal gear	91	KA63100304	1	1	Steel ball
3	KA42410412	1	1	-Spring pin	92	KA16510814	1	1	Setscrew
4	KA42419812	1	1	-Spring pin	• 93	LHP000150	1	1	Wire guide set
38	P2H400268a	1	1	Pin	-	LHP000192	1	1	Hook holder compl.
-	LHP000181	1	1	Wire rope compl.	97	-	2	2	-Hook holder
• 39	LHP000064a	1	1	-Wire rope	101	KA20110400	4	4	-Hex. nut
94	KA16410508	2	2	-Set screw	109	KA00910412	4	4	-Cap screw
95	LHP000068	1	1	-Butter spring	-	LHP000167	1	1	Hookcompl.
96	LHP000151a	1	1	-Stopper	98	-	1	1	-Hook
40	P2H200062c	1	1	Drum	-	LHP000184	1	1	-Hook latch set
41	KA00910512	7	7	Cap screw	57	-	1	1	--Hook latch
42	P2H100022c	1	1	Casing	58	-	1	1	--Spring
-	LHP000183	1	1	End plate set	59	-	1	1	--Rivet
43	-	1	1	-End plate	99	P2H400310	1	1	Nipple Hex.
44	-	1	1	-Bearing	100	KA20712000	2	2	nut Street
• 45	KA60103011	2	2	Ball bearing	102	KA80211700	1	1	elbow
46	KA63100301	2	2	Steel ball	103	LHP000154	1	1	Coil hose compl.
47	P2H400274	1	1	Set plate	103-1	-	1	1	-Coil hose
48	P2H300166b	1	1	Brake cylinder	103-2	-	2	2	-Connector
• 49	P2H400469	4	4	0-ring	104	P2H400467	1	1	Nylontube (blue)
• 50	P2H400275	3	3	Spring	105	P2H400466	1	1	Nylontube (red)
• 51	LHP000070	1	1	Brake cone	106A	P2H300256a	1	-	Name plate
52	P2H400276	1	1	Brake piston	106B	P2H300250a	-	1	Name plate
• 53	P2H400470	1	1	0-ring	107	KA14549803	4	4	Drivescrew
• 54	KA40110020	1	1	Retaining ring	108	P2H400177	4	4	Cap screw
55	P2H400277	3	3	Cap screw	111	KA16410518	1	1	Setscrew
-	LHP000165a	1	1	Hookcompl.	112	KA25520502	1	1	U-nut
56	-	1	1	-Hook	113	P2H300488a	1	1	Caution plate
-	LHP001674	1	1	-Hook latch set	114	P2H400465a	2	2	Convex bell
57	-	1	1	--Hook latch					
58	-	1	1	--Spring					
59	-	1	1	--Rivet					

We recommend that you stock parts indicated by a bullet (•).

Parts without a part number cannot be supplied individually.

When ordering spare parts, specify the part number (not the reference number), description and model name of the hoist.

• EHW-120-2 (Different Part)

Ref. No.	Part No.	Quantity		Description
		EHW-120	2	
—	LHP000174	1		Casing set
1	P2H100019d	1		-Casing
2	P2H300244a	1		-65T internal gear
3	KA42410412	1		-Spring pin
4	KA42419812	1		-Spring pin
5	—	1		-Metal
6	KA70501061	1		-Grease nipple
25	P2H200083a	1		Planet shaft
—	LHP000178	1		Gear wheel set
26	—	3		-Gearwheel
• 27	P2H400041	6		-Needle bearing
30	P2H300247a	1		Shaft
—	LHP000180	1		Drum Set
36	P2H200061c	1		-Drum
37	P2H300245a	1		-62T internal gear
3	KA42410412	1		-Spring pin
4	KA42419812	1		-Spring pin
106	P2H300251a	1		Name plate

• EHW-60-3,
EHW -1 20-3 (Different Part)

Ref. No.	Part No.	Quantity		Description
		EHW-60-EHW-120-1		
—	LHP000182	1	1	Wire rope c mpl.
• 39	LHP000168	1	1	-Wire rope
94	KA16410508	2	2	-Set screw
95	LHP000068	1	1	-Buffer spring
96	LHP000170	1	1	-Stopper
40	LHP001328	1	1	Drum
40-1	—	1	1	-Drum
40-2	P2H401823	1	1	-Seal
106	P2H300257	1	—	Name plate
106	P2H300252	—	1	Name plate

We recommend that you stock parts indicated by a bullet (•).

Parts without a part number cannot be supplied individually.

When ordering spare parts, specify the part number (not the reference number), description and model name of the hoist.

■ EHW-60
 ■ EHW-120

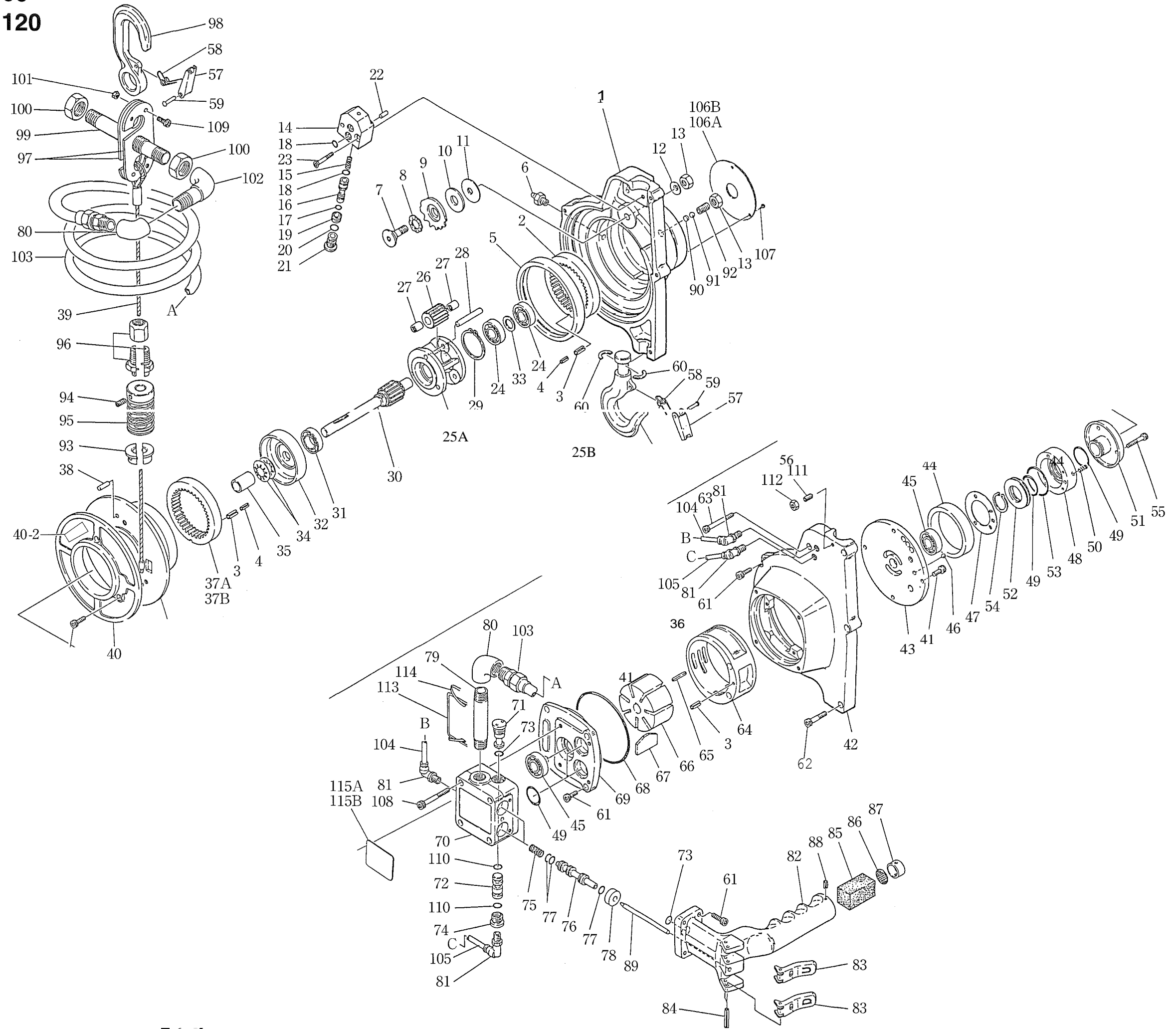

.PARTS LIST EHW-60R, EHW-120R AIR HOIST

Ref. No.	Part No.	Quantity		Description	Ref. No.	Part No.	Quantity		Description
		EHW-60R	EHW-120R				EHW-60R	EHW-120R	
-	LHP000073	1	1	Casing set	-	LHP000185	1	1	Cylinder set
1	P2H100019d	1	1	-Casing	64	-	1	1	-Cylinder
2	P2H300141a	1	1	-63T internal gear	3	KA42410412	1	1	-Spring pin
3	KA42410412	1	1	-Spring pin	65	P2H400290c	1	1	Key
4	KA42419812	1	1	-Spring pin	66	P2H300168	1	1	Rotor
5	-	1	1	-Metal	e	LHP000352	1	1	Vane set
6	KA70501061	1	1	-Grease nipple	67	-	7	7	-Vane
7	P2H400190a	1	1	Shaft	68	KA50200850	1	1	0-ring LHP000075
• 8	P2H400474	1	1	Wave washer	69	-	1	1	End plate
9	P2H300139	1	1	Index wheel	-	LHP000990	1	-	Valve body compl.
10	P2H400191	1	1	Brake lining	-	LHP000991	-	1	Valve body compl.
11	P2H400192	1	1	Washer	-	LHP001031	1	-	-Valve body set
• 12	KA32110820	1	1	Conical spring washer	-	LHP001032	-	1	-Valve body set
13	KA21310800	2	2	Hex. nut	70	P2H200192	1	1	--Valve body
	LHP000175	1	1	Valve body assembly	110A	P2H301031	1	-	--Plate
14	P2H300143a	1	1	-Valve body	110B	P2H301032	-	1	--Plate
15	P2H400254	1	1	-Spring					
16	P2H400199a	1	1	-Valve	71	P2H300169	1	1	-Piug
e 17	KA50200040	1	1	-0-ring	72	P2H400291	1	1	-Valve cone
• 18	KA50200080	3	3	-0-ring	• 73	KA50200090	1	1	-0-ring
• 19	P2H400205	1	1	-Valve seat	74	P2H400292a	1	1	-Adapter
- 20	KA50200120	1	1	-0-ring	• 105	P2H400471	2	2	-Mini Y-packing
21	P2H400203	1	1	-Liner	75	P2H400267a	4	4	Elbow
22	KA43200408	2	2	-Parallel pin	76	KA80211700	1	1	Street elbow
23	KA01310525	1	1	Countersunk head cap screw	77	LHP000069	3	3	Hose compl.
• 24	KA60103010	2	2	Ball bearing	77-1	-	3	3	-Nipple
25A	P2H200084	1	-	Planet shaft	77-2	-	3	3	-Hose
25B	P2H200060a	1	1	Planet shaft	77-3	-	3	3	-Lock tube
-	LHP000177	1	-	Gear wheel set	-	LHP000852b	1	1	Handle assembly
-	LHP000176	-	1	Gear wheel set	77-4	P1R400323	3	3	-Nipple
26	-	2	3	-Gearwheel	-	LHP000992a	1	1	-Valve body compl.
• 27	P2H400041	4	6	-Needle bearing	78	P2H200193a	1	1	--Valve body
28	P2H400204a	2	3	Pin	79	P2H400293	2	2	--Spring
29	KA40110035	1	1	Retaining ring	80	P2H300170	2	2	--Spool
30	P2H300149a	1	1	Shaft	iii 81	KA50100080	6	6	--0-ring
31	KA60102030	1	1	Ball bearing	82	P2H401220	2	2	--Spacer
32	P2H300163a	1	1	Brake wheel	-	LHP000851	1	1	-Handle compl.
33	P2H400265	1	1	Spacer	83	P2H100058	1	1	--Handle
34	P2H300265	2	2	Coned disc spring	84	LHP000145	1	1	-- Push button set
35	P2H400266a	1	1	Spacer	85	KA42410325	4	4	--Spring pin
-	LHP000179	1	-	Drumset	86	P2H400296	1	1	--Silencer
-	LHP000062	-	1	Drumset	87	P2H400297b	1	1	--Support
36	P2H200061c	1	1	-Drum	88	P2H400298	1	1	--Collar
37A	P2H300248a	1	-	-59T internal gear	89	KA42410206	2	2	--Spring pin
37B	P2H300165a	-	1	-BOT internal gear	• 73	KA50200090	1	1	-0-ring
3	KA42410412	1	1	-Spring pin	90	P2H400307b	2	2	-Pin
4	KA42419812	1	1	-Spring pin	91	P2H400957	4	4	-Gap screw
38	P2H400268a	1	1	Pin	92	P2H400300a	1	1	Washer
-	LHP000181	1	1	Wire rope compl.	93	KA63100304	1	1	Steel ball
• 39	LHP000064a	1	1	-Wire rope	94	KA16510814	1	1	Setscrew
96	KA16410508	2	2	-Set screw	• 95	LHP000150	1	1	Wire guide set
97	LHP000068	1	1	-Buffer spring	-	LHP000844	1	1	Swivel hook assembly
98	LHP000151a	1	1	-Stopper	-	LHP000843	1	1	-Hook compl.
40	P2H200062c	1	1	Drum	99-1	-	1	1	--Hook
41	KA00910512	7	7	Cap screw	-	LHP001674	1	1	--Hook latch set
42	P2H100022c	1	1	Casing	57	-	1	1	--- Hook latch
-	LHP000183	1	1	End plate set	58	-	1	1	---Spring
43	-	1	1	-End plate	59	-	1	1	---Rivet
44	-	1	1	-Bearing	99-4	-	1	1	--Nut
• 45	KA60103011	2	2	Ball bearing	99-5	KA42419820	1	1	--Spring pin
46	KA63100301	2	2	Steel ball	99-2	P2H401216	1	1	-Hook holder
47	P2H400274	1	1	Set plate	• 99-3	KA60401000	1	1	-Thrust bearing
48	P2H300166b	1	1	Brake cylinder	99-6	P2H300665a	1	1	-Hook holder
ii 49	P2H400469	4	4	0-ring	99-7	P2H401218	1	1	-Pin
• 50	P2H400275	3	3	Spring	99-8	KA16510506	1	1	-Set screw
• 51	LHP000070	1	1	Brake cone	99-9	KA32410520	1	1	-CD-washer
52	P2H400276	1	1	Brake piston	99-10	KA00910512	1	1	-Gap screw
- 53	P2H400470	1	1	0-ring	100	P2H400467	1	1	Nylontube (blue)
- 54	KA40110020	1	1	Retaining ring	101	P2H400468	1	1	Nylon tube (red)
55	P2H400277	3	3	Cap screw	102A	P2H300258a	1	-	Name plate
-	LHP000165a	1	1	Hookcompl.	102B	P2H300253a	-	1	Name plate
56	-	1	1	-Hook	103	KA14549803	4	4	Drivescrew
-	LHP001674	1	1	-Hook latch set	104	KA86100120	3	3	Hoseclip
57	-	1	1	---Hook latch	106	P2H400465a	4	4	Convex belt
58	-	1	1	--Spring	107	KA16410518	1	1	Setscrew
59	-	1	1	--Rivet	108	KA25520502	1	1	U-nut
60	LHP000149	1	1	Washerset	109	P2H300488a	1	1	Caution plate
61	KA00910516	6	6	Cap screw					
62	KA00910525	3	3	Cap screw					
63	P2H400136	5	5	Cap screw					

We recommend that you stock parts indicated by a bullet (e).

Parts without a part number cannot be supplied individually.

When ordering spare parts, specify the part number (not the reference number), description and model name of the hoist.

● EHW-120R-2 (Different Part)

Ref. No.	Part No.	Quantity EHW-120 R-2	Description
—	LHP000174	1	Casing set
1	P2H100019d	1	-Casing
2	P2H300244a	1	-65T internal gear
3	KA42410412	1	-Spring pin
4	KA42419812	1	-Spring pin
5	—	1	-Metal
6	KA70501061	1	-Grease nipple
25	P2H200083a	1	Planet shaft
—	LHP000178	1	Gear wheel set
26	—	3	-Gear wheel
● 27	P2H400041	6	-Needle bearing
30	P2H300247a	1	Shaft
—	LHP000180	1	Drumset
36	P2H200061c	1	-Drum
37	P2H300245a	1	-62T internal gear
3	KA42410412	1	-Spring pin
4	KA42419812	1	-Spring pin
102	P2H300254a	1	Name plate

● EHW-60R-3,
EHW-120R-3 (Different Part)

Ref. No.	Part No.	Quantity EHUR-JEHW-mR-J	Description
—	LHP000182	1 1	Wire rope compl.
● 39	LHP000168	1 1	-Wire rope
96	KA16410508	2 2	-Set screw
97	LHP000068	1 1	-Buffer spring
98	LHP000170	1 1	-Stopper
40	LHP001328	1 1	Drum
40-1	—	1 1	-Drum
40-2	P2H401823	1 1	-Seal
102	P2H300259	1	Name plate
102	P2H300255	— 1	Name plate

We recommend that you stock parts indicated by a bullet (●).

Parts without a part number cannot be supplied individually.

When ordering spare parts, specify the part number (not the reference number), description and model name of the hoist

ИЕHW-60R
ИЕHW-120R

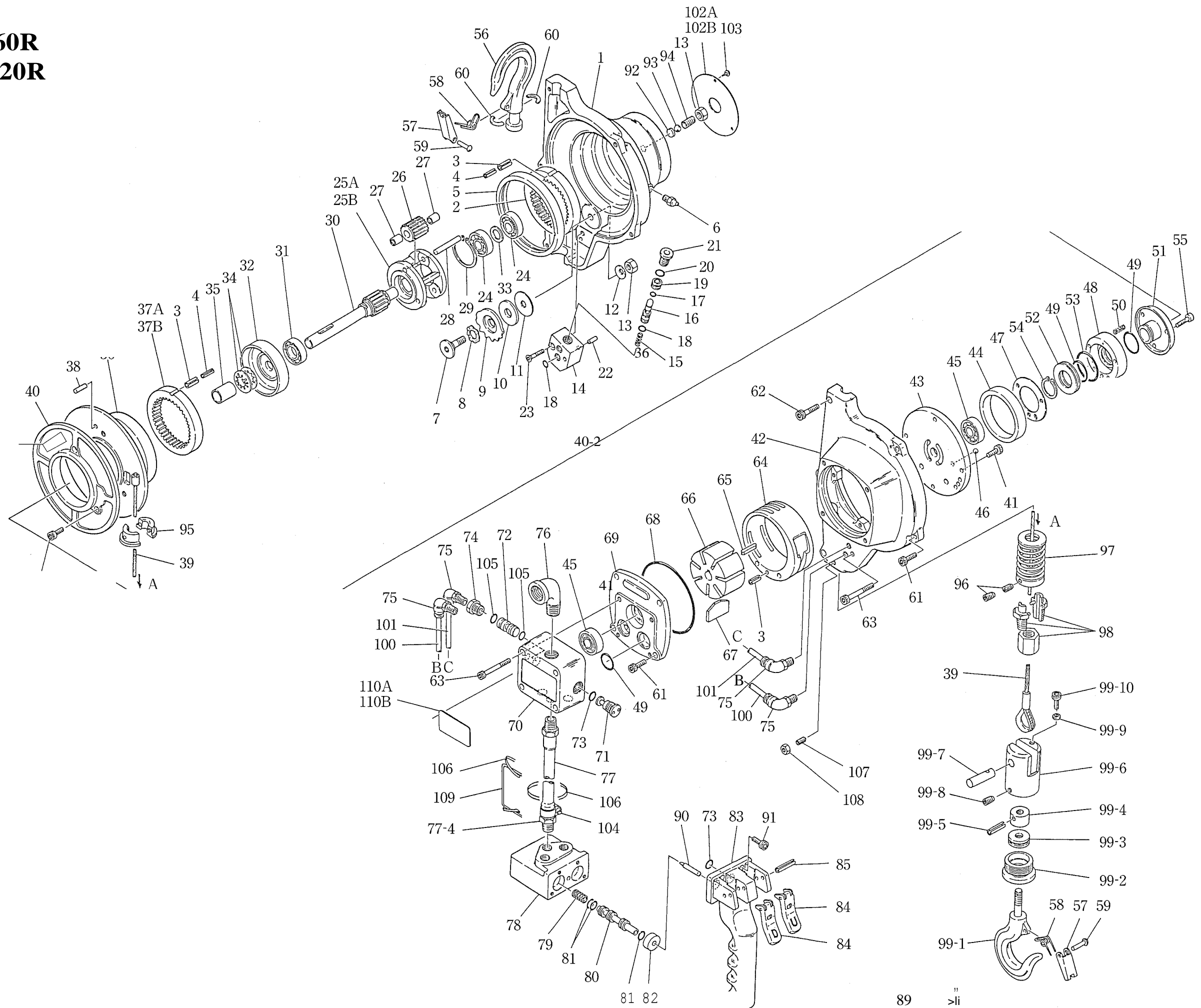

89 >li

86

87-----@

